



**1,6mm Circular Contact System**

**1. INTRODUCTION**

This Specification covers the requirements for application of 1,6mm Circular Contact System.

The various contact types are listed in Tables 1 & 2, sorted by their wire ranges and crimping data.

The instructions are primarily intended for automatic or semi-automatic application of all versions (for both wires and single wire sealing), but may also be applied, if agreed and developed, to hand tools.

These contacts are suitable for 0,22÷2,5sqmm wire, with and without single wire seals.

The indications on the pictures are valid for both receptacle and tab contacts.

**2. REFERENCED DOCUMENTS**

**2.1 CUSTOMER DRAWINGS**

There are Customer Drawings C-1418069 and C-1418070 showing the dimensions and materials for each Part Number.

In case of conflict between this document and the Customer Drawing, the Customer Drawing takes the precedence.

**2.2 PRODUCT SPECIFICATION**

The Product Specification 108-20260 describes the performances of these contacts, together with the electrical and mechanical characteristics.

**2.3 APPLICATION SPECIFICATION**

The general guidelines laid down on Application Specification 114-18022, former Thomas & Betts Crimping Specification AC/T/18/95 and FORD Specification S-89FG 14488 AA have also been taken for reference.

**2.4 NATIONAL / INTERNATIONAL STANDARDS**

DIN 72551 T5 /T6      Unscreened low tension cables (FLR)

DIN ISO 6722 T1/T2/T3      Unscreened low tension cables (FLK)

<b>A</b>	<b>FIRST ISSUE</b>		M.GHISOLFI	31/03/2006		R.MARTINI	03/04/2006
rev letter	rev. record	DR	DR	Date	CHK	CHK	Date
DR.		DATE	APVD				DATE
M. Ghisolfi		04/03/2006	A. Genta				26/04/2006

This specification is a controlled document.

This AMP controlled document is subject to change. For latest revision call AMP Italia s.p.a., Collegno (TO), Italy.

\* Trademark

**3. DESCRIPTION**

The following information contains nomenclature, crimping conditions, crimp data for mini-applicators, insertion of wire seals on cables and checks.

**3.1 NOMENCLATURE**

The terms shown in the pictures here below are used in this Specification:

**3.1.1 CONTACTS FOR WIRES**

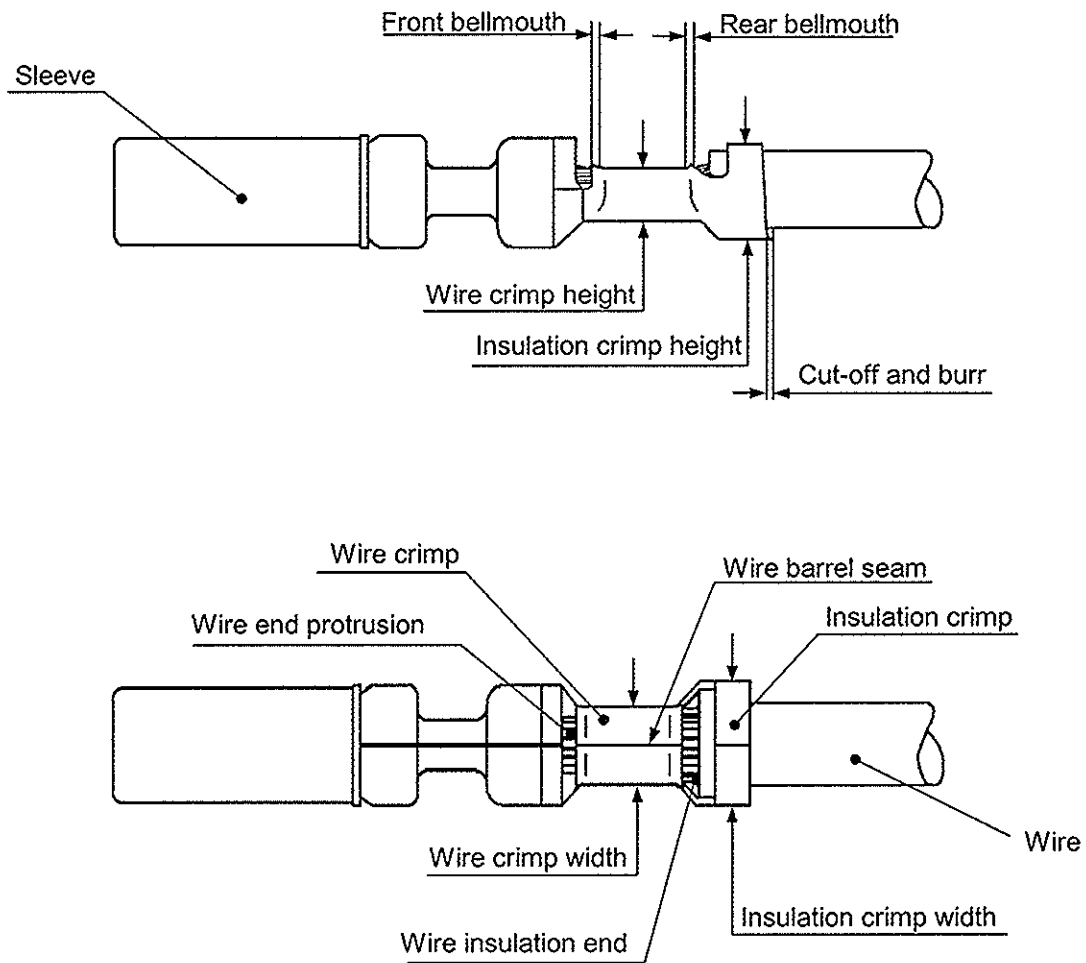

3.1.2 CONTACTS FOR SINGLE WIRE SEALS

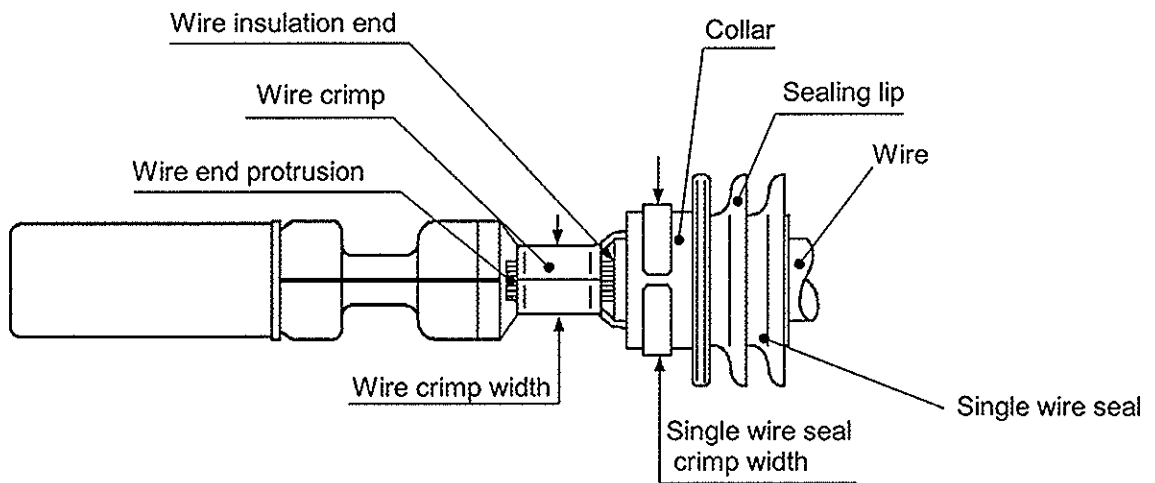
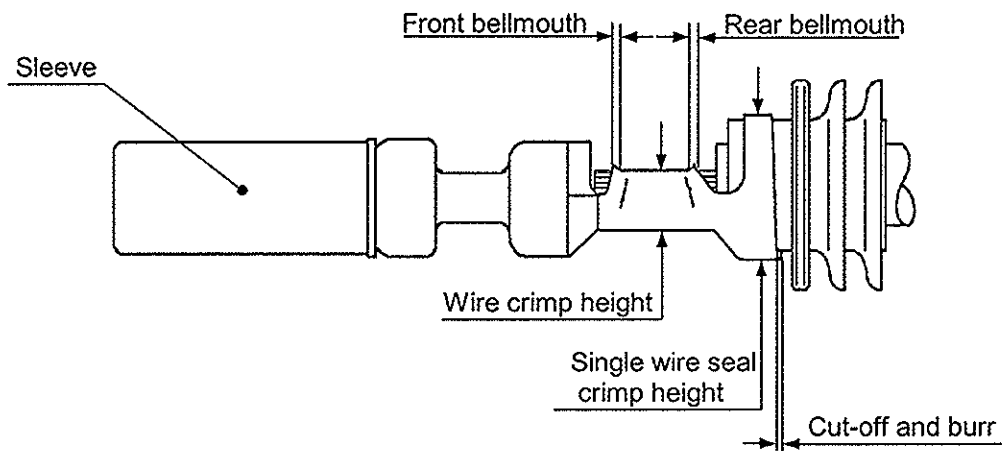

#### **4. REQUIREMENTS / CRIMP CONDITIONS**

##### **4.1 WIRES / PREPARATION**

The contacts and single wire seals are designed for FLR conductors acc. to DIN 72551 Part 5 and Part 6 or FLK conductors acc. to DIN ISO 6722 Parts 1-3.  
Other wires require the approval of the Engineering Department.

Single termination is preferred. Double crimping is possible within the wire range with FLR conductors.

Each wire must be stripped to the lengths shown in Tables 1 and 2.  
Take care that the individual strands of the cut wire are not bent or cut off.  
The wire insulation must be clean and free of any contamination, must present a smooth circular surface without damages or grooves.  
For single wire sealing, particular care must be taken so that the wire insulation in the sealing area is not damaged, compressed or deformed.

##### **4.2 CUT-OFF AND BURR**

The maximum length of the cut-off is 0,5mm.  
Any burrs at the shearing point may not exceed 0,08mm.

##### **4.3 WIRE CRIMP**

###### **4.3.1 Wire position**

After crimping, the wire end protrusion must extend  $0,6 \pm 0,4$ mm beyond the front end of the wire crimp.

###### **4.3.2 Crimping data / conditions**

The shape, height and width of the crimp, together with the wire range, are shown in Tables 1 & 2.  
Wire barrel seam must be neatly closed.

###### **4.3.3 Crimp bellmouth**

The size of the rear bellmouth depends on the wire range:

$0,35 \div 0,5\text{mm}^2$ :  $0,25 \pm 0,15\text{mm}$   
 $0,50 \div 2,5\text{mm}^2$   $0,4 \pm 0,2\text{mm}$

A front bellmouth is permissible.

#### 4.4 INSULATION CRIMP

##### 4.4.1 Position of the end of the insulation

The wire insulation end must be visible in the transition between the wire crimp and the insulation crimp zones.

After crimping, no part of the wire insulation or rubber of single wire seal must result crimped in the wire crimp zone.

In case of contacts for single wire sealings, the end of the insulation must be at the same level of the front edge of the single wire seal or may protrude up to 0,5mm max. from this edge:

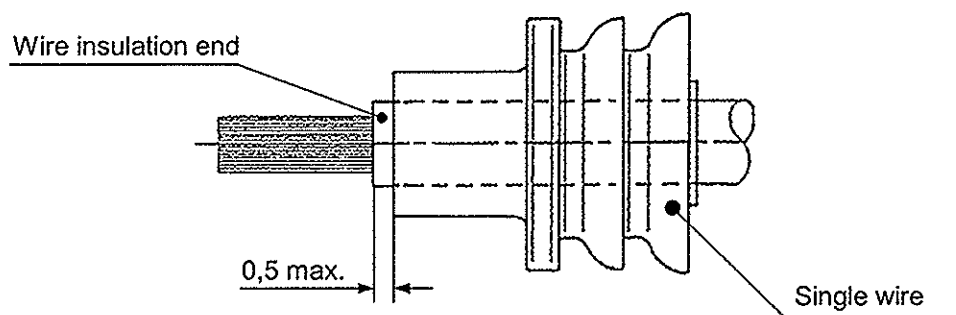

##### 4.4.2 Crimping data

The shape, height and width of the crimp, together with the insulation diameter and part number of single wire seals, where appropriate, are shown in Tables 1 & 2.

##### 4.4.3 Insertion / Position of the single wire seal

The insertion of the single wire seal shall be done straightly and evenly.

After the insertion of the wire seal, the end of the wire shall be straight, without bend and untidiness.

If flanges are in tilt condition, the plug must be corrected so that the flanges are perpendicular to contact center line. The flanges shall be free from cuts and damages: any seal having such a defect must be discarded and replaced with a new part.

After crimping, the rubber seal must protrude from the insulation crimp without any damage.

##### 4.4.4 Double wire crimping

In case of double wire crimping, in presence of wires of different wire sizes and placed on top of each other, the smaller cable should be placed in the bottom of the barrel.

**5. REQUIREMENTS FOR THE CRIMPED TERMINALS**

**5.1 Damage**

The contact must not show evidence of damage or deformation as a result of crimping process: it must fit easily into the cavities.

**5.2 Terminal bend (Sideways)**

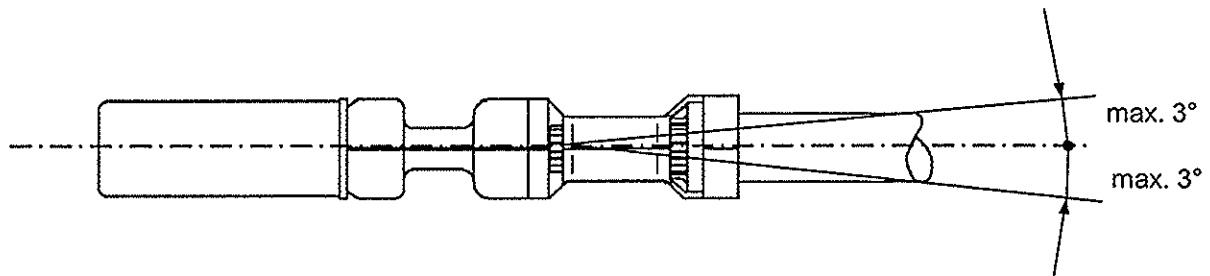

The bend of the terminal within the crimp area must not exceed 3° to each side.

**5.3 Terminal bend (Up and Down)**

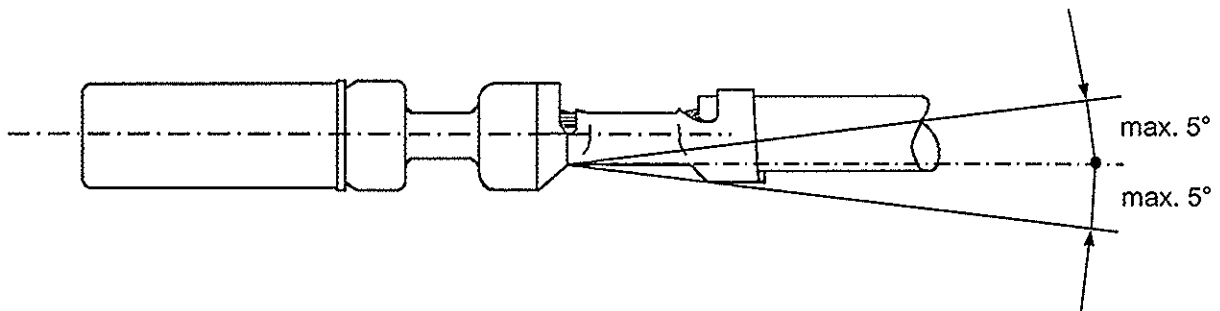

The bend of the terminal within the crimp area must not exceed 5° upwards or downwards.

6. SHAPES / NOMENCLATURE

6.1 Crimp with single wire seals:

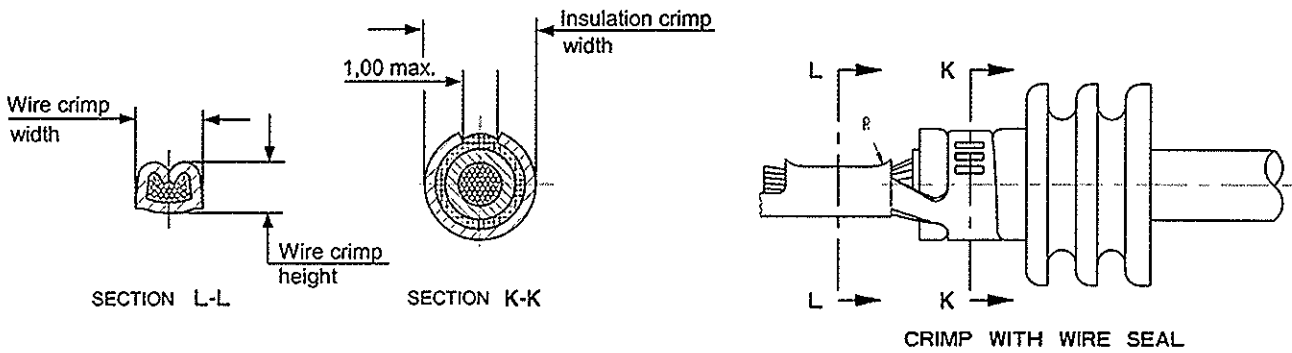

Picture 1

6.2 Crimp without single wire seals:

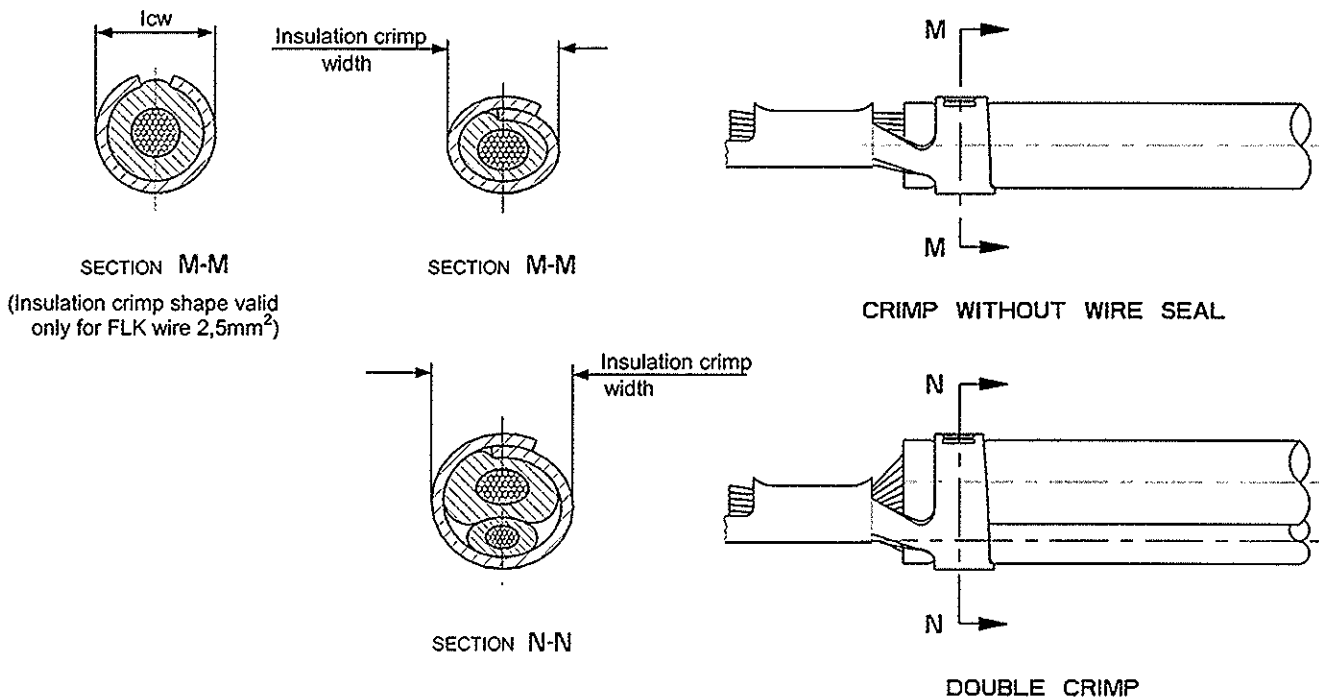

Picture 2

Table 1

CRIMPING DATA FOR 1,6mm CIRCULAR CONTACT SYSTEM TERMINALS WITHOUT SINGLE WIRE SEALS											
Part Number Socket Contacts / Pin contacts	Wire-size (mm <sup>2</sup> )	Crimp Combination (mm <sup>2</sup> )	Insulated conductor type	Insulation diameter (mm)	Strip length (mm)	Wire crimp			Insulation Crimp		Applicator
						Width (mm)	Height (mm) ±0,05	Shape	Width (mm) ±0,2	Shape	
0-1437709-3 0-1437709-9 1-1437709-4 / 0-1437709-6 1-1437709-1	0,22 - 0,35	0,22 0,30 0,35	FLR	1,15 - 1,4	3,9 - 4,7	1,57 <sup>+0,15</sup> <sub>0</sub>	0,96 ± 0,03 1,00 ± 0,03 1,03 ± 0,03	F (see Picture 1 on page 7)	2,29	Overlapped (see Picture 2 on page 7)	X-1426299-X  X-1528589-X (fine adjust version)
0-1437709-2 1-1437709-0 1-1437709-5 2-1437709-8 / 0-1437709-7 1-1437709-2	0,5 - 1,0	0,5 0,75 1,0  0,35 + 0,35 0,5 + 0,35 0,5 + 0,5	FLR	1,4 - 2,1		2,03 <sup>+0,2</sup> <sub>0</sub>	1,15 1,24 1,33  1,21 1,27 1,33		2,79		X-1426585-X  X-1528590-X (fine adjust version)
0-1437709-2 1-1437709-0 1-1437709-5 2-1437709-8 / 0-1437709-7 1-1437709-2	0,5 - 1,0	0,5 0,75 1,0	FLK	2,0 - 2,7		2,03 <sup>+0,2</sup> <sub>0</sub>	1,15 1,24 1,33		2,79		
0-1437709-1 1-1437709-6 1-1437709-7 / 1-1437709-3	1,25 - 2,5	1,5 2,0 2,5  0,75 + 0,5 0,75 + 0,75 1,0 + 0,5 1,0 + 0,75 1,0 + 1,0 1,5 + 0,5	FLR	2,2 - 3,0	4,0 - 4,8	2,54 <sup>+0,25</sup> <sub>0</sub>	1,50 1,65 1,80  1,48 ± 0,03 1,50 1,50 1,55 1,65 1,65	F (see Picture 1 on page 7)	3,81	Overlapped (see Picture 2 on page 7)	X-1426586-X  X-1528591-X (fine adjust version)
0-1437709-1 1-1437709-6 1-1437709-7 / 1-1437709-3	1,5 - 2,5	1,5 2,0 2,5	FLK	2,7 - 3,6		2,54 <sup>+0,25</sup> <sub>0</sub>	1,50 1,65 1,80		3,81		See Picture 2 on page 7

NOTE: ALTERNATIVE CRIMP DATA ACCORDING TO FORMER THOMAS & BETTS SPEC. AC/T/18/95 AND ACCORDING TO FORD SPEC. S89FG-14488-AA ARE ALLOWED ON ALREADY EXISTING CRIMPING TOOLINGS.



Table 2

CRIMPING DATA FOR 1,6mm CIRCULAR CONTACT SYSTEM TERMINALS WITH SINGLE WIRE SEALS												
Part Number Socket Contacts / Pin contacts	Wire- size (mm <sup>2</sup> )	Crimp Combination (mm <sup>2</sup> )	Insulated conductor type	Insulation diameter (mm)	Strip length (mm)	Wire crimp			Insulation Crimp		Single Wire Seal	Applicator
						Width (mm)	Height (mm)	Shape	Width (mm)	Shape		
0-1437709-3 0-1437709-9 1-1437709-4 / 0-1437709-6 1-1437709-1	0,22 - 0,35	0,22 0,30 0,35	FLR	1,15 - 1,4	3,9 - 4,7	1,57 <sup>+0,15</sup> <sub>0</sub>	0,96 ± 0,03 1,00 ± 0,03 1,03 ± 0,03	F (see Picture 1 on page 7)	2,54	O (see Picture 1 on page 7)	1-1437713-1	X-1426587-X
0-1437709-2 1-1437709-0 1-1437709-5 2-1437709-8 / 0-1437709-7 1-1437709-2												0,5 0,75 1,0
0-1437709-1 1-1437709-6 1-1437709-7 / 1-1437709-3	1,5 - 2,0	1,5 2,0	FLR	2,2 - 2,8	4,0 - 4,8	2,54 <sup>+0,25</sup> <sub>0</sub>	1,50 1,65	F	3,81	O	1-1437713-3	X-1426314-X X-1528563-X (fine adjust version)

NOTE: ALTERNATIVE CRIMP DATA ACCORDING TO FORMER THOMAS & BETTS SPEC. AC/T/18/95 AND ACCORDING TO FORD SPEC. S89FG-14488-AA ARE ALLOWED ON ALREADY EXISTING CRIMPING TOOLINGS.

单击下面可查看定价，库存，交付和生命周期等信息

[>>TE Connectivity\(泰科\)](#)