

REVISIONS				
P	LTN	DESCRIPTION	DATE	APVD
V		REDRAWN/REVISED PER ECO-17-001757	09NOV2017	GR JO

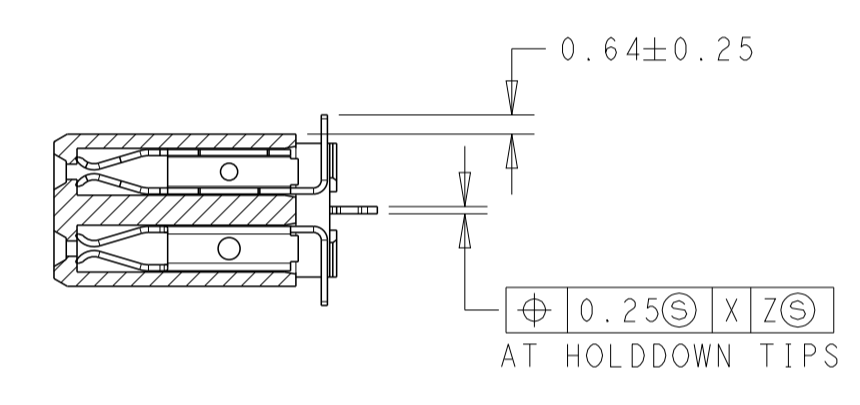

SECTION A-A

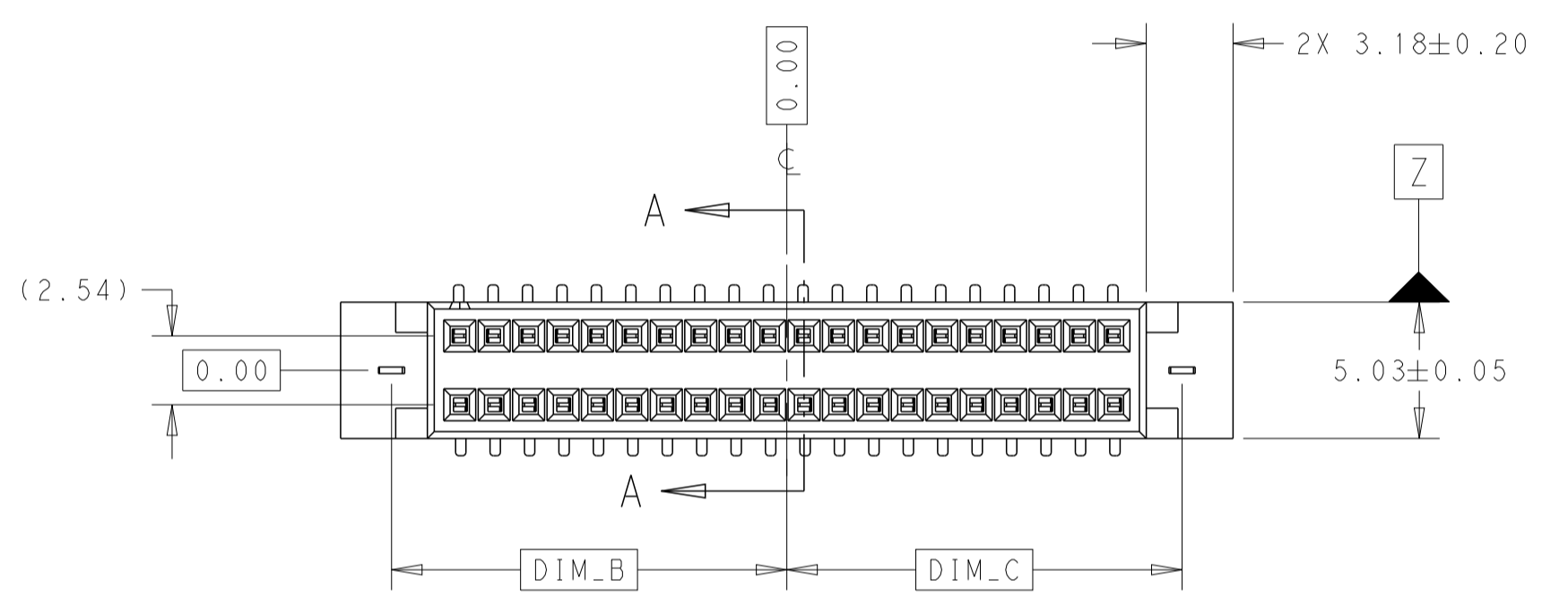
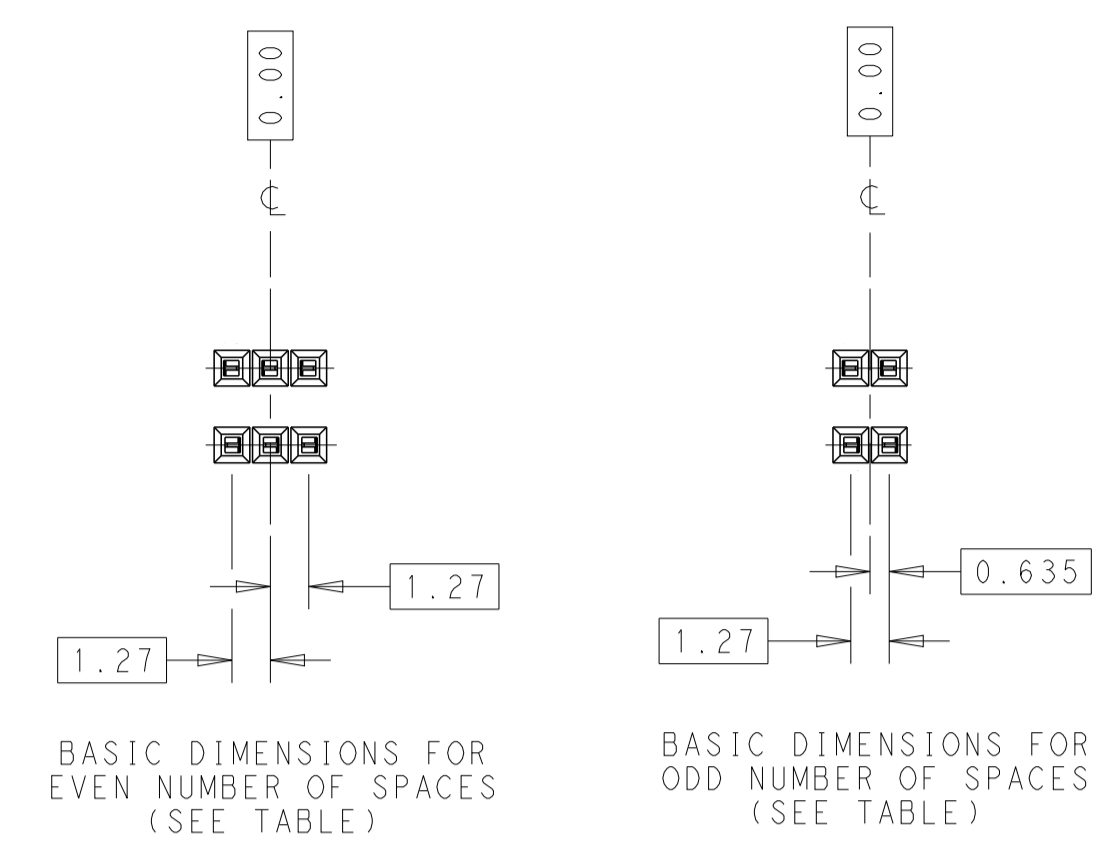
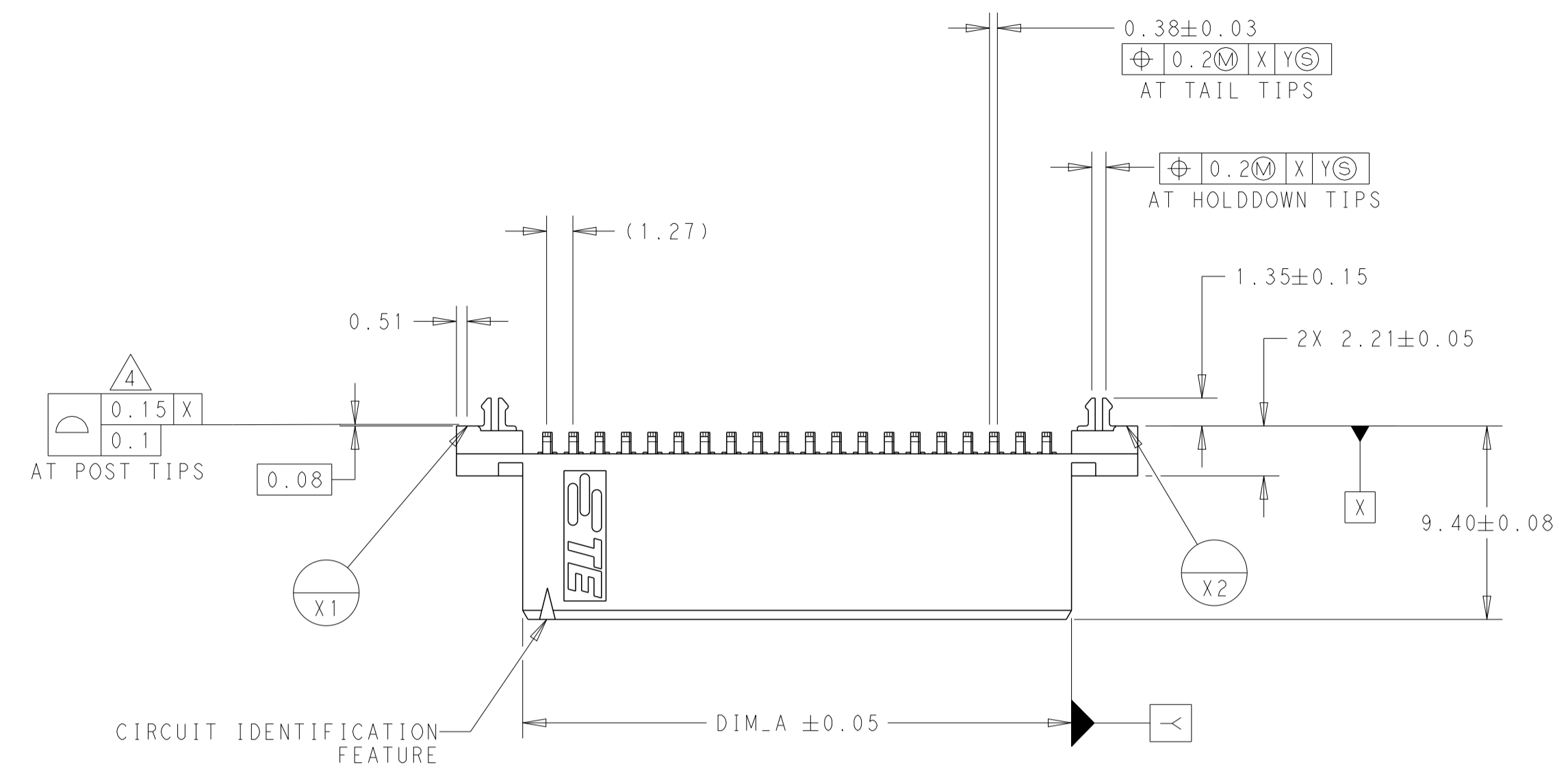
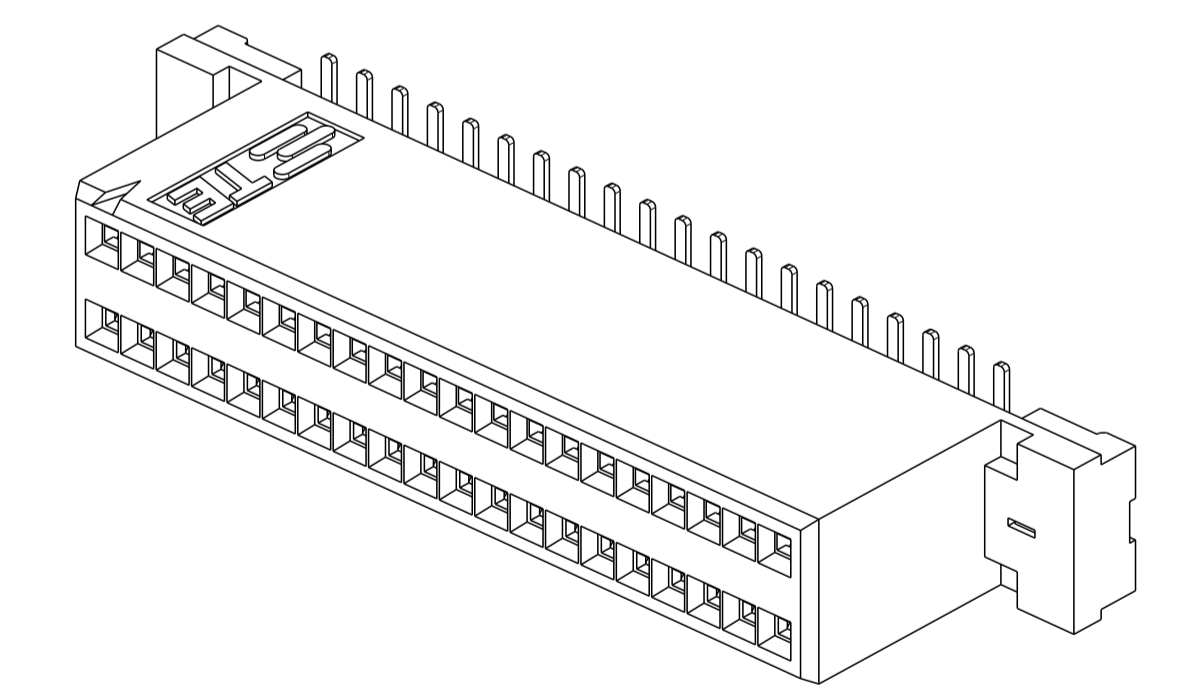
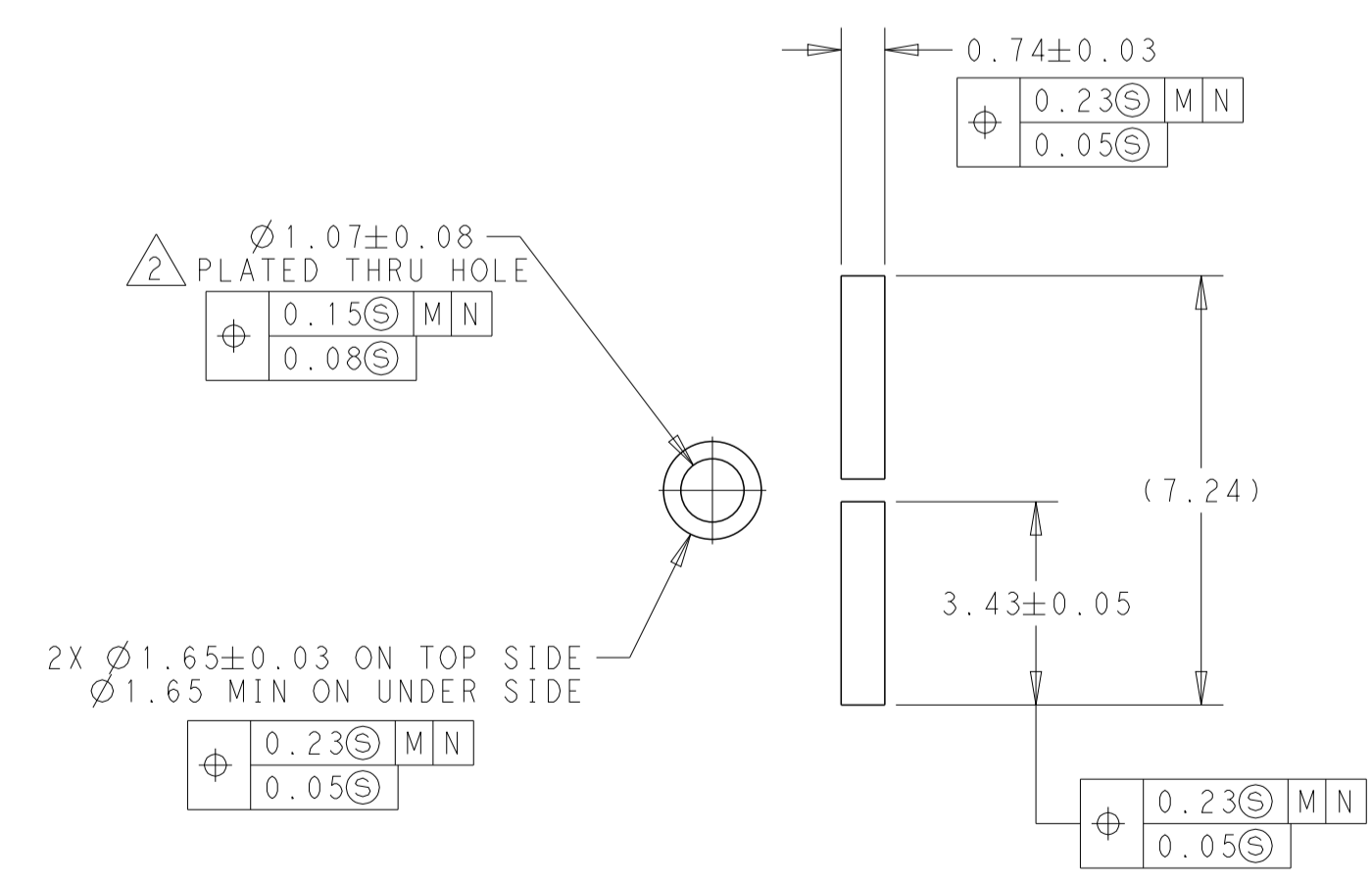
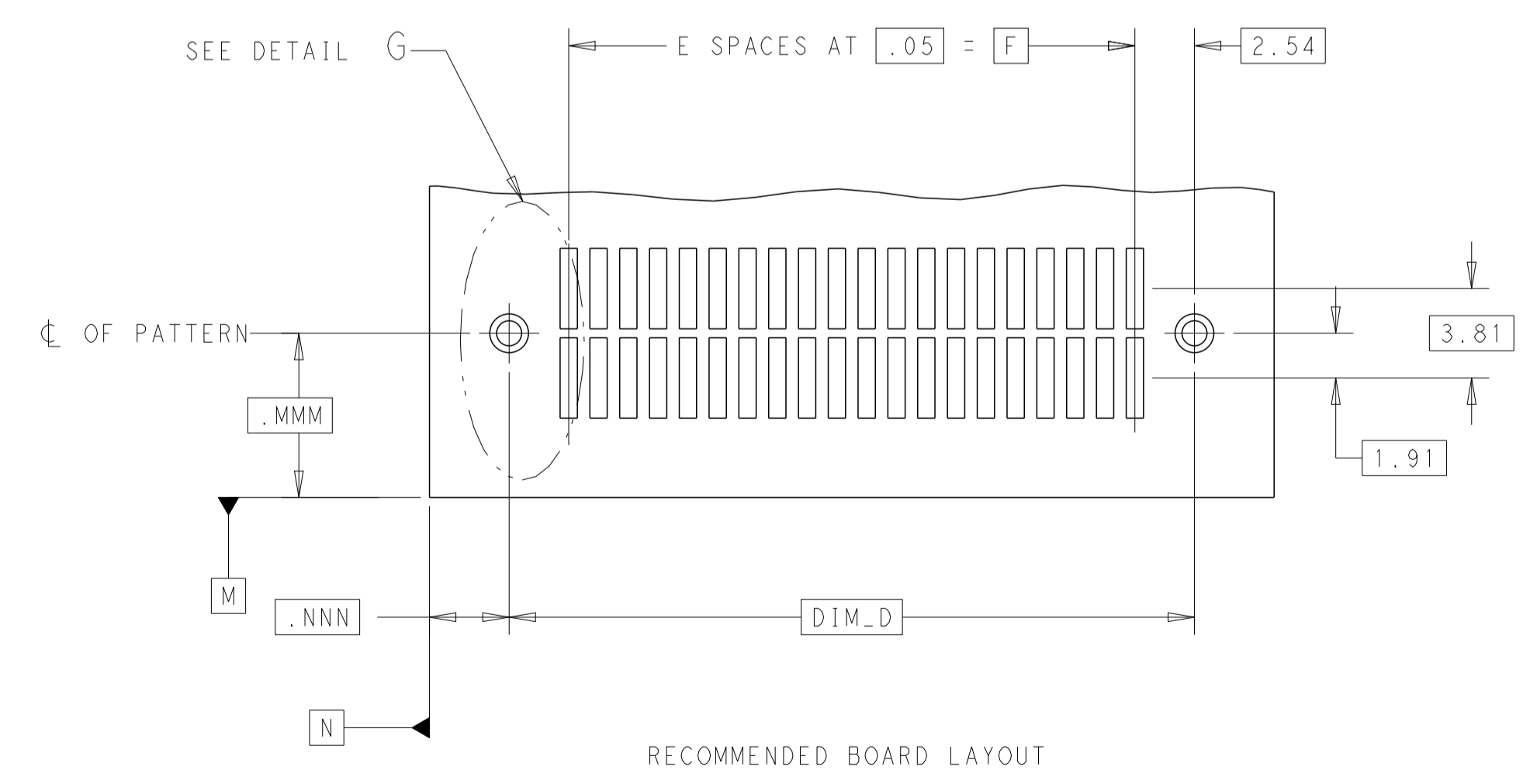

SCALE 5:1

THIS DRAWING IS A CONTROLLED DOCUMENT.		DWN: G. RAMESH 08NOV2017	TE Connectivity
DIMENSIONS:		CHK: J. OLSON 08NOV2017	
mm	TOLERANCES UNLESS OTHERWISE SPECIFIED:	APVD: J. OLSON 08NOV2017	NAME: RECEPTACLE ASSEMBLY, VERTICAL, DOUBLE ROW SURFACE MOUNT, AMPMODU System 50
	0 PLC ±.3	PRODUCT SPEC	SIZE: A1
	1 PLC ±0.3	APPLICATION SPEC	CAGE CODE: -
	2 PLC ±.13	WEIGHT: -	DRAWING NO: C=104550
	3 PLC ±.1	CUSTOMER DRAWING	SCALE: 4:1
	4 PLC ±.1	RESTRICTED TO: -	SHEET 1 OF 2
MATERIAL: 11	ANGLES: ±0.5		REV: V

REVISIONS				
P	LTN	DESCRIPTION	DATE	APPD
-	-	SEE SHEET 1	-	-

- 1 0.76µm GOLD IN LOCALIZED PLATE AREA, 3.81µm TIN-LEAD ON SOLDER TAILS ALL OVER 1.27µm NICKEL.
- 2 USE 1.18 ±0.025 DRILLED HOLE (#56 DRILL) FINISH TO BE TIN-LEAD OVER 0.025 MINIMUM COPPER.
- 3 NOTE DELETED.
- 4 REFER TO NO. OF POSN. IN CHART FOR NUMBER OF SURFACES WHICH ARE COPLANAR.
- 5 NOTE DELETED.
- 6 0.76µm GOLD IN LOCALIZED PLATE AREA, 3.81µm TIN ON SOLDER TAILS ALL OVER 1.27µm NICKEL.
- 7 NOTE DELETED.
- 8 NOTE DELETED.
- 9 FINISH: 0.03µm MIN GOLD ON GOLD PLATED AREA, 3.81µm MATTE IN TIN-LEAD ON TIN PLATED AREA UNDER PLATING: 1.27µm NICKEL ON ENTIRE CONTACT.
- 10 FINISH: 0.03µm MIN GOLD ON GOLD PLATED AREA, 3.81µm MATTE IN TIN ON TIN PLATED AREA UNDER PLATING: 1.27µm NICKEL ON ENTIRE CONTACT.
- 11 MATERIAL: HOUSING:LCP
 COLOR:BLACK
 CONTACT:PHOS BRONZE

10	62.23	49	67.31	33.66	33.66	64.62	100	7-104550-9
	49.53	39	54.61	27.30	27.30	51.92	80	7-104550-8
	36.83	29	41.91	20.96	20.96	39.22	60	7-104550-7
	30.48	24	35.56	17.78	17.78	32.87	50	7-104550-6
	24.13	19	29.21	14.60	14.60	26.52	40	7-104550-5
	17.78	14	22.86	11.43	11.43	20.17	30	7-104550-4
	13.97	44	19.05	9.53	9.53	16.36	24	7-104550-3
	11.43	9	16.51	8.26	8.26	13.82	20	7-104550-2
	5.08	4	10.16	5.08	5.08	7.47	10	7-104550-1
	62.23	49	67.31	33.66	33.66	64.62	100	5-104550-9
49.53	39	54.61	27.30	27.30	51.92	80	5-104550-8	
36.83	29	41.91	20.96	20.96	39.22	60	5-104550-7	
30.48	24	35.56	17.78	17.78	32.87	50	5-104550-6	
24.13	19	29.21	14.60	14.60	26.52	40	5-104550-5	
17.78	14	22.86	11.43	11.43	20.17	30	5-104550-4	
13.97	44	19.05	9.53	9.53	16.36	24	5-104550-3	
11.43	9	16.51	8.26	8.26	13.82	20	5-104550-2	
5.08	4	10.16	5.08	5.08	7.47	10	5-104550-1	
FINISH	DIM_F	E SPACES	DIM_D	DIM_C	DIM_B	DIM_A	NO OF POSN	PART NUMBER

9	62.23	49	67.31	33.66	33.66	64.62	100	2-104550-9
	49.53	39	54.61	27.30	27.30	51.92	80	2-104550-8
	36.83	29	41.91	20.96	20.96	39.22	60	2-104550-7
	30.48	24	35.56	17.78	17.78	32.87	50	2-104550-6
	24.13	19	29.21	14.60	14.60	26.52	40	2-104550-5
	17.78	14	22.86	11.43	11.43	20.17	30	2-104550-4
	13.97	44	19.05	9.53	9.53	16.36	24	2-104550-3
	11.43	9	16.51	8.26	8.26	13.82	20	2-104550-2
	5.08	4	10.16	5.08	5.08	7.47	10	2-104550-1
	62.23	49	67.31	33.66	33.66	64.62	100	104550-9
49.53	39	54.61	27.30	27.30	51.92	80	104550-8	
36.83	29	41.91	20.96	20.96	39.22	60	104550-7	
30.48	24	35.56	17.78	17.78	32.87	50	104550-6	
24.13	19	29.21	14.60	14.60	26.52	40	104550-5	
17.78	14	22.86	11.43	11.43	20.17	30	104550-4	
13.97	44	19.05	9.53	9.53	16.36	24	104550-3	
11.43	9	16.51	8.26	8.26	13.82	20	104550-2	
5.08	4	10.16	5.08	5.08	7.47	10	104550-1	
FINISH	DIM_F	E SPACES	DIM_D	DIM_C	DIM_B	DIM_A	NO OF POSN	PART NUMBER

THIS DRAWING IS A CONTROLLED DOCUMENT.

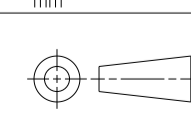
DIMENSIONS:	TOLERANCES UNLESS OTHERWISE SPECIFIED:	OWN G. RAMESH 08NOV2017	 TE Connectivity
mm	0 PLC ±	CHK J. OLSON 08NOV2017	
 1 PLC ±0.3 2 PLC ±0.13 3 PLC ± 4 PLC ± ANGLES ±0.5 FINISH	APVD J. OLSON 08NOV2017	NAME RECEPTACLE ASSEMBLY, VERTICAL, DOUBLE ROW SURFACE MOUNT, AMPMODU System 50	
MATERIAL		PRODUCT SPEC	RESTRICTED TO
		APPLICATION SPEC	SIZE A1
		WEIGHT	CAGE CODE
		CUSTOMER DRAWING	DRAWING NO C=104550
			SCALE 5:1
			SHEET 2 OF 2
			REV V

单击下面可查看定价，库存，交付和生命周期等信息

[>>TE Connectivity\(泰科\)](#)