

SPECIFICATION CONTROL DRAWING

0024F4424

CHEMINAX

100 OHM, AWG 24, 19 STRANDS OF AWG 36, TWINAXIAL CABLE

Date 5-1-13

Revision C

THIS SPECIFICATION SHEET FORMS A PART OF THE LATEST ISSUE OF RAYCHEM SPECIFICATION 1200.

CONSTRUCTION DETAILS

ELECTRICAL CHARACTERISTICS

DIMENSIONS ARE NOMINAL VALUES IN INCHES UNLESS OTHERWISE DESIGNATED.

| | |
|--------------------------|---------------------------------------|
| CHARACTERISTIC IMPEDANCE | 100 ± 10 ohms, Method D, 1 to 100 MHz |
| MUTUAL CAPACITANCE | 13.4 pF/ft. (nominal) |
| VELOCITY OF PROPAGATION | 78% (nominal) |

ADDITIONAL REQUIREMENTS

ELECTRICAL

| | |
|---|---------------------------------------|
| CONDUCTOR RESISTANCE (prior to cabling) | 28.1 ohms/1000 ft. (maximum) |
| INSULATION RESISTANCE | 10,000 megohms (minimum) for 1000 ft. |
| JACKET FLAWS | |
| SPARK TEST | 1.0 kV (rms) |
| IMPULSE TEST | 6.0 kV (peak) |
| VOLTAGE WITHSTAND (DIELECTRIC) | 1500 volts (rms) (minimum) |

ENVIRONMENTAL

| | |
|--|----------------------------|
| FLAMMABILITY | Method B |
| HEAT SHOCK | 225°C |
| LOW TEMPERATURE-COLD BEND | -55°C/4.00 inch mandrel |
| VOLTAGE WITHSTAND (Post Environmental) | 1000 volts (rms), 1 minute |

PHYSICAL

| | |
|--|--|
| INSULATION (DIELECTRIC) (Prior to Cabling) | |
| ELONGATION | 50% (minimum) |
| TENSILE STRENGTH | 600 lbf/in ² (minimum) |
| JACKET | |
| ELONGATION | 200% (minimum) |
| TENSILE STRENGTH | 2000 lbf/in ² (minimum) |
| JACKET THICKNESS | .008 inch (nominal) |
| SHIELD COVERAGE | 92% (minimum) (1 st shield) 85% (minimum) (2 nd shield) |

WEIGHT 21.3 lbs/1000 ft. (maximum)

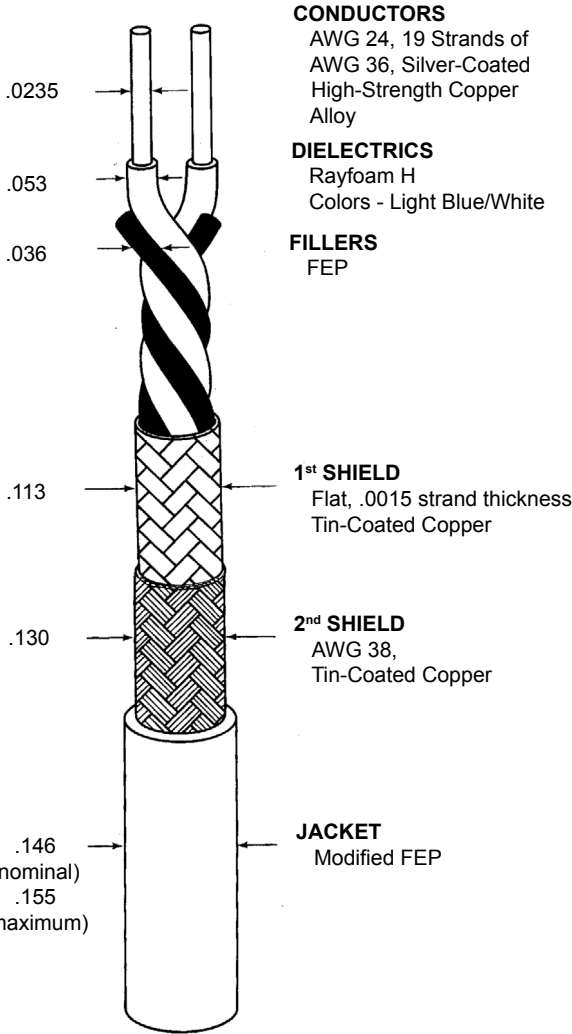

Outer jacket color will be translucent blue (designated by a "-6X" appended to the part number, e.g. 0024F4424-6X) unless otherwise specified.

Designate outer jacket color with a dash number in accordance with MIL-STD-681. Other codes and suffixes may be added to the part number, as necessary, to capture any additional requirements imposed by the purchase order.

Users should evaluate the suitability of this product for their application. Specifications are subject to change without notice. Tyco Electronics Corporation also reserves the right to make changes in materials or processing, which do not affect compliance with any specification, without notification to Buyer.



Raychem Wire & Cable
501 Oakeside Avenue
Redwood City, California 94063-3800
1-800-227-8816 Fax: 1-650-361-6297

THIS SPECIFICATION SHEET TAKES PRECEDENCE OVER DOCUMENTS REFERENCED HEREIN. REFERENCED DOCUMENTS SHALL BE OF THE ISSUE IN EFFECT ON DATE OF INVITATION FOR BID.

| TABLE I. ELECTRICAL PARAMETERS | | |
|---------------------------------------|---|--|
| FREQUENCY (MHz) | INSERTION LOSS dB/100m (maximum) | RETURN LOSS dB/100m (minimum) |
| 1.0 | 2.7 | 20.0 |
| 4.0 | 5.6 | 23.0 |
| 8.0 | 7.9 | 24.5 |
| 10.0 | 8.9 | 25.0 |
| 16.0 | 11.2 | 25.0 |
| 20.0 | 12.7 | 25.0 |
| 25.0 | 14.2 | 24.2 |
| 31.25 | 16.0 | 23.3 |
| 62.5 | 23.3 | 20.7 |
| 100.0 | 30.1 | 19.0 |

Note: Values are for reference only. Actual values shall be determined utilizing the formulas in ANSI/TIA-568-C.2.

单击下面可查看定价，库存，交付和生命周期等信息

[>>TE Connectivity\(泰科\)](#)