

REVISIONS					
P	LTR	DESCRIPTION	DATE	DMN	APVD
M		REVISED PER ECO 20-003564	5-27-20	CT	DM

- THIS PLUG WILL MATE TO ANY SIZE 6, 104 POSITION RECEPTACLE IN THE AMPLIMITE SERIES.
- CONNECTOR SUPPLIED WITHOUT CONTACTS; SHOWN FOR ILLUSTRATION ONLY.
- BE-CU RETENTION CLIPS ARE INCLUDED AND INSTALLED WITH TINES POINTING TOWARDS MATING FACE.
- OVERALL DIMENSIONS DO NOT INCLUDE RAISED CAVITY IDENTIFICATION.
- MARKING ON FAR SIDE REFERS TO WIDE SIDE OF KEYSTONE. NEAR SIDE REFERS TO NARROW SIDE OF KEYSTONE.

- 6 100% INSPECTION REQUIRED PER BOEING 1B01:
 - A. VISUAL
 - B. DWV
 - C. IR
- 7 CUSTOMER REQUIRES SINGLE LOT DATE CODE.
- 8 SPECIAL REQUIREMENTS:
 - A. TEST TWO CONNECTORS PER LOT FOR COMPLIANCE TO GROMMET PEEL STRENGTH REQUIREMENTS
 - B. TEST ALL CIRCUIT CAVITIES FOR MISALIGNMENT OR EXCESSIVE ADHESIVE

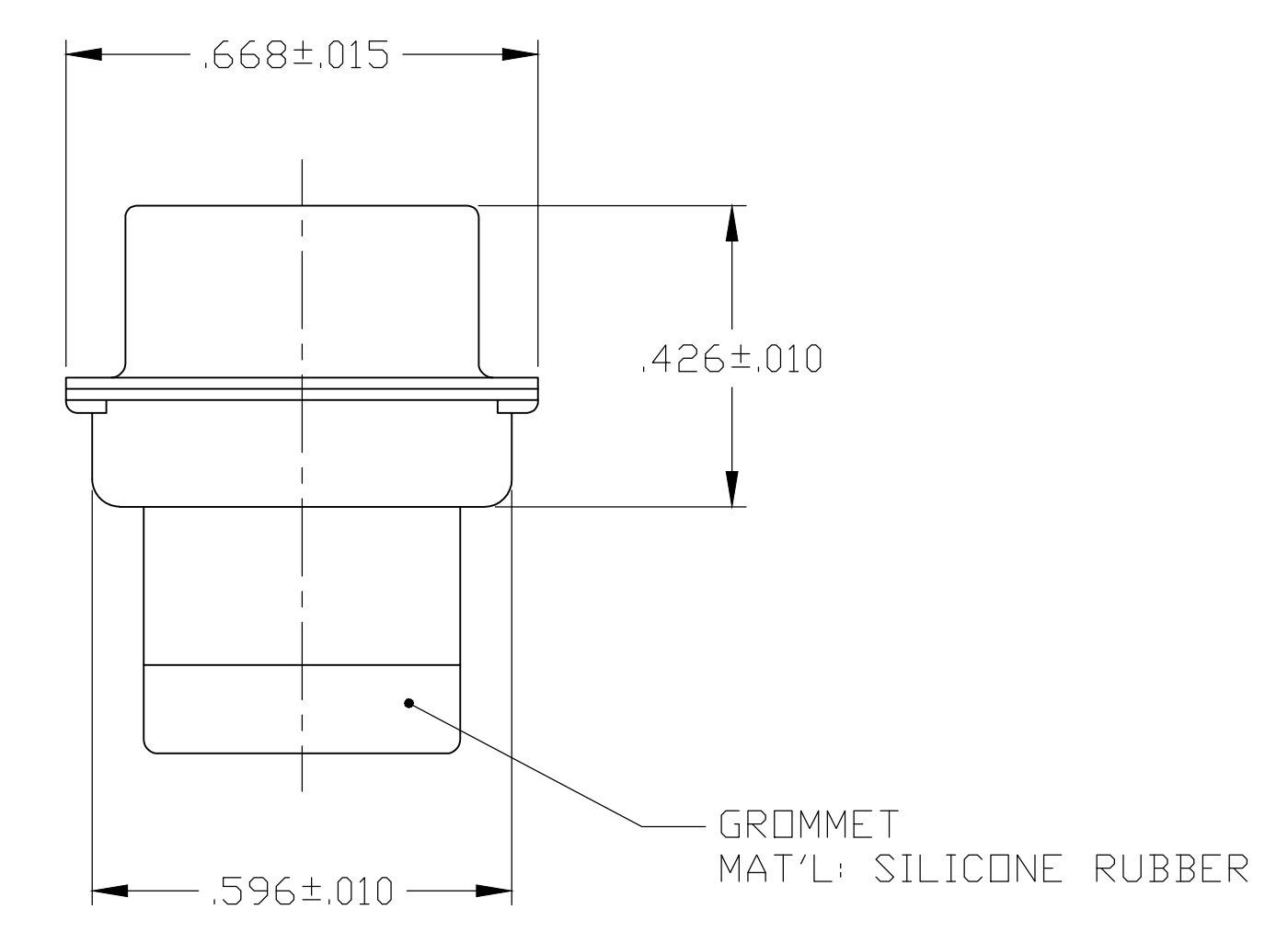
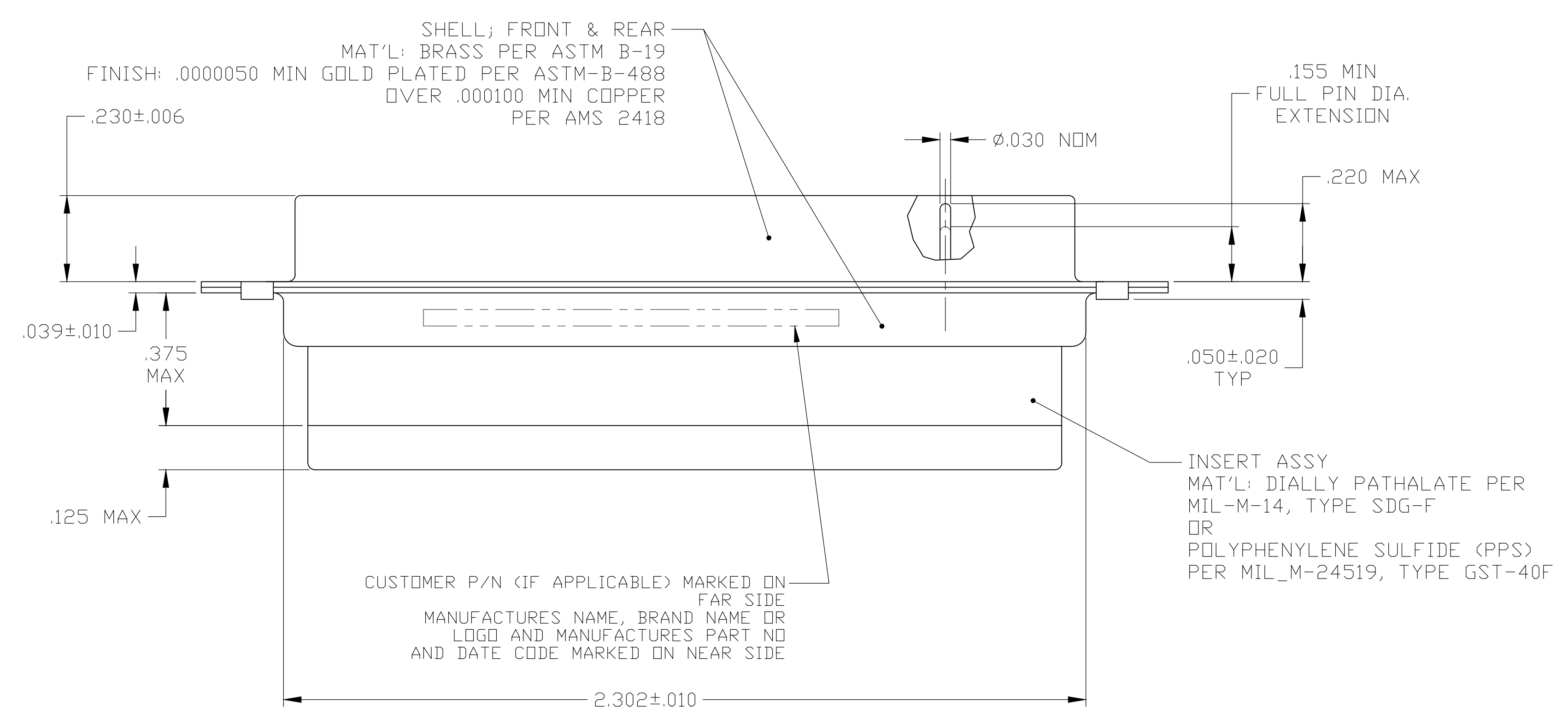
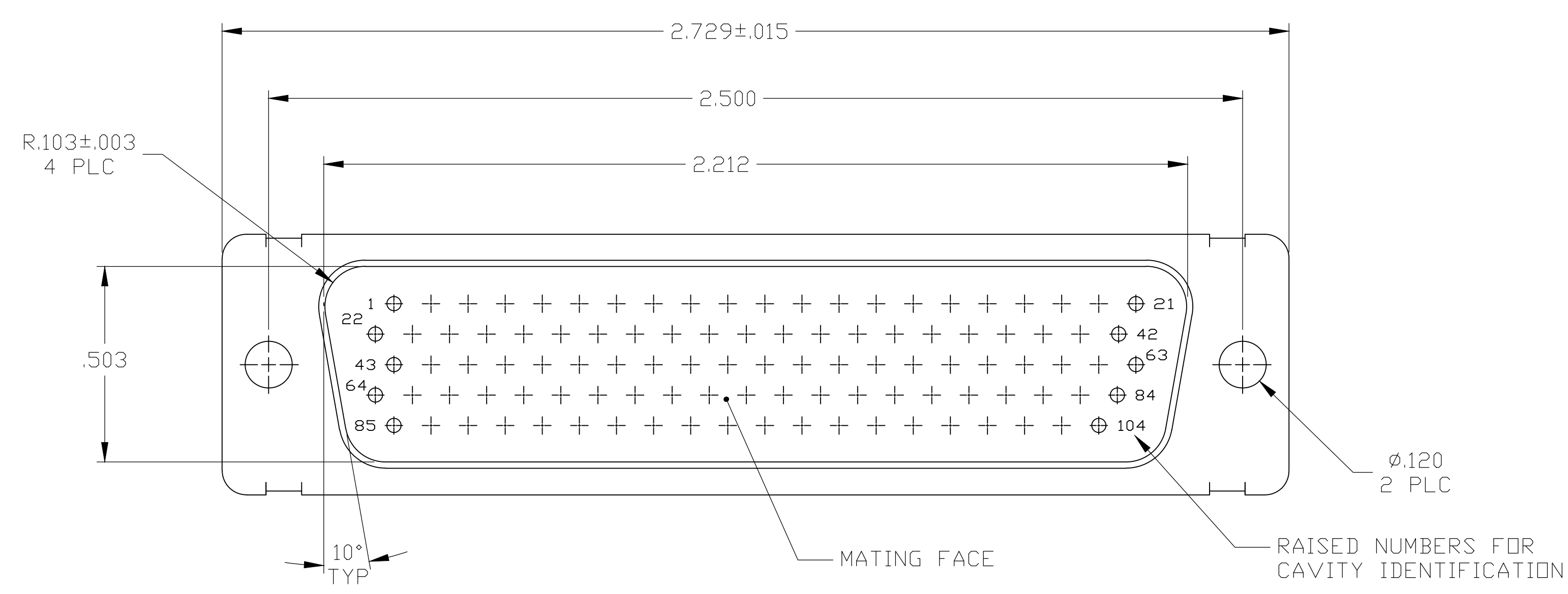

REMARKS	MARKED CUSTOMER P/N	MARKED MFG P/N	ASSEMBLY NUMBER
	1B01-036PHW	1-211678-1	1-211678-1
		211678-4	211678-7
OBSOLETE	1B01-036	211678-1	211678-6
OBSOLETE			211678-5
		211678-4	211678-4
OBSOLETE		211678-3	211678-3
	2A065-018V-001	211678-2	211678-2
	1B01-036	211678-1	211678-1

THIS DRAWING IS A CONTROLLED DOCUMENT.

DIMENSIONS: INCHES	TOLERANCES UNLESS OTHERWISE SPECIFIED:	0 PLC ± -	1 PLC ± -	2 PLC ± -	3 PLC ± .005	4 PLC ± -	ANGLES ± -
--------------------	--	-----------	-----------	-----------	--------------	-----------	------------

MATERIAL: SEE CALLOUTS	FINISH: SEE CALLOUTS	WEIGHT: 0.000000	SIZE: A1	CAGE CODE: 00779	DRAWING NO: 211678	RESTRICTED TO: -
------------------------	----------------------	------------------	----------	------------------	--------------------	------------------

CUSTOMER DRAWING SCALE: 4:1 SHEET 1 OF 1 REV M

单击下面可查看定价，库存，交付和生命周期等信息

[>>TE Connectivity\(泰科\)](#)