Table of Contents

Z-DOK and Z-DOK + Connectors	163-176
Product Line Overview	164
Electrical Performance and Applications	165-167
Z-DOK +2 Connector	168, 169
Z-DOK +4 Connector	170, 171
Z-DOK +6 Connector	172-174
Sequencing Chart	175
Work Sheet	176

Product Line Overview

Product Facts

Z-DOK Connector

- Data rates up to 10+ Gb/s
- Familiar robust blindmate design derived from CHAMP .050 Series connector family
- Maximizes data throughput while minimizing pair to pair crosstalk and impedance discontinuities
- Available in size increments of 8 to 72 differential pairs
- Sequenced mating of ESD, ground and signal circuits to insure proper initialization of the mating cards
- Unique ESD contact system to insure dissipation of ESD in a make first break last mating sequence

Product Facts

Z-DOK + Connector

- The CHAMP Z-DOK + connector is the latest addition to the CHAMP connector family
- Includes high speed and utility contacts in one connector
- Operating bandwidth up to 10+ Gb/s
- Robust 4 row, blindmate design
- Utilizes TRI-Q differential pair contact system providing 2 to 1 signal to ground ratio
- Uniform 100 ohm impedance with less than 3% crosstalk
- Available in 8 pair increments from 8 to 72 pair
- Utility contacts can be arranged on either end of the connector
- Utility contacts are available in 4 lengths to accommodate power, ground, ESD and sensing design requirements

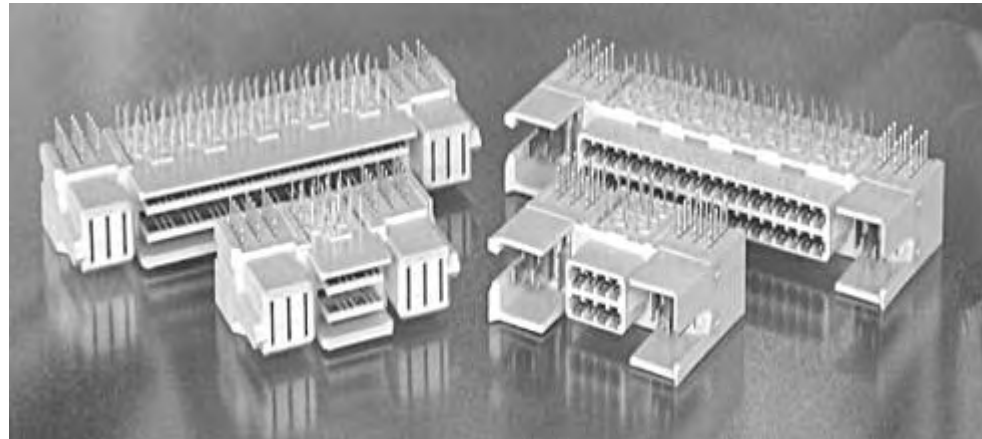

The CHAMP Z-DOK connector system includes two options for system designers. The first option is the Z-DOK connector, which provides the following features:

1. Robust, blind-mateable, high speed connector
2. Data rates in excess of 10+ Gb/s (Double XAUI speeds)
3. Differential pair, 100 ohm, low crosstalk
4. Available with and without sensing contacts
5. Position sizes from 8 to 72 differential pair in increments of 8 differential pair modules
6. Unique TRI-Q contact system that provides a 2 to 1 signal to ground ratio for maintaining superior signal integrity

The second option is the CHAMP Z-DOK + connector, which includes a high speed section with the same features as standard the Z-DOK connector and adds up to 3 "Utility" modules to each side of the connector. Each "Utility" module provides flexibility for systems designers to include power, ground, ESD and sensing functions to I/O adapter cards and docking applications.

The Z-DOK + connector system can be provided in the same position sizes as the standard Z-DOK connector (8 to 72 differential pair). The Utility modules can be added to either side of the high speed section with a maximum of three (3) on each side. This arrangement will provide a total of six (6) positions for the power, ground, ESD and sensing functions. Four different length contacts can be loaded into the "Utility" modules to provide the ultimate design flexibility.

Applications

- The Z-DOK and Z-DOK + connector systems are suitable for use in high speed, co-planar docking applications.
 - Enterprise Switching Equipment
 - High Speed Telecommunications Equipment
 - Mid Range and High End Servers
 - Storage Area Networks
 - High Speed Custom Platforms
- The Z-DOK connector TRI-Q contact arrangement is well suited for high speed serial switching architectures and the robust design assures a highly reliable interconnect between host and media adapter cards. Z-DOK connectors can handle escalating data rates without sacrificing line density to achieve higher signal integrity. If I/O flexibility is what you seek, the Z-DOK connector will help insure the longevity of your packaging scheme through ease in changeability.

Electrical Performance and Applications

Availability

Fully validated SPICE models: E-mail requests to modeling@te.com

Samples: E-mail requests to zdok@te.com

Pro/E models and IGES models: E-mail requests to TECAD@te.com

Application Specification 114-13068

Product Specification Design Objectives 108-1985

<http://zdok.te.com>

Z-DOK + Connector Electrical Performance

3.125 Gb/s over 6" of FR4

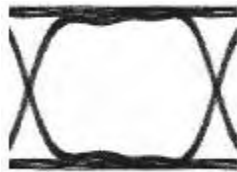

Maximum Opening — 89.2%
Jitter — 2.2% U.I.

10 Gb/s over 6" of FR4

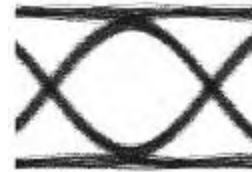

Maximum Opening — 69.8%
Jitter — 10.5% U.I.

IGES is a trademark of IAMBA Networks, Inc.

PRO/E is a trademark of Parametric Technology Corp.

Electrical Performance and Applications (Continued)

TRI-Q Contact System

Each differential pair is carefully designed to be in close proximity to a dedicated ground, providing true symmetrical impedance and low noise in a 100 Ω system.

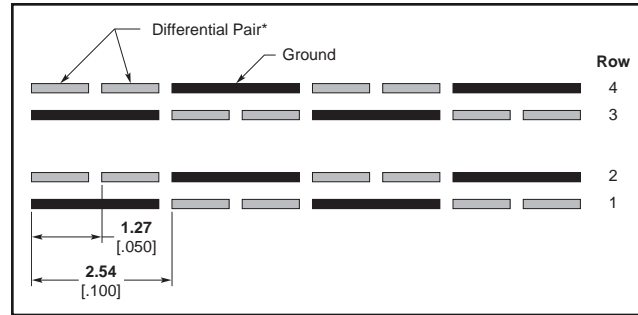

Contact Interface

* The differential pair contacts may be used for single ended lines. Consult TE for more information.

The ground contacts are confined to rows B & E to simplify trace routing, control pair-to-pair crosstalk, and to minimize impedance discontinuities at the connector to board interface.

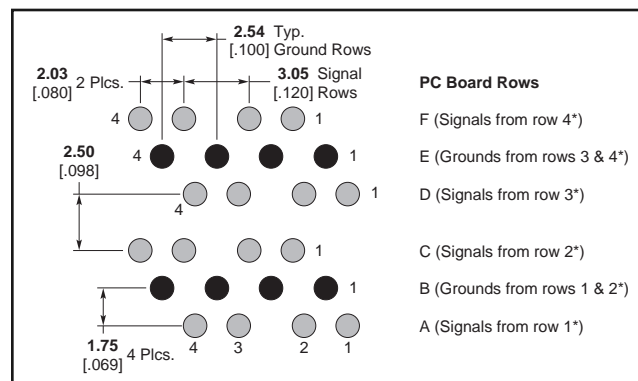

Host Board Layout

* Contact interface rows.

Host and Adapter Board Trace Routing
Suggested two-layer routing pattern

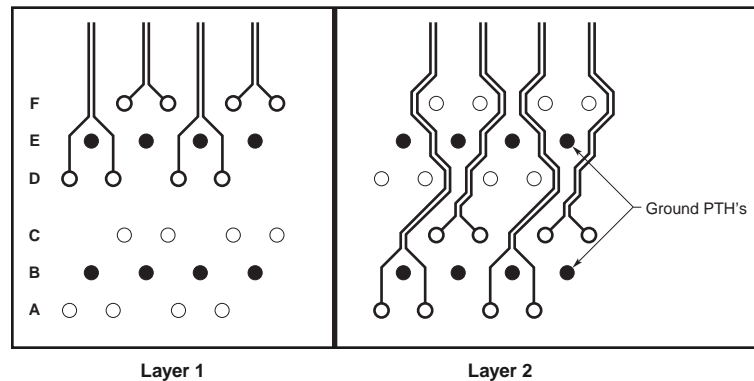

Electrical Performance and Applications (Continued)

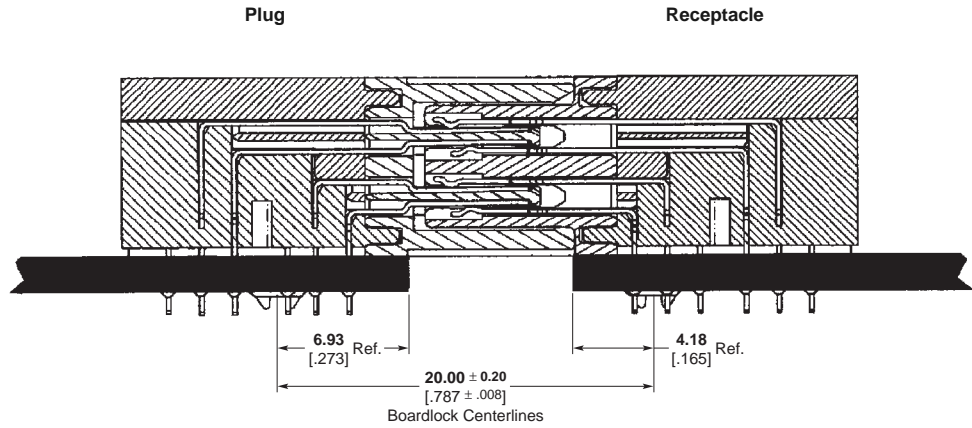

Z-DOK + Connector Applications

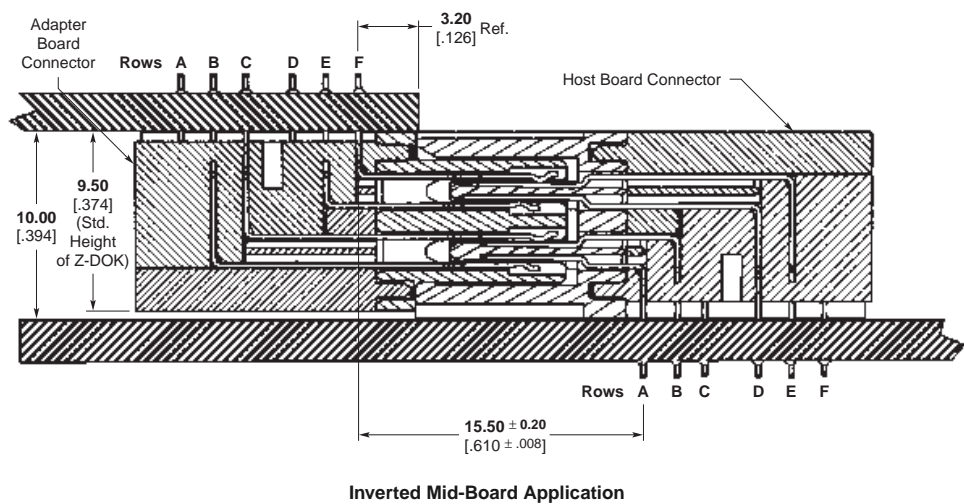
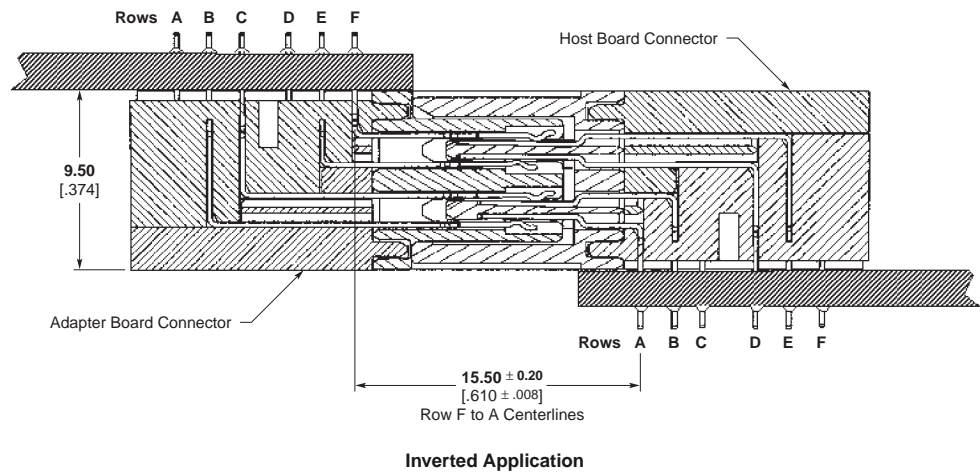

6 Z-DOK and Z-DOK + Connectors

Z-DOK +2 Connector System

Host

Material and Finish

Housings — Polyester, UL 94V-0 rated, natural color

Signal and Signal Ground

Contacts — Copper alloy, 0.76 µm min. gold in contact area, 2.54 µm min. tin on PCB tails, over 1.27 µm min. nickel overall

Utility Contacts — Phosphor bronze, 0.76 µm min. gold in contact area, 2.54 µm min. tin on PCB tails, over 1.27 µm min. nickel overall

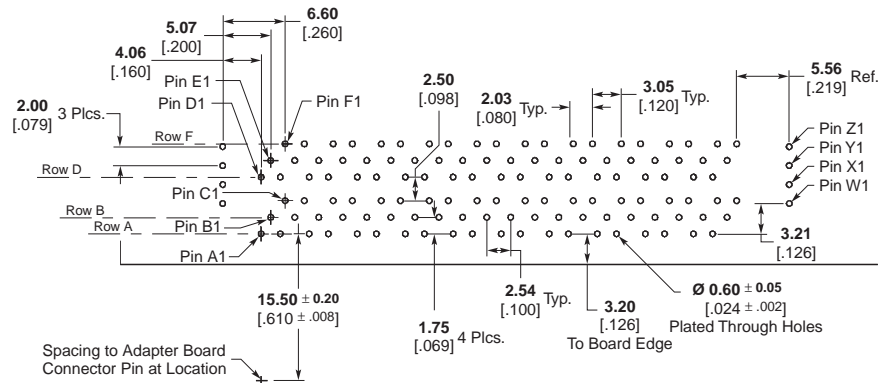
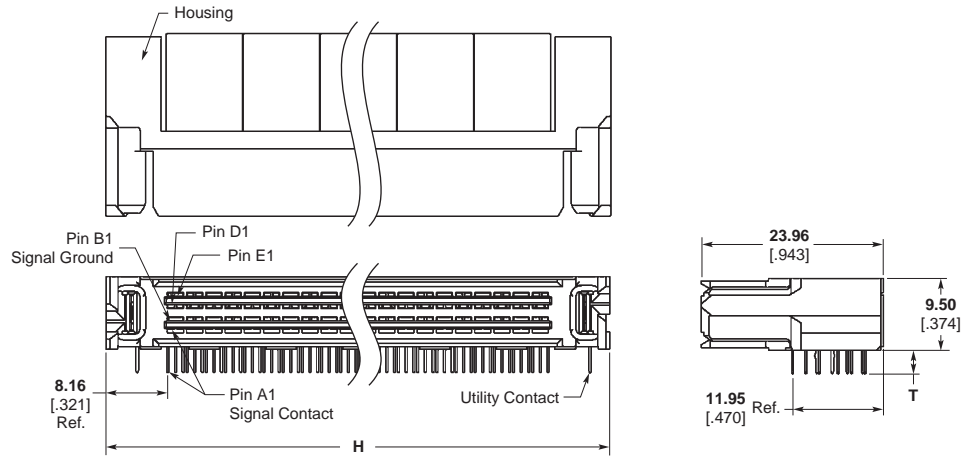

Recommended PC Board Footprint

Z-DOK +2 Host Connector Part Numbers

Type	Dim. H	Dim. T	Number of Utility Contacts	Number of Diff. Pairs	Part Number
Host Connector +2	25.96 1.022	3.10 .122	2	8	6367590-1
	36.12 1.422	3.10 .122	2	16	6367590-2
	46.28 1.822	3.10 .122	2	24	6367590-3
	56.44 2.222	3.10 .122	2	32	6367590-4
	66.60 2.622	3.10 .122	2	40	6367590-5
	76.76 3.022	3.10 .122	2	48	6367590-6
	86.92 3.422	3.10 .122	2	56	6367590-7
	97.08 3.822	3.10 .122	2	64	6367590-8
	107.24 4.222	3.10 .122	2	72	6367590-9

Different Tail Lengths available upon request, contact TE.

Note: All part numbers are RoHS compliant.

Z-DOK +2 Connector System (Continued)

Adapter

Material and Finish

Housings — Polyester, UL 94V-0 rated, natural color

Signal and Signal Ground

Contacts — Copper alloy, 0.76 µm min. gold in contact area, 2.54 µm min. tin on PCB tails, over 1.27 µm min. nickel overall

Utility Contacts — Phosphor bronze, 0.76 µm min. gold in contact area, 2.54 µm min. tin on PCB tails, over 1.27 µm min. nickel overall

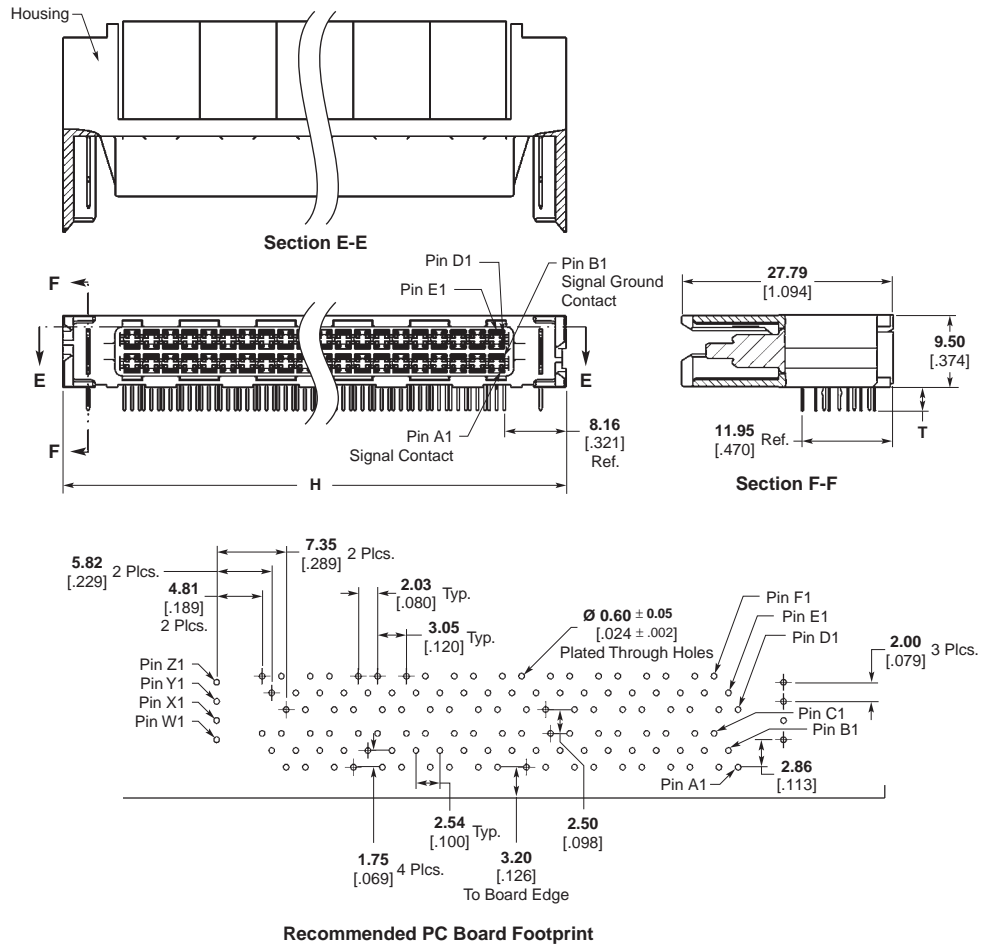

Z-DOK +2 Adapter Connector Part Numbers

Type	Dim. H	Dim. T	Sequence for Utility Pin Loc. 1	Sequence for Utility Pin Loc. 2	Number of Utility Contacts	Number of Diff. Pairs	Part Number
Adapter Connector +2	56.44	3.10	4	4	2	32	6367594-1
	2.222	.122					
+2	66.60	3.10	4	4	2	40	6367595-1
	2.622	.122					

Different Tail Lengths available upon request, contact TE.

Note: All part numbers are RoHS compliant.

Z-DOK +4 Connector System

Host

Material and Finish

Housings — Polyester, UL 94V-0 rated, natural color

Signal and Signal Ground

Contacts — Copper alloy, 0.76 µm min. gold in contact area, 2.54 µm min. tin on PCB tails, over 1.27 µm min. nickel overall

Utility Contacts — Phosphor bronze, 0.76 µm min. gold in contact area, 2.54 µm min. tin on PCB tails, over 1.27 µm min. nickel overall

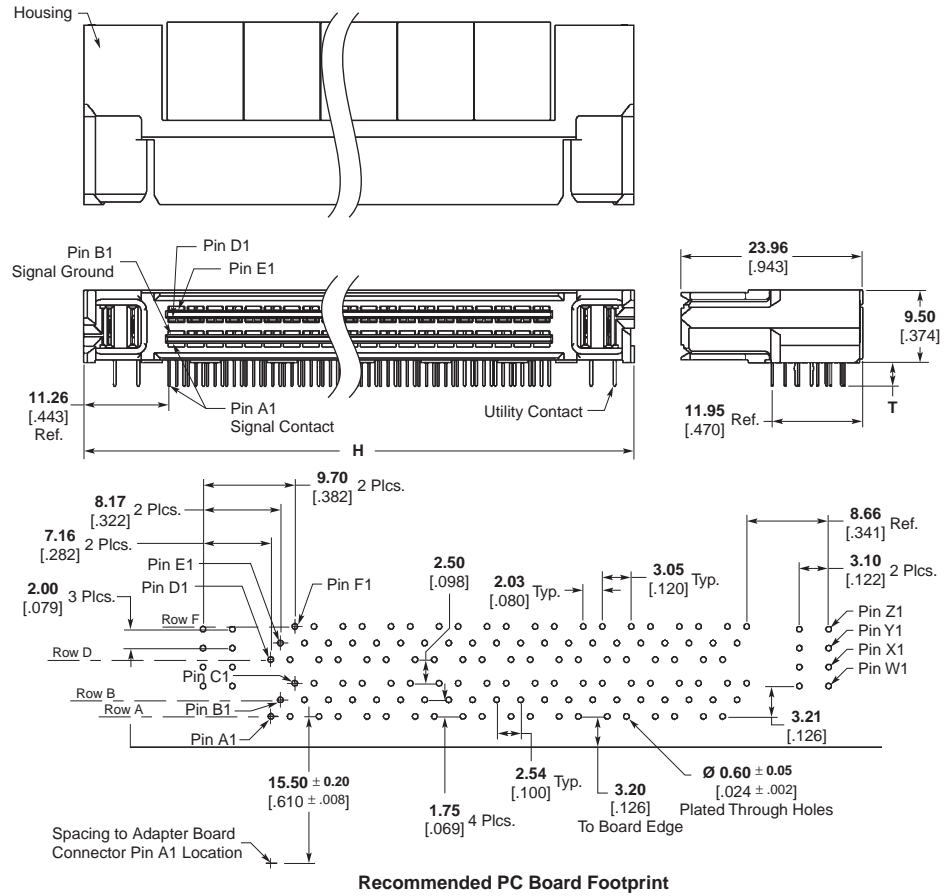

Z-DOK +4 Host Connector Part Numbers

Type	Dim. H	Dim. T	Number of Utility Contacts	Number of Diff. Pairs	Part Number
Host Connector +4	32.16	3.10	4	8	6367580-1
	1.266	.122			
	42.32	3.10	4	16	6367580-2
	1.666	.122			
	52.48	3.10	4	24	6367580-3
	2.066	.122			
	62.64	3.10	4	32	6367580-4
	2.466	.122			
	72.80	3.10	4	40	6367580-5
2.866	.122				
82.96	3.10	4	48	6367580-6	
3.266	.122				
93.12	3.10	4	56	6367580-7	
3.666	.122				
103.28	3.10	4	64	6367580-8	
4.066	.122				
113.44	3.10	4	72	6367580-9	
4.466	.122				

Different Tail Lengths available upon request, contact TE.

Z-DOK +4 Host Connector Part Numbers (Continued)

Type	Dim. H	Dim. T	Number of Utility Contacts	Number of Diff. Pairs	Part Number
Host Connector +4	32.16	3.85	4	8	6367680-1
	1.266	.152			
	42.32	3.85	4	16	6367680-2
	1.666	.152			
	52.48	3.85	4	24	6367680-3
	2.066	.152			
	62.64	3.85	4	32	6367680-4
	2.466	.152			
	72.80	3.85	4	40	6367680-5
2.866	.152				
82.96	3.85	4	48	6367680-6	
3.266	.152				
93.12	3.85	4	56	6367680-7	
3.666	.152				
103.28	3.85	4	64	6367680-8	
4.066	.152				
113.44	3.85	4	72	6367680-9	
4.466	.152				

Different Tail Lengths available upon request, contact TE.

Note: All part numbers are RoHS compliant.

Z-DOK +4 Connector System (Continued)

Adapter

Material and Finish

Housings — Polyester, UL 94V-0 rated, natural color

Signal and Signal Ground Contacts

— Copper alloy, 0.76 µm min. gold in contact area, 2.54 µm min. tin on PCB tails, over 1.27 µm min. nickel overall

Utility Contacts — Phosphor bronze, 0.76 µm min. gold in contact area, 2.54 µm min. tin on PCB tails, over 1.27 µm min. nickel overall

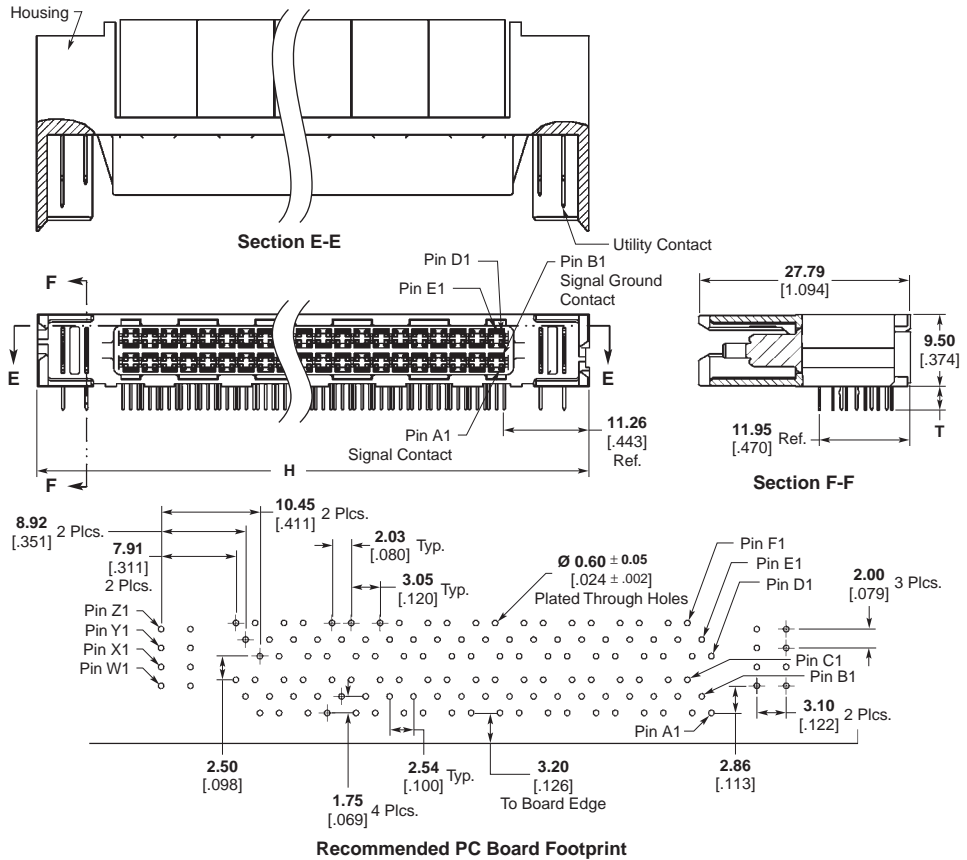

Z-DOK +4 Adapter Connector Part Numbers

Type	Dim. H	Dim. T	Sequence for Utility Pin Loc. 1	Sequence for Utility Pin Loc. 2	Sequence for Utility Pin Loc. 3	Sequence for Utility Pin Loc. 4	Number of Utility Contacts	Number of Diff. Pairs	Part Number
Adapter Connector +4	36.12 1.422	3.10 .122	4	3	3	4	4	16	6367582-1
	46.28 1.822	3.10 .122	4	3	3	4	4	24	6367583-1
	56.44 2.222	3.10 .122	4	3	3	4	4	32	6367584-1
	56.44 2.222	3.10 .122	4	1	3	4	4	32	6367584-2
	56.44 2.222	3.10 .122	3	2	2	3	4	32	6367584-3
	56.44 2.222	3.10 .122	2	2	3	3	4	32	6367584-4
	76.76 3.022	3.10 .122	4	3	3	4	4	48	6367586-1
	76.76 3.022	3.10 .122	3	4	4	3	4	48	6367586-2
	76.76 3.022	3.10 .122	1	4	3	2	4	48	6367586-3

Different Tail Lengths available upon request, contact TE.

Note: All part numbers are RoHS compliant.

Z-DOK +6 Connector System

Host

Material and Finish

Housings — Polyester, UL 94V-0 rated, natural color

Signal and Signal Ground

Contacts — Copper alloy, 0.76 µm min. gold in contact area, 2.54 µm min. tin on PCB tails, over 1.27 µm min. nickel overall

Utility Contacts — Phosphor bronze, 0.76 µm min. gold in contact area, 2.54 µm min. tin on PCB tails, over 1.27 µm min. nickel overall

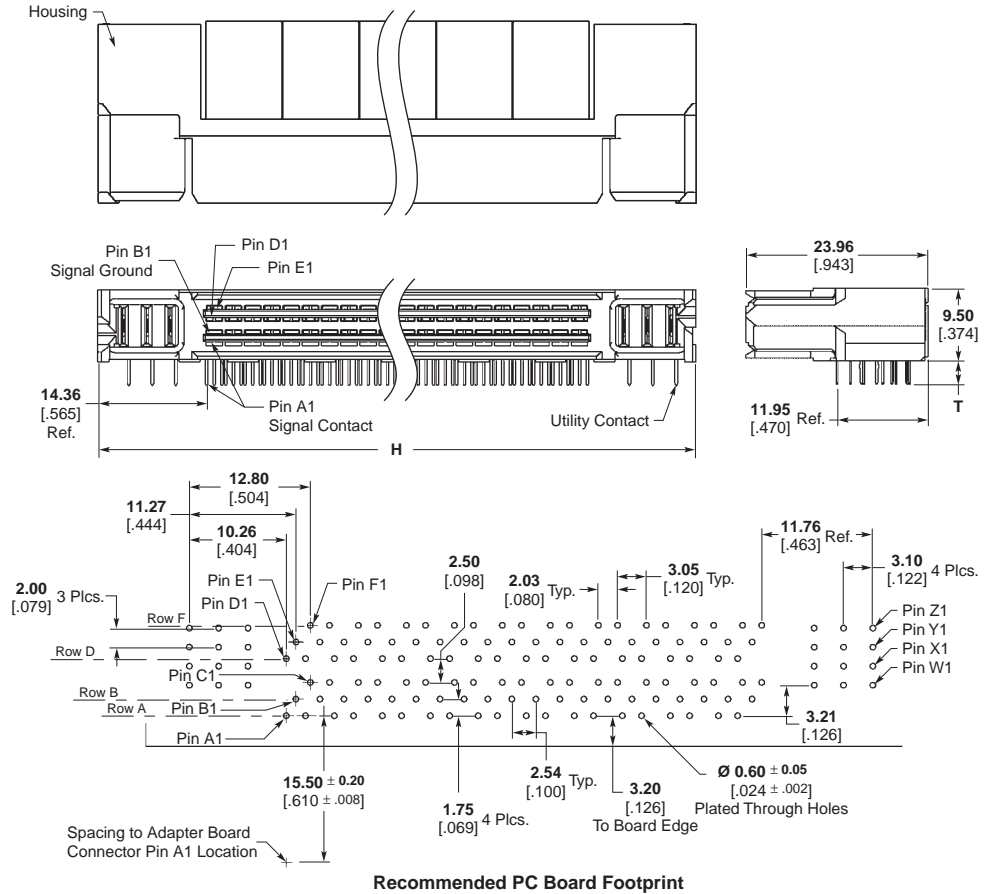

Z-DOK +6 Host Connector Part Numbers

Type	Dim. H	Dim. T	Number of Utility Contacts	Number of Diff. Pairs	Part Number
Host Connector +6	38.36 1.510	3.10 .122	6	8	6367550-1
	48.52 1.910	3.10 .122	6	16	6367550-2
	58.68 2.310	3.10 .122	6	24	6367550-3
	68.84 2.710	3.10 .122	6	32	6367550-4
	79.00 3.110	3.10 .122	6	40	6367550-5
	89.16 3.510	3.10 .122	6	48	6367550-6
	99.32 3.910	3.10 .122	6	56	6367550-7
	109.48 4.310	3.10 .122	6	64	6367550-8
	119.64 4.710	3.10 .122	6	72	6367550-9

Different Tail Lengths available upon request, contact TE.

Note: All part numbers are RoHS compliant.

Z-DOK +6 Connector System (Continued)

Adapter

Material and Finish

Housings — Polyester, UL 94V-0 rated, natural color

Signal and Signal Ground

Contacts — Copper alloy, 0.76 µm min. gold in contact area, 2.54 µm min. tin on PCB tails, over 1.27 µm min. nickel overall

Utility Contacts — Phosphor bronze, 0.76 µm min. gold in contact area, 2.54 µm min. tin on PCB tails, over 1.27 µm min. nickel overall

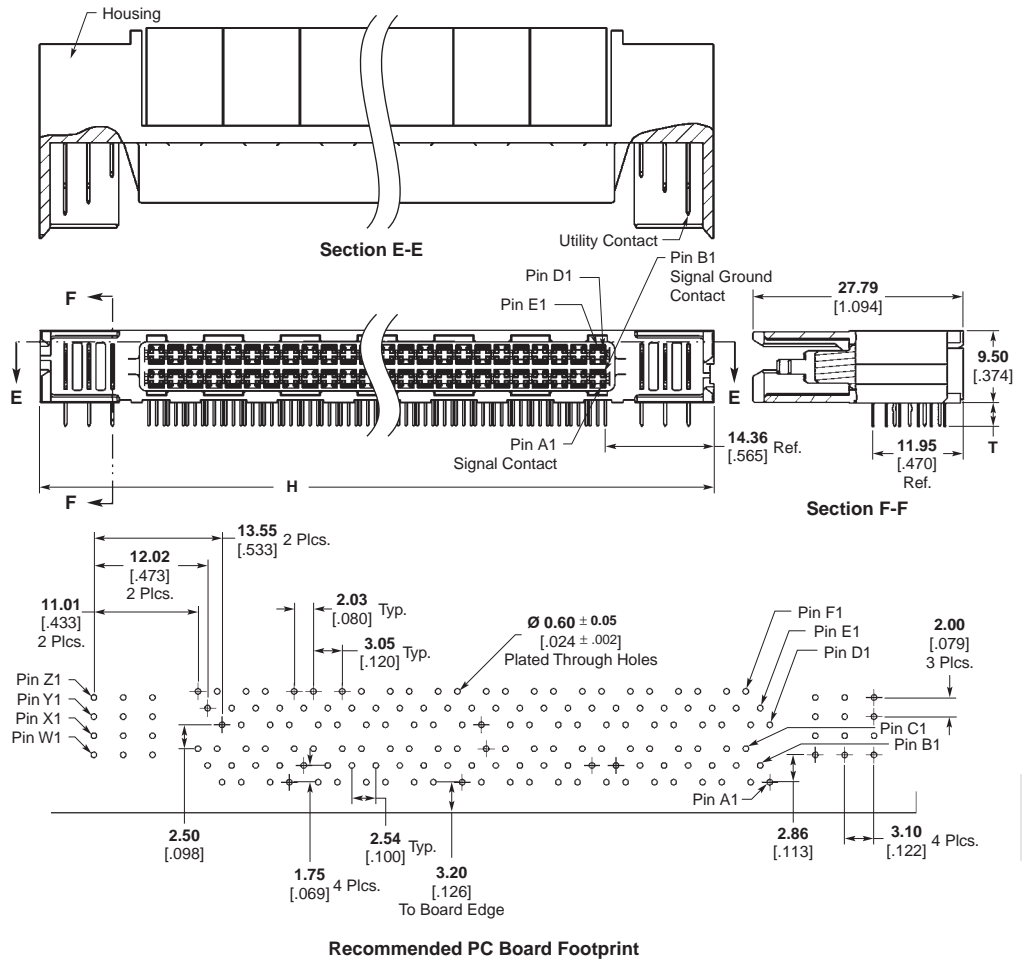

Z-DOK +6 Connector System (Continued)

Z-DOK +6 Adapter Connector Part Numbers

Type	Dim. H	Dim. T	Sequence for Utility Pin Loc. 1	Sequence for Utility Pin Loc. 2	Sequence for Utility Pin Loc. 3	Sequence for Utility Pin Loc. 4	Sequence for Utility Pin Loc. 5	Sequence for Utility Pin Loc. 6	Number of Utility Contacts	Number of Diff. Pairs	Part Number
Adapter Connector +6	38.36 1.510	3.10 .122	4	3	2	2	3	4	6	8	6367551-1
	38.36 1.510	3.10 .122	1	2	4	4	2	2	6	8	6367551-2
	48.52 1.910	3.10 .122	4	3	2	2	3	4	6	16	6367552-1
	79.00 3.110	3.10 .122	4	3	2	2	3	4	6	40	6367555-1
	79.00 3.110	3.10 .122	4	2	1	1	2	4	6	40	6367555-2
	79.00 3.110	3.10 .122	1	2	3	3	2	1	6	40	6367555-3
	99.32 3.910	3.10 .122	4	3	2	2	3	4	6	56	6367557-1
	99.32 3.910	3.10 .122	4	2	2	2	2	4	6	56	6367557-2
	99.32 3.910	3.10 .122	4	3	1	1	3	4	6	56	6367557-3
	99.32 3.910	3.10 .122	2	3	4	4	3	2	6	56	6367557-4
	99.32 3.910	3.10 .122	4	3	1	2	2	4	6	56	6367557-5
	109.48 4.310	3.10 .122	4	3	2	2	3	4	6	64	6367558-1
	109.48 4.310	3.10 .122	4	3	3	3	3	4	6	64	6367558-2
	109.48 4.310	3.10 .122	4	3	1	1	3	4	6	64	6367558-3
	119.64 4.710	3.10 .122	4	3	2	2	3	4	6	72	6367559-1
	119.64 4.710	3.10 .122	2	3	4	3	2	1	6	72	6367559-2

Different Tail Lengths available upon request, contact TE.

Note: All part numbers are RoHS compliant.

Sequencing Chart

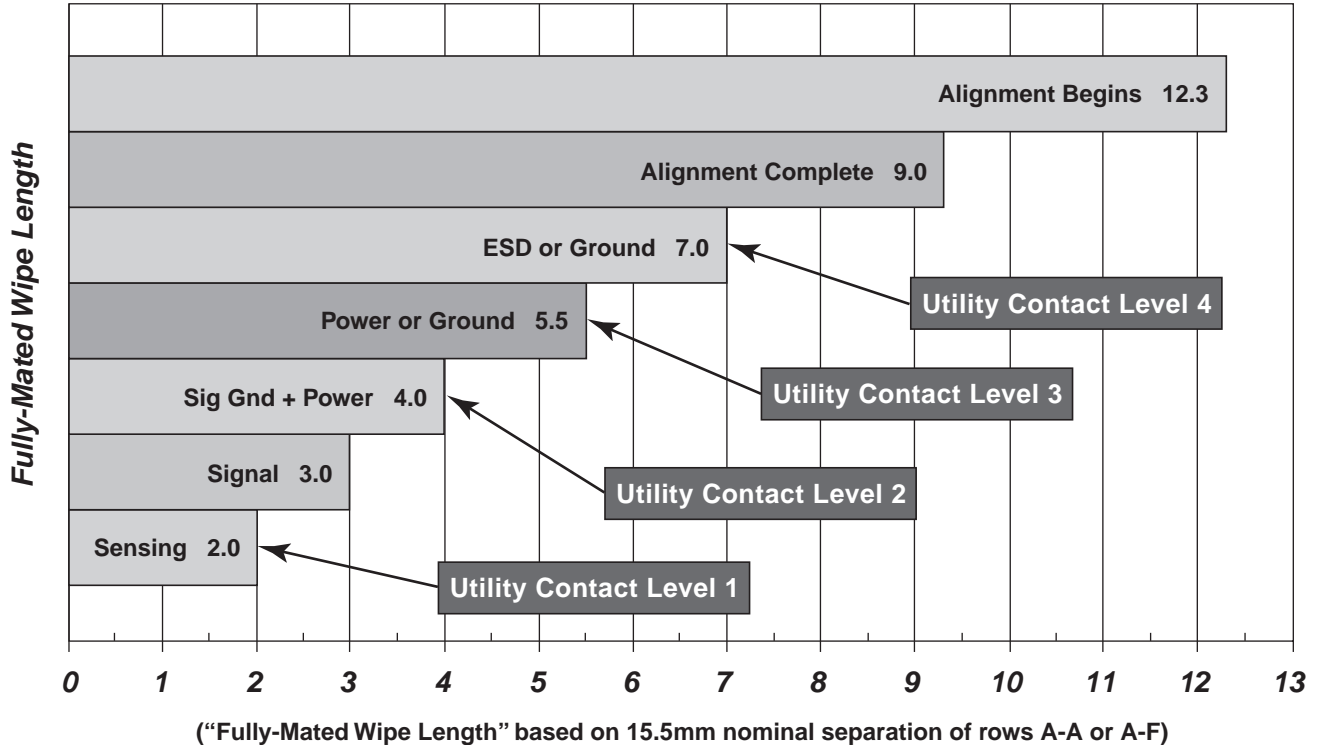

Z-DOK + Connector Sequencing Worksheet

The Z-DOK + connector system allows you to choose the sequencing for the utility contacts. This is accomplished placing the desired pin length in each location on the adapter board side

connector. The locations for each version; Z-DOK +2, Z-DOK +4, and Z-DOK +6 connectors are shown below. Using the sequencing chart from page 175, **fill in your desired sequence**

in the location of your choice. Contact your TE representative to have the next dash number on the drawing released.

Z-DOK +2 Connector

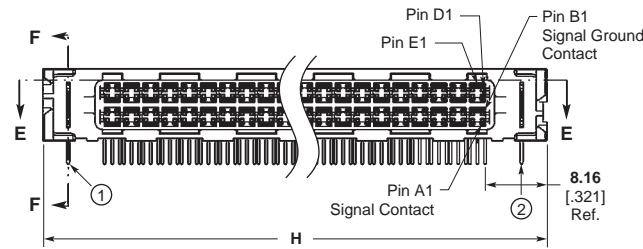

Location	①	②
Sequence		

Z-DOK +4 Connector

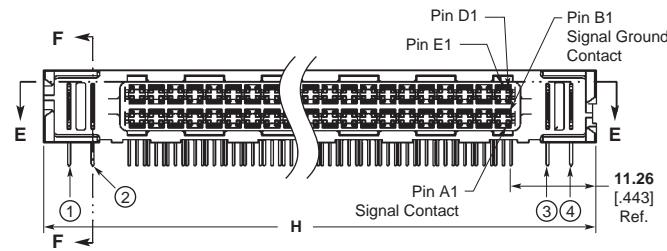

Location	①	②	③	④
Sequence				

Z-DOK +6 Connector

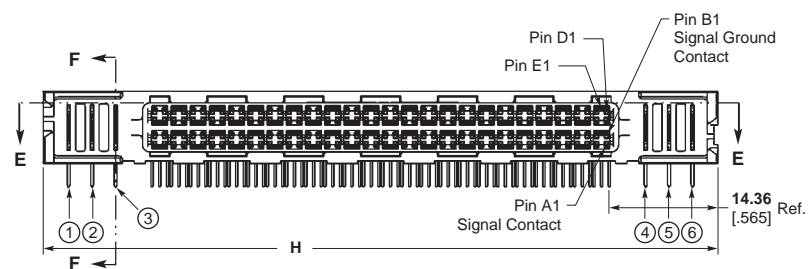

Location	①	②	③	④	⑤	⑥
Sequence						

单击下面可查看定价，库存，交付和生命周期等信息

[>>TE Connectivity\(泰科\)](#)