

REVISIONS					
P	LTR	DESCRIPTION	DATE	OWN	APVD
D3		REVISED PER ECO-12-012141	02JUL12	KH	JO
E		REVISED PER ECO-17-016552	17NOV2017	RS	JO

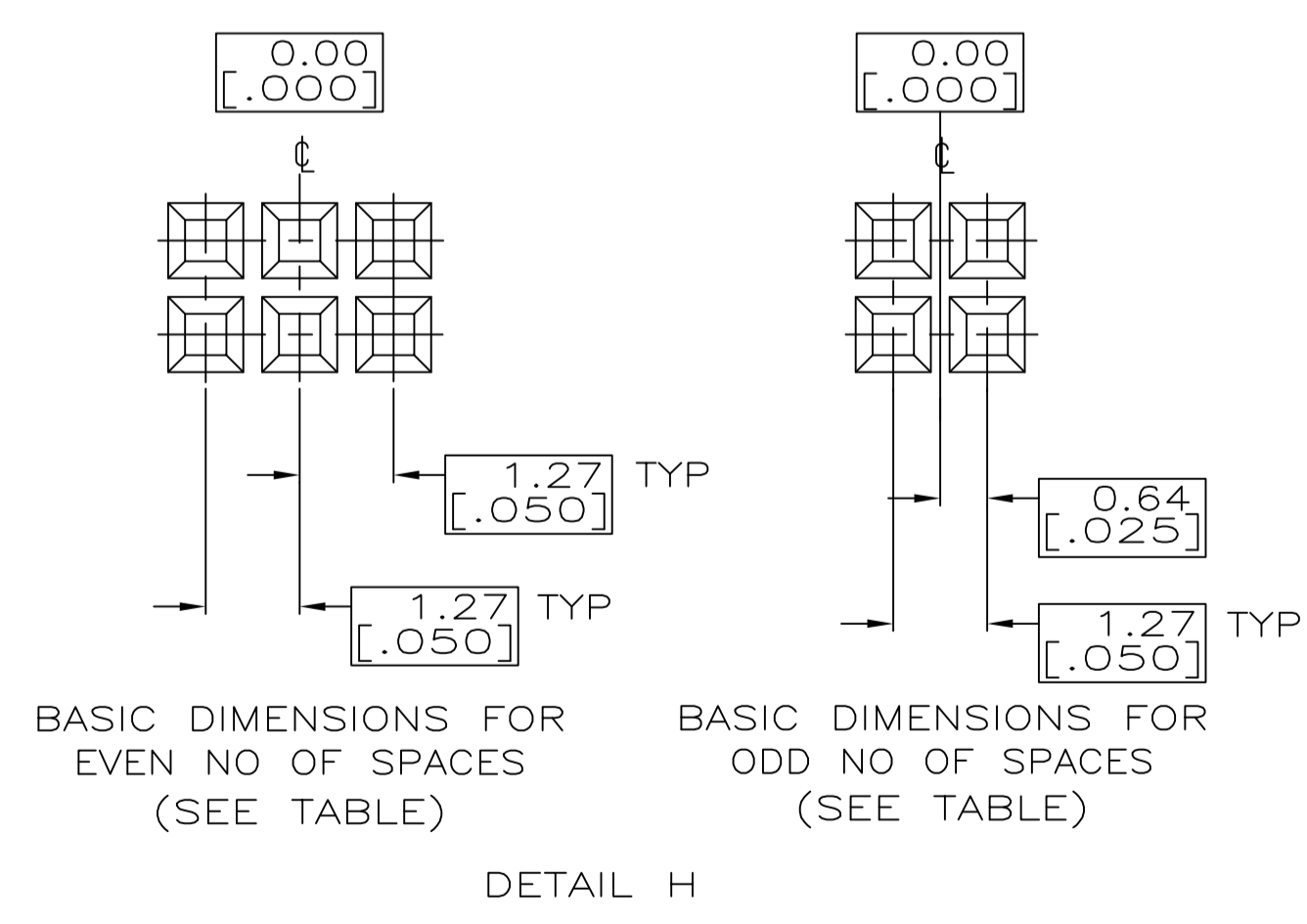
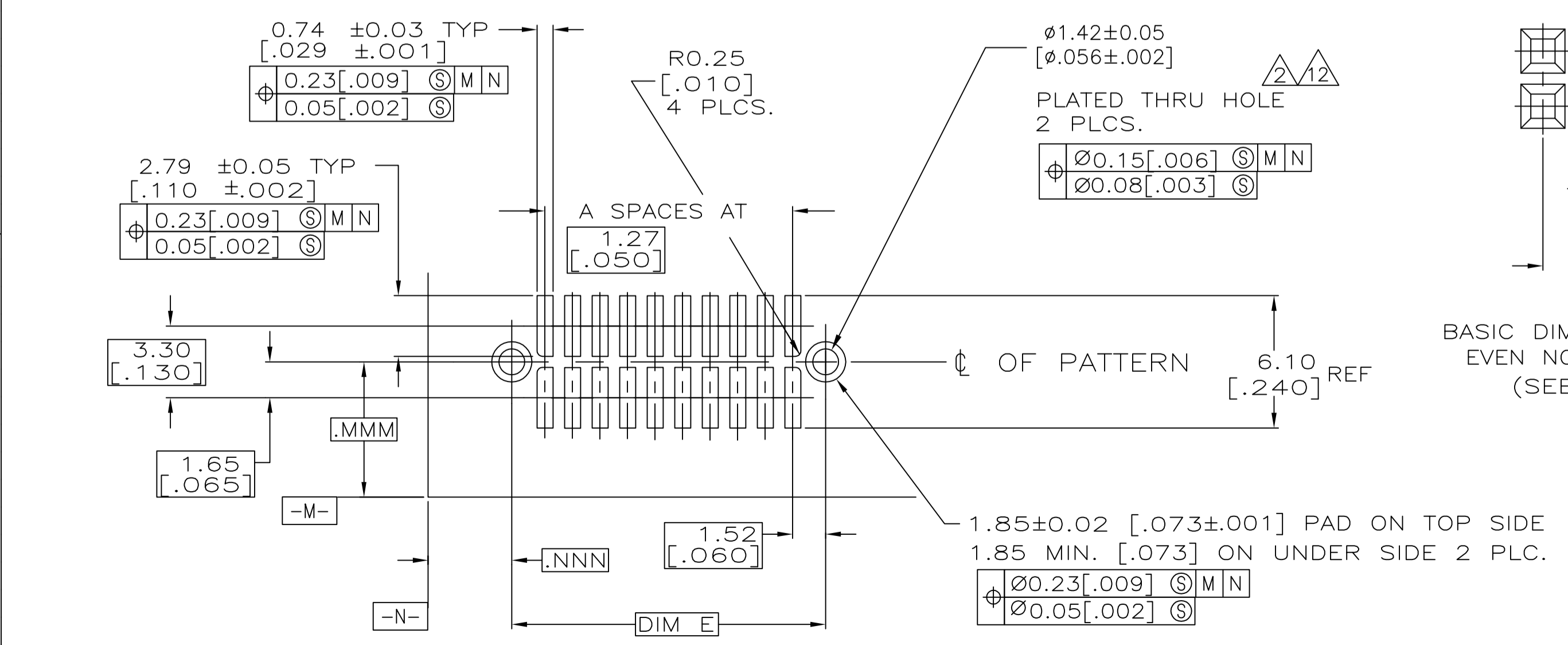
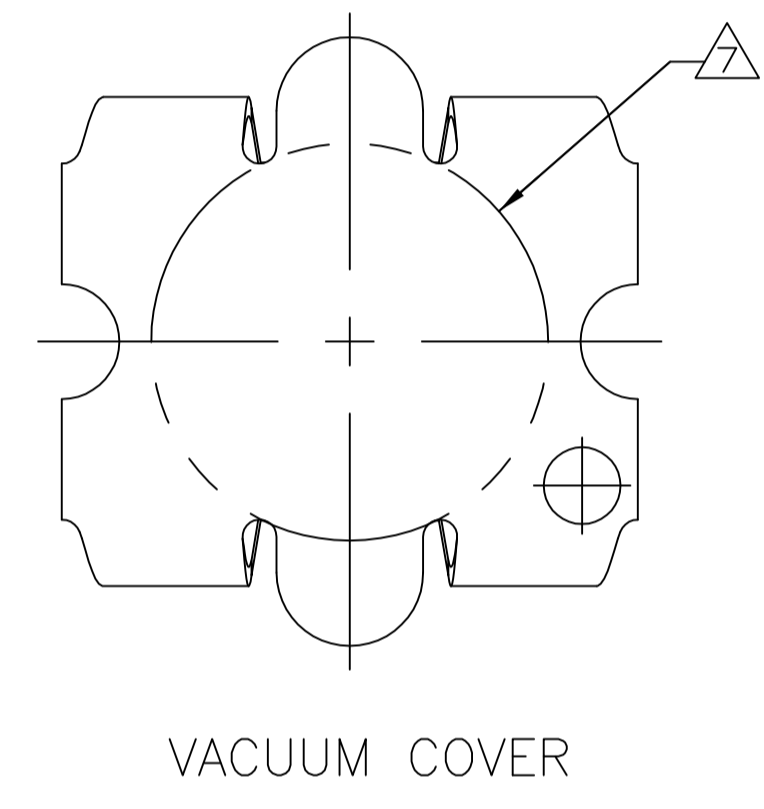
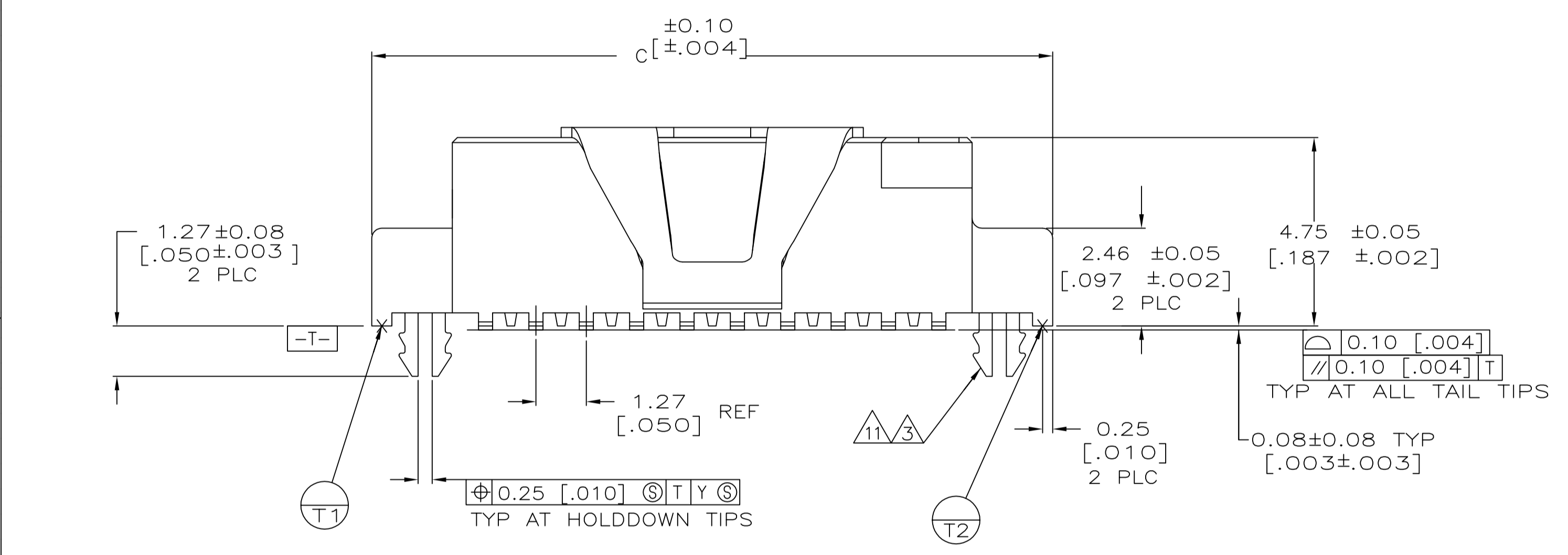
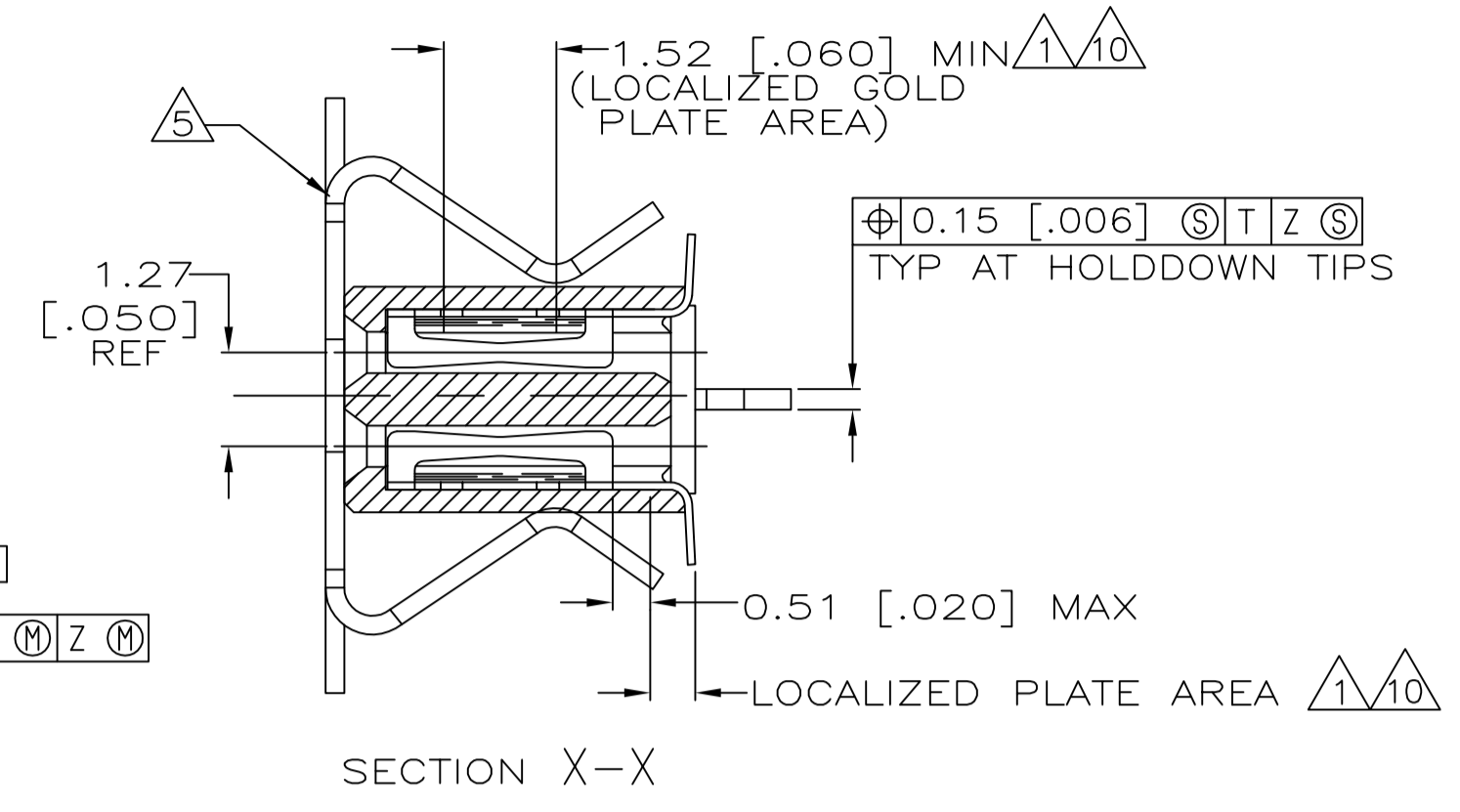
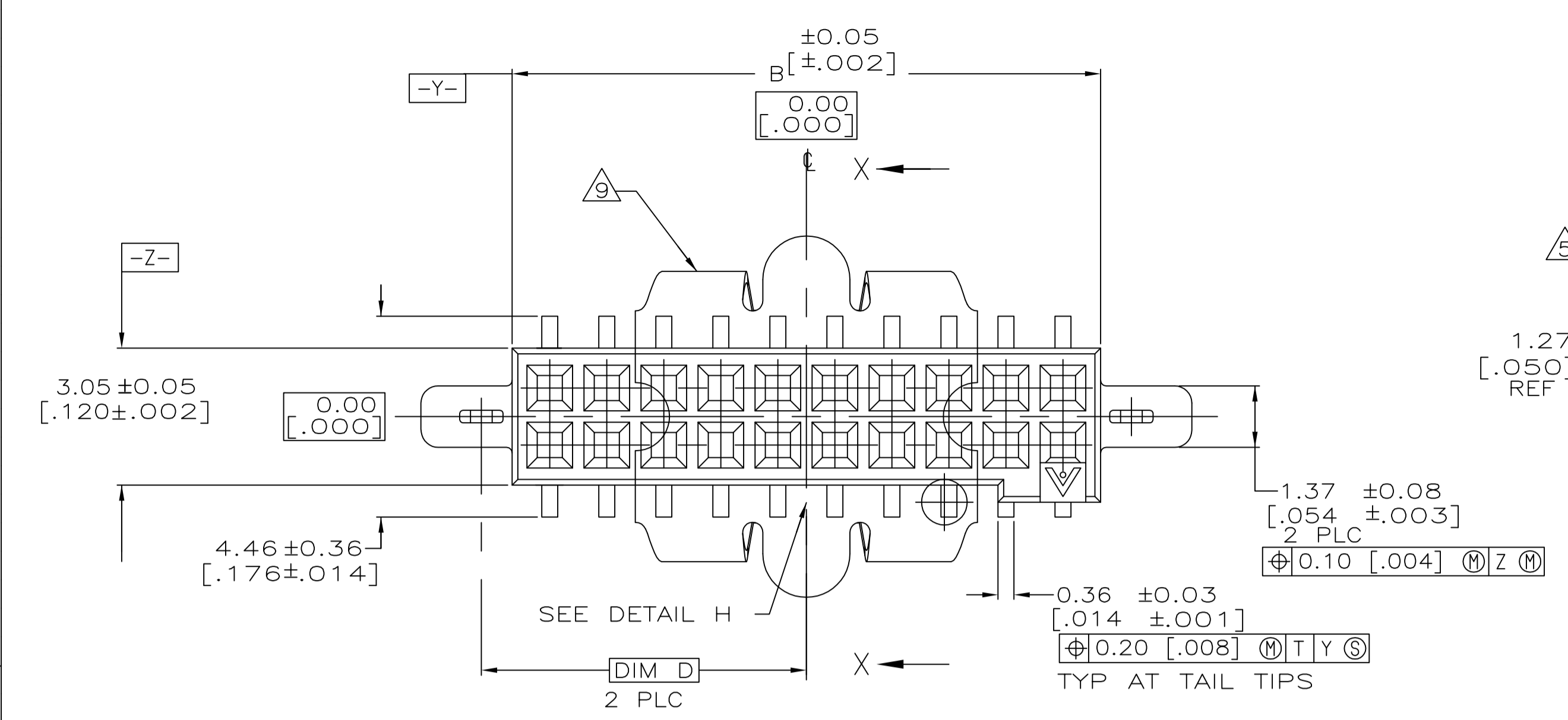

- 1 0.00076 [.000030] GOLD IN LOCALIZED PLATE AREA 0.00381 [.000150] TIN-LEAD ON SOLDER TAILS ALL OVER 0.00127 [.000050] NICKEL
- 2 USE 1.55±0.02 [.0610±.0010] DRILLED HOLE (1.55mm DRILL) FINISH TO BE TIN/LEAD OVER 0.02 [.001] MIN COPPER
- 3 PLATING: 0.0038 [.000150] TIN-LEAD OVER 0.00127 [.000050] NICKEL
- 4 IF PLANNING TO USE MORE THAN ONE MATING PAIR OF CONNECTORS TO INTERCONNECT 2 BOARDS, PLEASE REFER TO PARA. 3.3 IN THE APPLICATION SPEC, #114-7010
- 5 VACUUM COVER DESIGNED FOR 4.0 [.160] DIA NOZZLE. VACUUM COVER TO BE REMOVED AFTER SOLDERING.
- 6 PACKAGED IN EIA 481 TAPE AND REEL. SEE TABLE FOR TAPE WIDTHS.
- 7 5.2 [.205] MIN TARGET AREA FOR VACUUM PICK-UP.
- 8 HOUSING: LCP, COLOR-BLACK. CONTACT: COPPER ALLOY PER ASTM SPECIFICATION B422. HOLDDOWN: COPPER ALLOY PER ASTM SPECIFICATION B194. VACUUM COVER: ALUMINUM ALLOY PER ASTM SPECIFICATION B209.
- 9 VACUUM COVER SHOWN IN PHANTOM LINE.
- 10 0.00076 [.000030] GOLD IN LOCALIZED PLATE AREA 0.00381 [.000150] TIN ON SOLDER TAILS ALL OVER 0.00127 [.000050] NICKEL
- 11 PLATING: 0.0038 [.000150] TIN OVER 0.00127 [.000050] NICKEL
- 12 USE 1.55±0.02 [.0610±.0010] DRILLED HOLE (1.55mm DRILL) FINISH TO BE TIN OVER 0.02 [.001] MIN COPPER
- 13 OBSOLETE PARTS: OBSOLETE CIS STREAMLINING PER D.RENAUD/D.SINISI

FINISH	TAPE WIDTH	E	D	C	B	A	NO OF POS	PART NUMBER
10,11	88 mm	65.28 [2.570]	32.64 [1.285]	67.97 [2.676]	63.91 [2.516]	49	100	5-147384-9
10,11	72 mm	52.58 [2.070]	26.29 [1.035]	55.27 [2.176]	51.21 [2.016]	39	80	5-147384-8
10,11	72 mm	46.23 [1.820]	23.11 [.910]	48.92 [1.926]	44.86 [1.766]	34	70	5-147384-7
10,11	72 mm	39.88 [1.570]	19.94 [.785]	42.57 [1.676]	38.51 [1.516]	29	60	5-147384-6
10,11	56 mm	33.53 [1.320]	16.76 [.660]	36.22 [1.426]	32.16 [1.266]	24	50	5-147384-5
10,11	56 mm	27.18 [1.070]	13.59 [.535]	29.87 [1.176]	25.81 [1.016]	19	40	5-147384-4
10,11	44 mm	20.83 [.820]	10.41 [.410]	23.52 [.926]	19.46 [.766]	14	30	5-147384-3
10,11	32 mm	14.48 [.570]	7.24 [.285]	17.17 [.676]	13.11 [.516]	9	20	5-147384-2
10,11	32 mm	8.12 [.320]	4.06 [.160]	10.82 [.426]	6.75 [.266]	4	10	5-147384-1
13	SUPERSEDED BY 5-147384-9	88 mm	65.28 [2.570]	32.64 [1.285]	67.97 [2.676]	49	100	147384-9
13	SUPERSEDED BY 5-147384-8	72 mm	52.58 [2.070]	26.29 [1.035]	55.27 [2.176]	39	80	147384-8
13	SUPERSEDED BY 5-147384-7	72 mm	46.23 [1.820]	23.11 [.910]	48.92 [1.926]	34	70	147384-7
13	SUPERSEDED BY 5-147384-6	72 mm	39.88 [1.570]	19.94 [.785]	42.57 [1.676]	29	60	147384-6
13		56 mm	33.53 [1.320]	16.76 [.660]	36.22 [1.426]	24	50	147384-5
13		56 mm	27.18 [1.070]	13.59 [.535]	29.87 [1.176]	19	40	147384-4
13		44 mm	20.83 [.820]	10.41 [.410]	23.52 [.926]	14	30	147384-3
13		32 mm	14.48 [.570]	7.24 [.285]	17.17 [.676]	9	20	147384-2
13	SUPERSEDED BY 5-147384-1	32 mm	8.12 [.320]	4.06 [.160]	10.82 [.426]	4	10	147384-1

RECOMMENDED BOARD LAYOUT
SCALE: 5:1

THIS DRAWING IS A CONTROLLED DOCUMENT. DIM B HAYMAKER 28JAN00
CHK J. MOSIER 28JAN00
APVD J. MOSIER 28JAN00 NAME
PRODUCT SPEC 108-1332
APPLICATION SPEC 114-7010
SIZE CAGE CODE DRAWING NO RESTRICTED TO
A1 00779 ©=147384
CUSTOMER DRAWING SCALE 10:1 SHEET 1 OF 1 REV E

单击下面可查看定价，库存，交付和生命周期等信息

[>>TE Connectivity\(泰科\)](#)