

THIS DRAWING IS UNPUBLISHED. RELEASED FOR PUBLICATION  
 © COPYRIGHT - BY TYCO ELECTRONICS CORPORATION. ALL RIGHTS RESERVED.

LOC	DIST	REVISIONS					
		P	LTR	DESCRIPTION	DATE	DWN	APVD
G	14		R1	REV PER ECR 10-000692	13JAN10	JR	TM

<b>AMP</b> WIRE RANGE	E13288 Listed	LR7189 Certified
16-14 AWG SOLID OR STRANDED	16-14 AWG SOLID OR STRANDED	16-14 AWG SOLID OR STRANDED

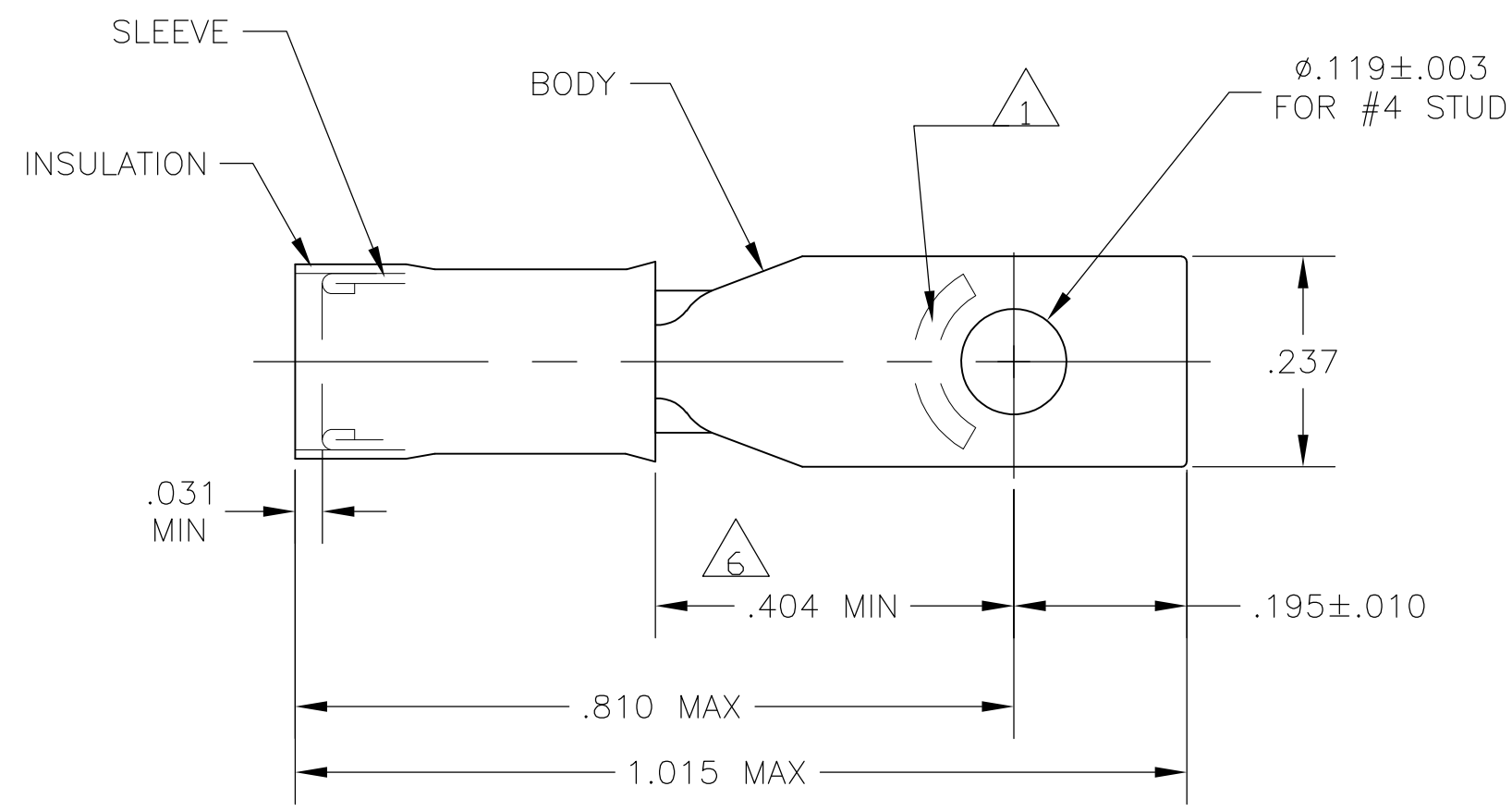

- 1 STAMP AMP 16-14\* APPROX AS SHOWN
- 2 WIRE INSULATION DIA: 105-.150
- 3 TONGUE MATERIAL THK: .031±.002
- 4 BODY & SLEEVE: CU PER ASTM B152  
INSULATION: NYLON PER ASTM D4066
- 5 BODY & SLEEVE: TIN PLATE .000100 MIN  
EXT THK PER ASTM B545  
INSULATION: COLOR - BLUE
- 6 APPLIES FROM EDGE OF METAL WIRE BARREL  
TO CENTER OF STUD HOLE.
- 7 MEETS MS17143-17, CLASS 1 & 2

2500	LOOSE PIECE	2-327964-4
QTY	PACKAGE TYPE	PART NO

<b>CUSTOMER SERVICE SYSTEMS</b>		MAX RECOMMENDED OPERATING TEMPERATURE: 170°C MAX	THIS DRAWING IS A CONTROLLED DOCUMENT.		DWN JR RUTH 12JAN10	Tyco Electronics Corporation Harrisburg, Pa 17105-3608	
FOR ADDITIONAL PRODUCT INFORMATION OR COPIES OF DRAWINGS AND TECHNICAL DOCUMENTS	PRODUCT INFORMATION CENTER 1-800-522-6752	VOLTAGE RATING: 300 V MAX	DIMENSIONS: INCHES	TOLERANCES UNLESS OTHERWISE SPECIFIED:	CHK T MICHELUTTI 13JAN10	NAME TERMINAL, RECTANGULAR TONGUE, PIDG WIRE SIZE: 16-14 AWG	
FOR APPLICATION TOOLING INFORMATION	TOOLING ASSISTANCE CENTER 1-800-722-1111	CIRCULAR MIL AREA: 1.04-2.62mm² [2,050-5,180] STRANDED OR SOLID		0 PLC ± - 1 PLC ± - 2 PLC ± - 3 PLC ± .008 4 PLC ± - ANGLES ± -	APVD T MICHELUTTI 13JAN10	APPLICATION SPEC	RESTRICTED TO
FOR ORDER ENTRY	1-800-526-5142	THIS DRAWING IS A CONTROLLED DOCUMENT FOR AMP INCORPORATED. IT IS SUBJECT TO CHANGE AND THE CONTROLLING ENGINEERING ORGANIZATION SHOULD BE CONTACTED FOR THE LATEST REVISION.	MATERIAL 	FINISH 	PRODUCT SPEC	WEIGHT -	SIZE A3
					SCALE 5:1	CAGE CODE 00779	DRAWING NO G-327964
					SHEET 1 OF 1		REV R1

单击下面可查看定价，库存，交付和生命周期等信息

[>>TE Connectivity\(泰科\)](#)