

THIS DRAWING IS UNPUBLISHED. RELEASED FOR PUBLICATION
 © COPYRIGHT - By - ALL RIGHTS RESERVED.

REVISIONS					
P	LTR	DESCRIPTION	DATE	DWN	APVD
H		REVISED PER ECO-17-010826	10AUG2017	AP	DG

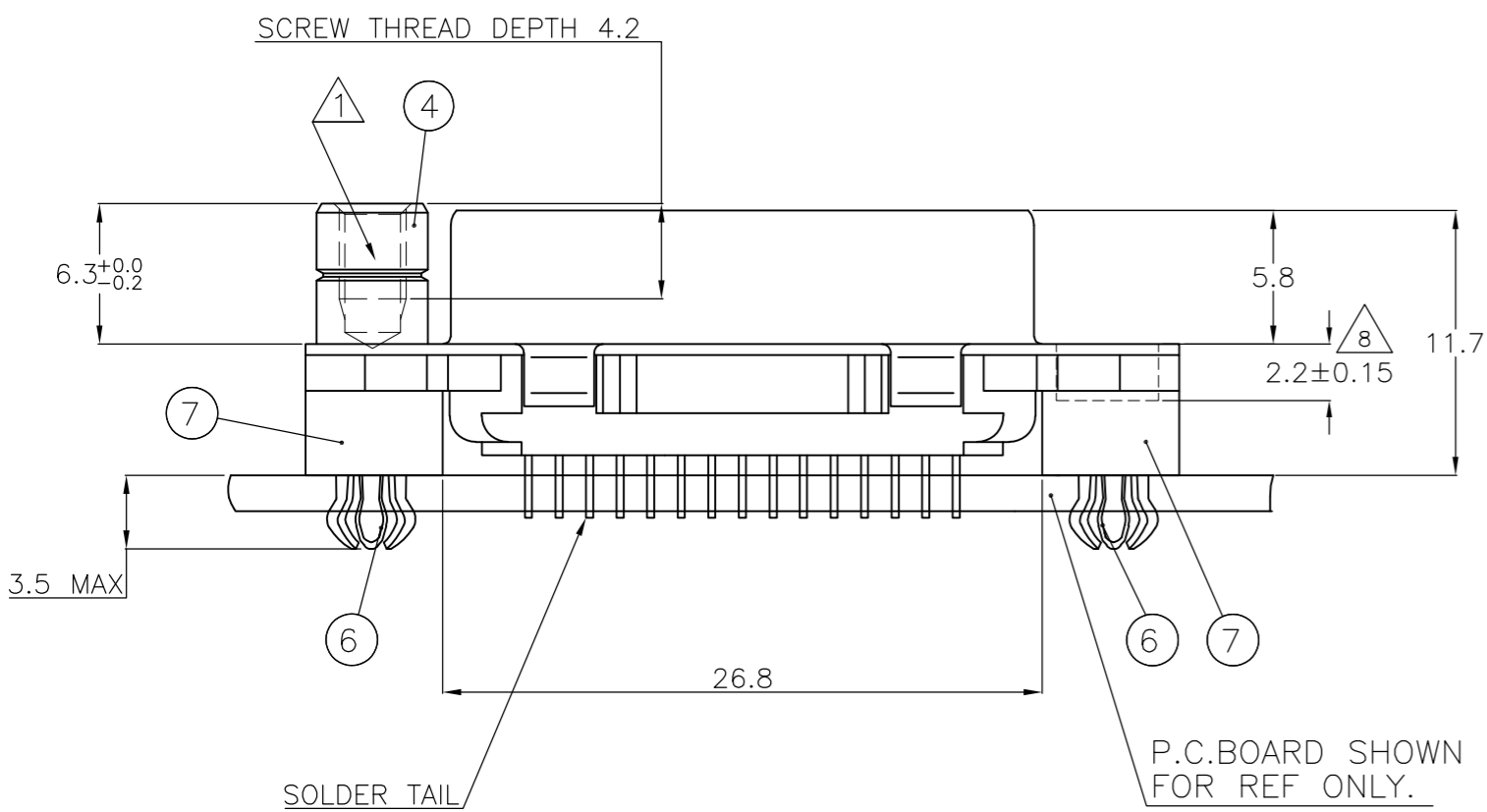
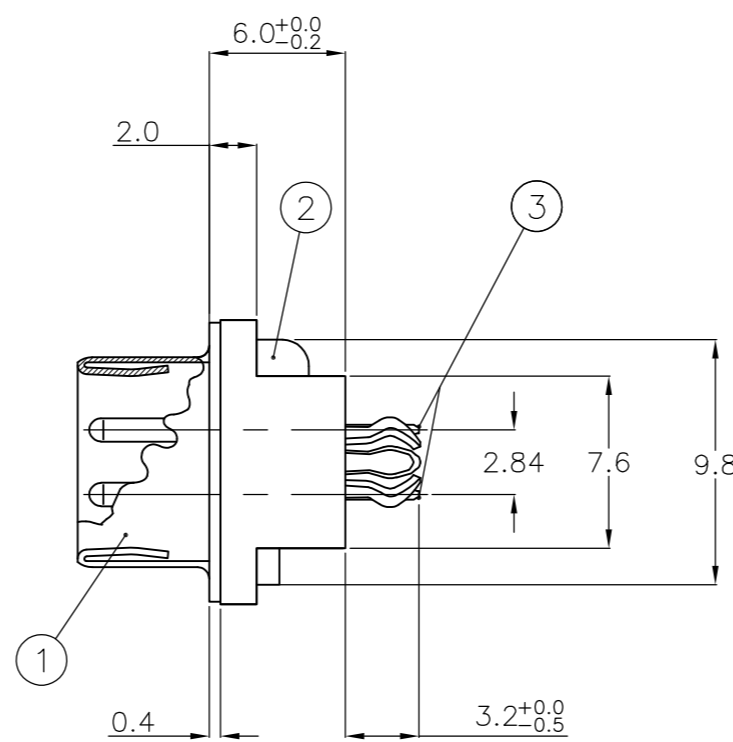
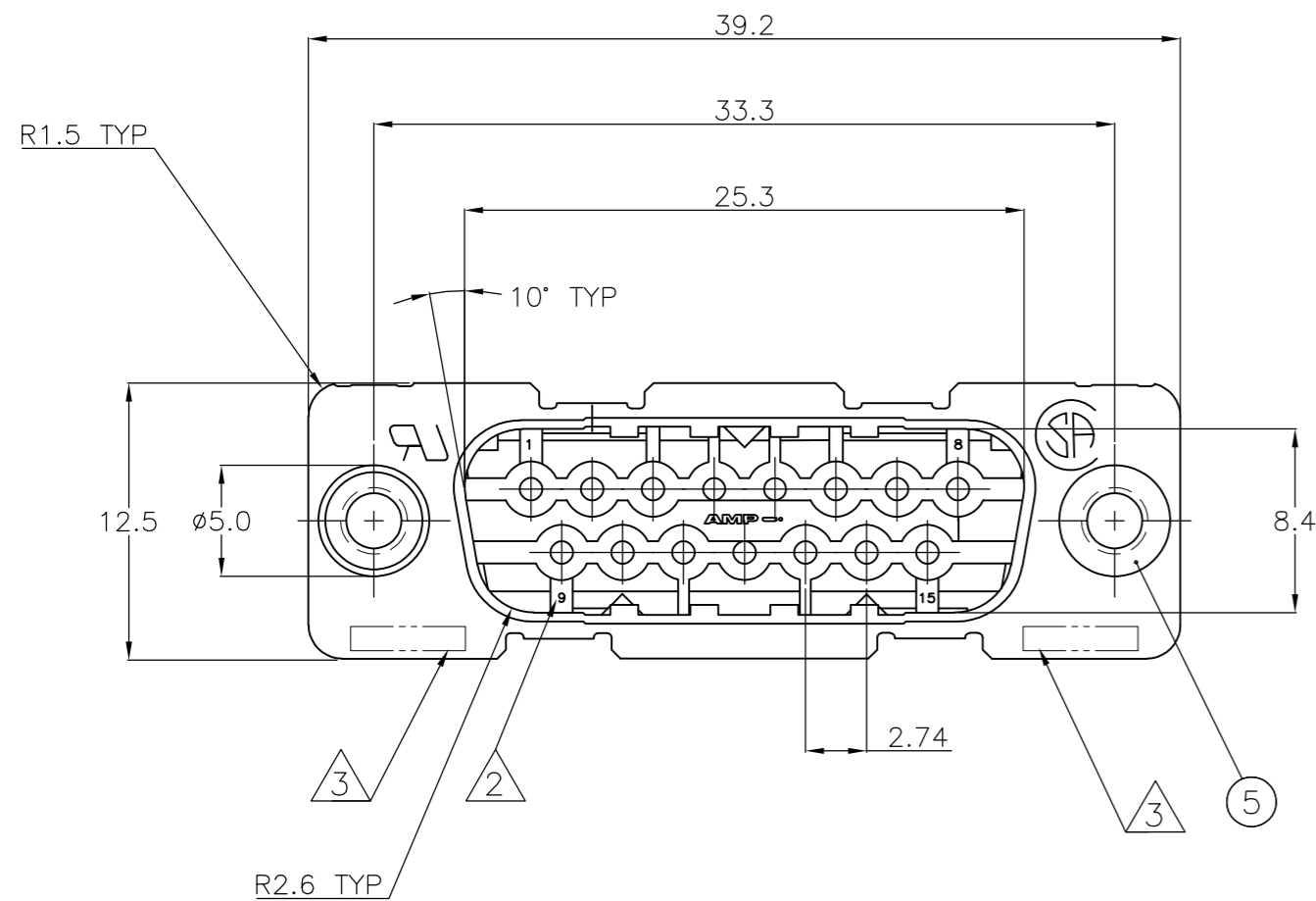

ITEM NO	DESCRIPTION OF ACCESSORY	1	2	3	4	5	6	7	8	9
5	BUSHING WITH THROUGH HOLE $\phi 3.1$									
5	BUSHING WITH THREAD 4-40 UNC		2							
5	BUSHING WITH THREAD M3			2						
4	FEMALE SCREWLOCK WITH THREAD 4-40 UNC				2					
4	FEMALE SCREWLOCK WITH THREAD M3					2				
6	BOARDLOCK		2	2	2	2				

- 1 GROOVE INDICATES VERSION WITH 4-40 UNC INNER THREAD; WITHOUT GROOVE INDICATES VERSION WITH M3 INNER THREAD.
- 2 CAVITY IDENTIFICATION AT FRONT SIDE ONLY.
- 3 PART NUMBER AND DATE CODE.
- 4. WHEN BOARDLOCKS ARE USED, CONNECTOR CAN BE USED FOR PCB THICKNESS OF 1.6 ONLY.
- 5. SHELL HAS 2x4 GROUNDING SPRINGS; PITCH IS 3.6.
- 6. AIR AND CREEPAGE DISTANCES ACCORDING TO DIN 41652.
- 7. CONTACT FINISH: GOLD FLASH OVER PALLADIUM-NICKEL PLATE OR GOLD PLATE ON THE MATING SURFACES, TIN PLATE ON THE SOLDER-TAILS, NICKEL UNDERPLATE ON THE ENTIRE CONTACT. MATING SURFACE FINISH MEETS LEVEL 2 PER DIM 41652.
- 8 4-40/M3 THREAD DEPTH

RECOMMENDED P.C. BOARD HOLE-LAYOUT

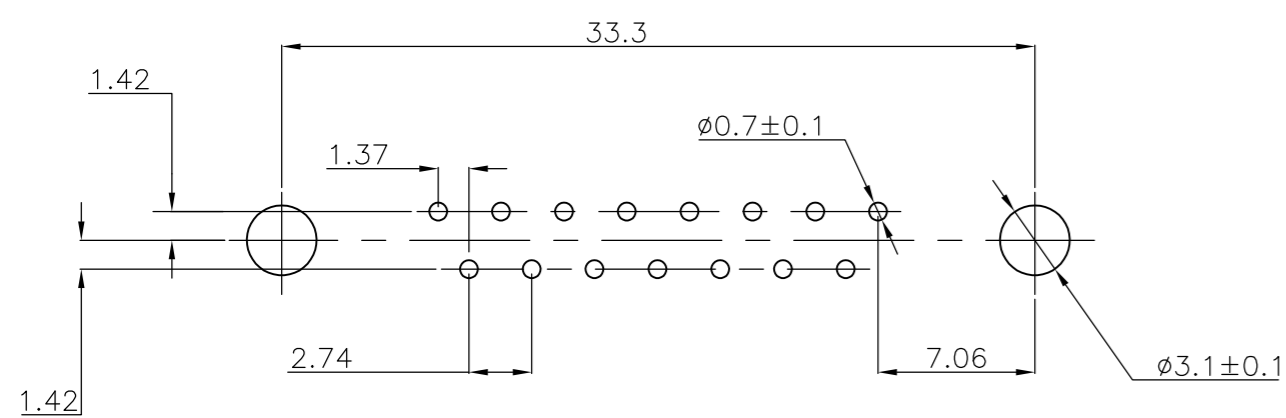

ITEM NO/MATERIAL:

- 1 SHELL : BRIGHT TIN PLATED STEEL
- 2 HOUSING : GLASS FILLED POLYESTER, COLOR : BLACK
- 3 CONTACTS : PHOSPHOR BRONZE (PLATING : SEE NOTES)
- 4 FEMALE SCREWLOCK : TIN PLATED STEEL (INNER THREAD 4-40 UNC OR M3)
- 5 BUSHING : TIN PLATED STEEL (INNER THREAD 4-40 UNC OR M3 OR $\phi 3.1$ THROUGH HOLE)
- 6 BOARDLOCK : TIN PLATED PHOSPHOR BRONZE
- 7 STAND-OFF : GLASS FILLED NYLON COLOR : BLACK

THIS DRAWING IS A CONTROLLED DOCUMENT. DIMENSIONING AND TOLERANCING PER ASME Y14.5M-2009		DWN J.V. LIEMPT 03JUL97		
DIMENSIONS: mm		CHK C. SOUISA 09SEP97		
TOLERANCES UNLESS OTHERWISE SPECIFIED:		APVD W. SOOMERS 09SEP97	NAME	
0 PLC ± -	1 PLC ± 0.3	PRODUCT SPEC	HDP-20 SIZE 2 VERTICAL+ PLUG HEADER WITH SOLDER CONTACTS	
2 PLC ± 0.15	3 PLC ± -	APPLICATION SPEC	SIZE A2	CAGE CODE 00779
4 PLC ± -	ANGLES ± -	WEIGHT 0	DRAWING NO C=338310	RESTRICTED TO -
MATERIAL -	FINISH -	CUSTOMER DRAWING	SCALE NTS	SHEET 1 OF 1

单击下面可查看定价，库存，交付和生命周期等信息

[>>TE Connectivity\(泰科\)](#)

[>>点击查看相关商品](#)