

P	LTR	DESCRIPTION	DATE	DWN	APVD
P		REVISED PER ECO-14-015277	09FEB2015	NK	DR
P1		REVISED PER ECO-17-008114	07JUN2018	RS	DR

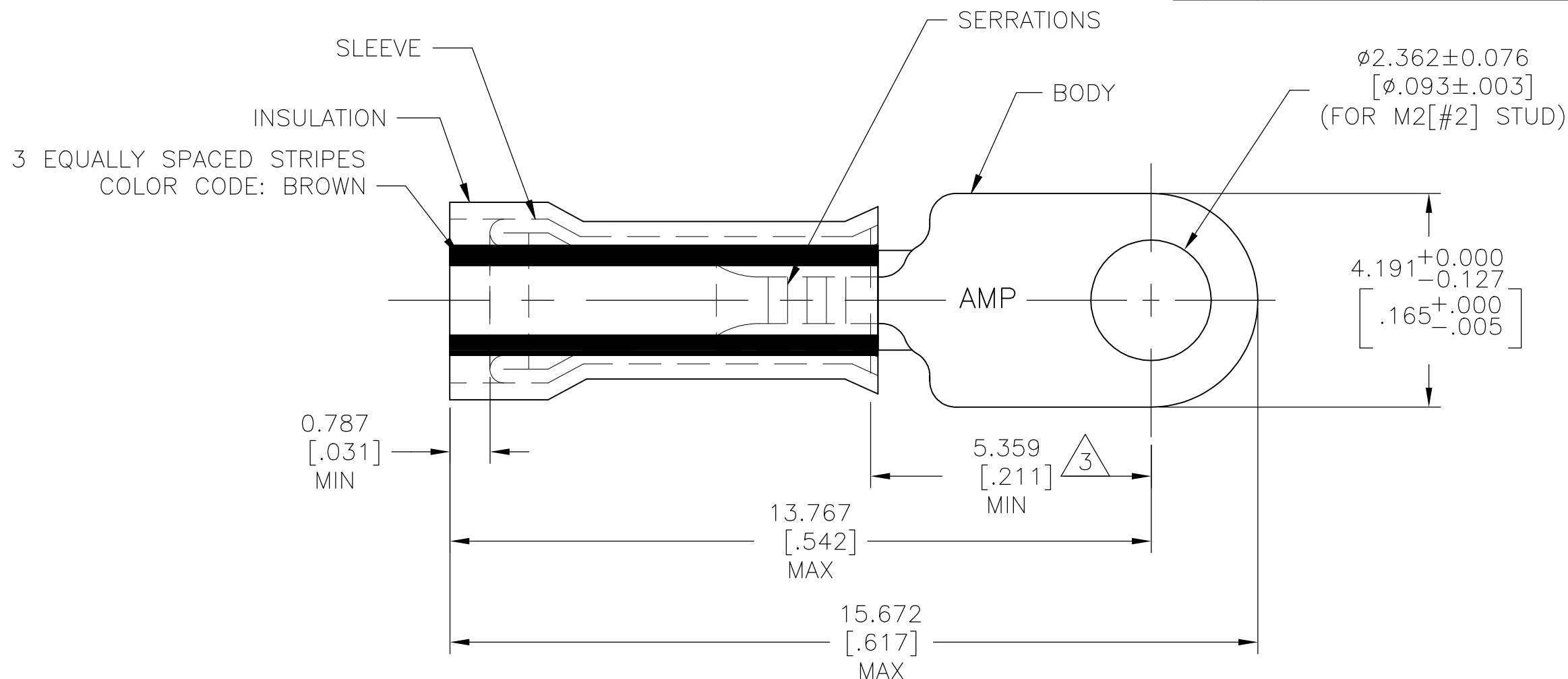

1 FOR 1.270[.050] TO 2.083[.082] WIRE INS DIA.

2 TONGUE MATERIAL THK 0.457 ± 0.051 [$.018 \pm .002$].

APPLIES FROM EDGE OF METAL WIRE BARREL TO CENTER OF STUD HOLE.

1000	LOOSE PIECE	BODY & SLEEVE: COPPER ASTM-B152 TIN PL ASTM-B545 INSULATION: NYLON COLOR: YELLOW	321620
QTY	DESCRIPTION	MATERIAL & FINISH	PART NO

THIS DRAWING IS A CONTROLLED DOCUMENT.		DWN RAGHAVENDRA 08MAR10	TE Connectivity Ltd.													
DIMENSIONS: mm [INCHES]		CHK JEFF RUTH 08MAR10														
TOLERANCES UNLESS OTHERWISE SPECIFIED:		APVD TOM MICHIELUTTI 08MAR10	NAME TERMINAL NYLON - PIDG - RING TONGUE WIRE SIZE: 26-22 AWG													
<table border="0"> <tr> <td>0 PLC</td> <td>± -</td> </tr> <tr> <td>1 PLC</td> <td>± -</td> </tr> <tr> <td>2 PLC</td> <td>± -</td> </tr> <tr> <td>3 PLC</td> <td>± 0.127[.005]</td> </tr> <tr> <td>4 PLC</td> <td>± -</td> </tr> <tr> <td>ANGLES</td> <td>± .5°</td> </tr> </table>		0 PLC	± -	1 PLC	± -	2 PLC	± -	3 PLC	± 0.127[.005]	4 PLC	± -	ANGLES	± .5°	PRODUCT SPEC -	RESTRICTED TO -	
0 PLC	± -															
1 PLC	± -															
2 PLC	± -															
3 PLC	± 0.127[.005]															
4 PLC	± -															
ANGLES	± .5°															
MATERIAL SEE TABLE		APPLICATION SPEC 114-2157	SIZE A3	CAGE CODE 00779												
FINISH SEE TABLE		WEIGHT -	DRAWING NO C-321620	REV P1												
CUSTOMER DRAWING			SCALE 10:1	SHEET 1 OF 1												

单击下面可查看定价，库存，交付和生命周期等信息

[>>TE Connectivity\(泰科\)](#)