

REVISONS		DATE	BY	APPV
AA1	REVISED PER ECO-08-017295	06NOV08	HMR	NE
AA2	REVISED PER ECO-09-020689	31AUG09	KK	AEG

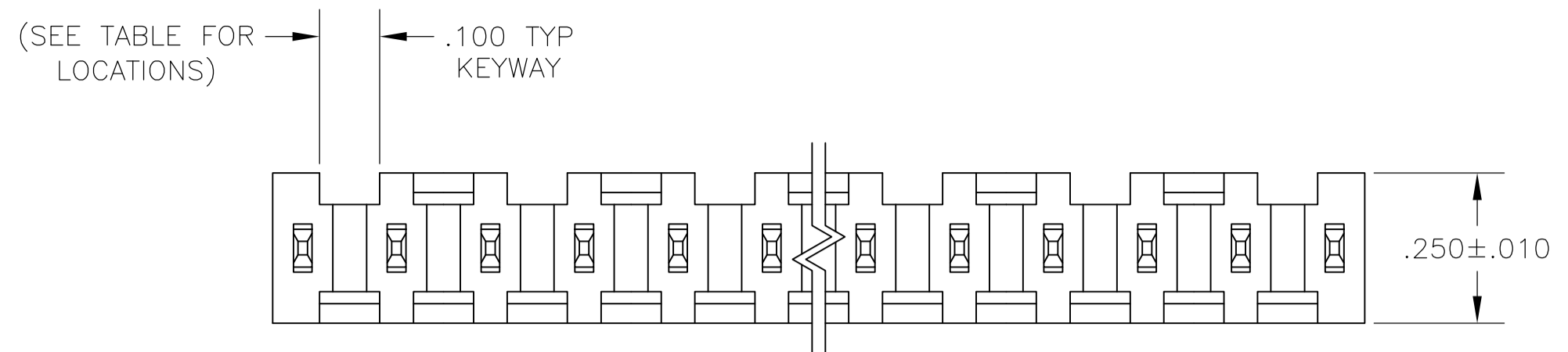

- 1 THESE SURFACES WILL NOT BE PLATED
- 2 THE NOTED DIMENSIONS APPLY AT THE INTERSECTION OF THE POST AND THE HOUSING
- 3 FINISH POSTS: .000100-.000200 TIN-LEAD OVER .000030 MIN NICKEL
- 4 FINISH POSTS: .000100-.000200 MATTE TIN OVER .000030 MIN NICKEL
- 5 OBSOLETE PARTS: OBSOLETE CIS STREAMLINING PER D.RENAUD/D.SINISI

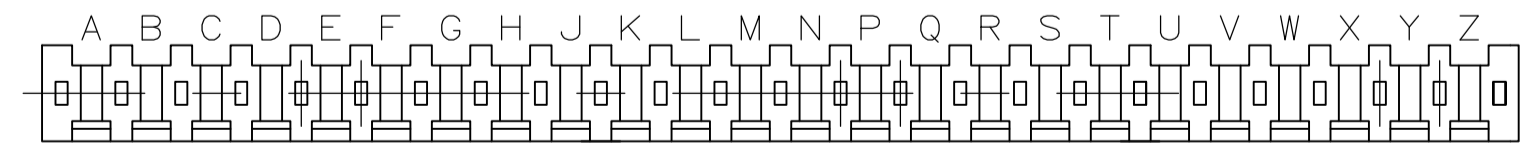
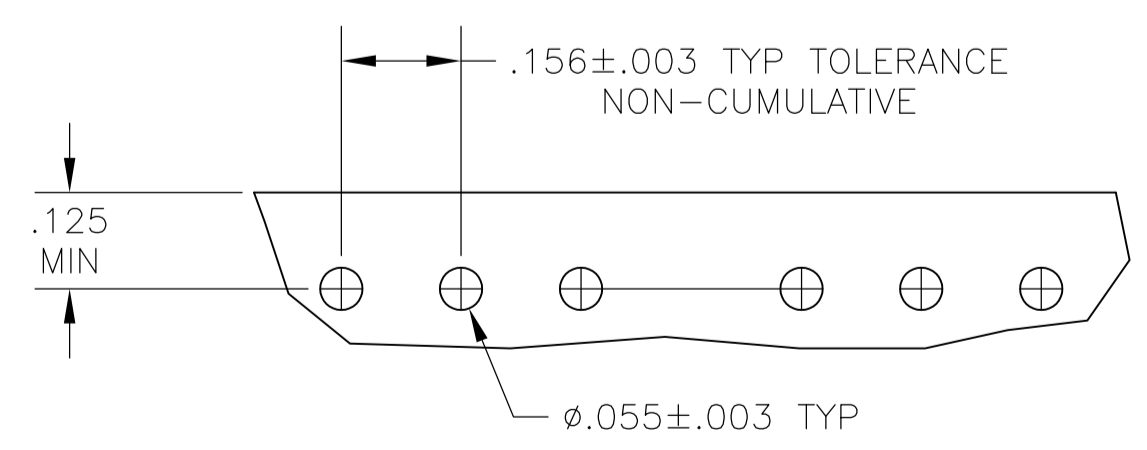
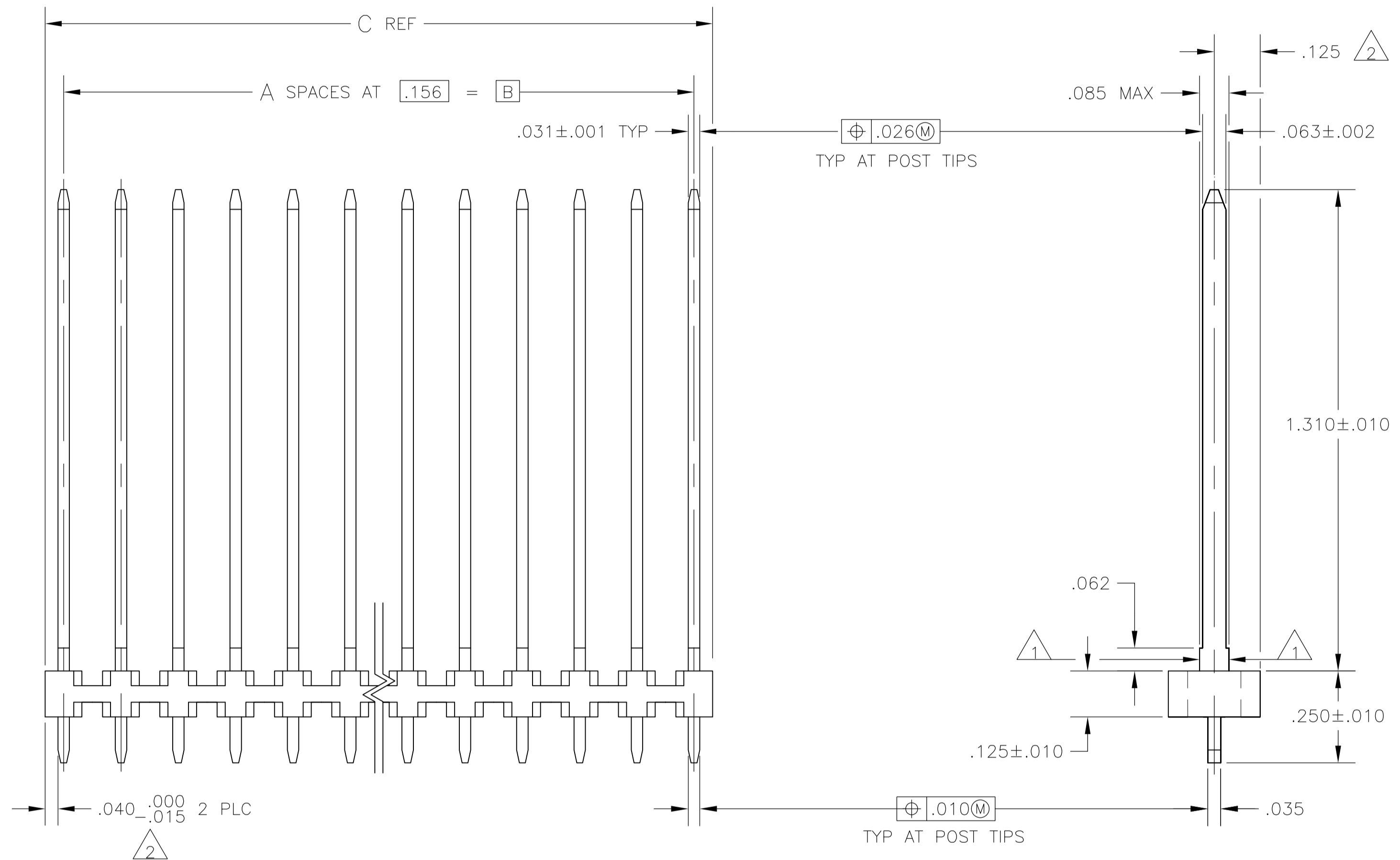

KEYWAY LOCATIONS (REF-SEE TABLE)
 (MATING LENGTH OF POST ON NEAR SIDE)
 SCALE 2:1

FINISH	KEYWAY LOCATIONS	NO OF KEYWAY	C	B	A	NO OF POSN	ASSEMBLY PART NUMBER
4	A,C,E,H,K,M,Q,S,U,W,Y	11	3.855	3.744	24	25	7-85840-5
4	A,C,E,G,J,L,N,Q,S,U,W,Y	12	3.699	3.588	23	24	7-85840-4
4	A,D,G,K,N,R,U,X	8	3.543	3.432	22	23	7-85840-3
4	A,C,E,G,J,L,N,Q,S,U,W	11	3.387	3.276	21	22	7-85840-2
4	A,D,G,K,N,R,U	7	3.231	3.120	20	21	7-85840-1
4	A,C,E,G,J,L,N,Q,S,U	10	3.075	2.964	19	20	7-85840-0
4	B,D,F,J,L,N,Q,S	8	2.919	2.808	18	19	6-85840-9
4	A,D,F,J,M,P,S	7	2.763	2.652	17	18	6-85840-8
4	A,D,G,K,N,R	6	2.607	2.496	16	17	6-85840-7
4	A,C,E,G,J,L,N,Q	8	2.451	2.340	15	16	6-85840-6
4	A,D,G,K,N	5	2.295	2.184	14	15	6-85840-5
4	A,C,E,G,J,L,N	7	2.139	2.028	13	14	6-85840-4
4	A,D,J,M	4	1.983	1.872	12	13	6-85840-3
4	A,C,E,G,J,L	6	1.827	1.716	11	12	6-85840-2
4	A,D,G,K	4	1.671	1.560	10	11	6-85840-1
4	A,C,E,G,J	5	1.515	1.404	9	10	6-85840-0
4	A,D,G	3	1.359	1.248	8	9	5-85840-9
4	A,C,E,G	4	1.203	1.092	7	8	5-85840-8
4	A,C,E	3	1.047	.936	6	7	5-85840-7
4	A,D	2	.891	.780	5	6	5-85840-6
4	A,C	2	.735	.624	4	5	5-85840-5
4	A	1	.579	.468	3	4	5-85840-4
4	A	1	.423	.312	2	3	5-85840-3
4	A	1	.267	.156	1	2	5-85840-2
4	-	0	.111	-	1	1	5-85840-1
4	-	0	5.415	5.304	34	35	3-85840-5
4	-	0	5.259	5.148	33	34	3-85840-4
4	-	0	5.103	4.992	32	33	3-85840-3
4	-	0	4.947	4.836	31	32	3-85840-2
4	-	0	4.791	4.680	30	31	3-85840-1
4	-	0	4.635	4.524	29	30	3-85840-0
4	-	0	4.479	4.368	28	29	2-85840-9
4	-	0	4.323	4.212	27	28	2-85840-8
4	-	0	4.167	4.056	26	27	2-85840-7
4	-	0	4.011	3.900	25	26	2-85840-6
3	A,C,E,H,K,M,Q,S,U,W,Y	11	3.855	3.744	24	25	2-85840-5
3	A,C,E,G,J,L,N,Q,S,U,W,Y	12	3.699	3.588	23	24	2-85840-4
3	A,D,G,K,N,R,U,X	8	3.543	3.432	22	23	2-85840-3
3	A,C,E,G,J,L,N,Q,S,U,W	11	3.387	3.276	21	22	2-85840-2
3	A,D,G,K,N,R,U	7	3.231	3.120	20	21	2-85840-1
3	A,C,E,G,J,L,N,Q,S,U	10	3.075	2.964	19	20	2-85840-0
3	B,D,F,J,L,N,Q,S	8	2.919	2.808	18	19	1-85840-9
3	A,D,F,J,M,P,S	7	2.763	2.652	17	18	1-85840-8
3	A,D,G,K,N,R	6	2.607	2.496	16	17	1-85840-7
3	A,C,E,G,J,L,N,Q	8	2.451	2.340	15	16	1-85840-6
3	A,D,G,K,N	5	2.295	2.184	14	15	1-85840-5
3	A,C,E,G,J,L,N	7	2.139	2.028	13	14	1-85840-4
3	A,D,J,M	4	1.983	1.872	12	13	1-85840-3
3	A,C,E,G,J,L	6	1.827	1.716	11	12	1-85840-2
3	A,D,G,K	4	1.671	1.560	10	11	1-85840-1
3	A,C,E,G,J	5	1.515	1.404	9	10	1-85840-0
3	A,D,G	3	1.359	1.248	8	9	85840-9
3	A,C,E,G	4	1.203	1.092	7	8	85840-8
3	A,C,E	3	1.047	.936	6	7	85840-7
3	A,D	2	.891	.780	5	6	85840-6
3	A,C	2	.735	.624	4	5	85840-5
3	A	1	.579	.468	3	4	85840-4
3	A	1	.423	.312	2	3	85840-3
3	A	1	.267	.156	1	2	85840-2
3	-	0	.111	-	1	1	85840-1
5	A,C,E,H,K,M,Q,S,U,W,Y	11	3.855	3.744	24	25	2-85840-5
5	A,C,E,G,J,L,N,Q,S,U,W,Y	12	3.699	3.588	23	24	2-85840-4
5	A,D,G,K,N,R,U,X	8	3.543	3.432	22	23	2-85840-3
5	A,C,E,G,J,L,N,Q,S,U,W	11	3.387	3.276	21	22	2-85840-2
5	A,D,G,K,N,R,U	7	3.231	3.120	20	21	2-85840-1
5	A,C,E,G,J,L,N,Q,S,U	10	3.075	2.964	19	20	2-85840-0
5	B,D,F,J,L,N,Q,S	8	2.919	2.808	18	19	1-85840-9
5	A,D,F,J,M,P,S	7	2.763	2.652	17	18	1-85840-8
5	A,D,G,K,N,R	6	2.607	2.496	16	17	1-85840-7
5	A,C,E,G,J,L,N,Q	8	2.451	2.340	15	16	1-85840-6
5	A,D,G,K,N	5	2.295	2.184	14	15	1-85840-5
5	A,C,E,G,J,L,N	7	2.139	2.028	13	14	1-85840-4
5	A,D,J,M	4	1.983	1.872	12	13	1-85840-3
5	A,C,E,G,J,L	6	1.827	1.716	11	12	1-85840-2
5	A,D,G,K	4	1.671	1.560	10	11	1-85840-1
5	A,C,E,G,J	5	1.515	1.404	9	10	1-85840-0
5	A,D,G	3	1.359	1.248	8	9	85840-9
5	A,C,E,G	4	1.203	1.092	7	8	85840-8
5	A,C,E	3	1.047	.936	6	7	85840-7
5	A,D	2	.891	.780	5	6	85840-6
5	A,C	2	.735	.624	4	5	85840-5
5	A	1	.579	.468	3	4	85840-4
5	A	1	.423	.312	2	3	85840-3
5	A	1	.267	.156	1	2	85840-2
5	-	0	.111	-	1	1	85840-1

OBSOLETE

THIS DRAWING IS A CONTROLLED DOCUMENT.

DIMENSIONS: INCHES
 TOLERANCES UNLESS OTHERWISE SPECIFIED:
 0 PLC ± -
 1 PLC ± -
 2 PLC ± -
 3 PLC ± .005
 4 PLC ± -
 ANGLES ± -
 MATERIAL: HOUSING - FLAME RETARDANT THERMOPLASTIC. COLOR - BLACK. POSTS - BRASS. FINISH: SEE TABLE.

DRAWN: L. A. MAYER 29APR87
 CHK: P. de Jong 19MAY87
 APVD: P. de Jong 19MAY87
 NAME: P. de Jong
 PRODUCT SPEC: 108-25016
 APPLICATION SPEC:

Tyco Electronics Corporation
 Harrisburg, PA 17105-3608
 Tyco Electronics
 HEADER ASSEMBLY, MOD I, VERTICAL, SINGLE ROW, .156 Q.

SIZE: A1
 CAGE CODE: 00779
 DRAWING NO: 85840
 WEIGHT: -
 CUSTOMER DRAWING:

RESTRICTED TO: -
 SCALE: 4:1
 SHEET: 1 of 1
 REV: AA2

单击下面可查看定价，库存，交付和生命周期等信息

[>>TE Connectivity\(泰科\)](#)