

THIS DRAWING IS UNPUBLISHED. RELEASED FOR PUBLICATION  
 © COPYRIGHT - By - ALL RIGHTS RESERVED.

LOC	DIST	REVISIONS			
P	LTR	DESCRIPTION	DATE	DWN	APVD
GP	00	B	REVISED PER ECO-11-012231	12SEP2011	CJV CWR

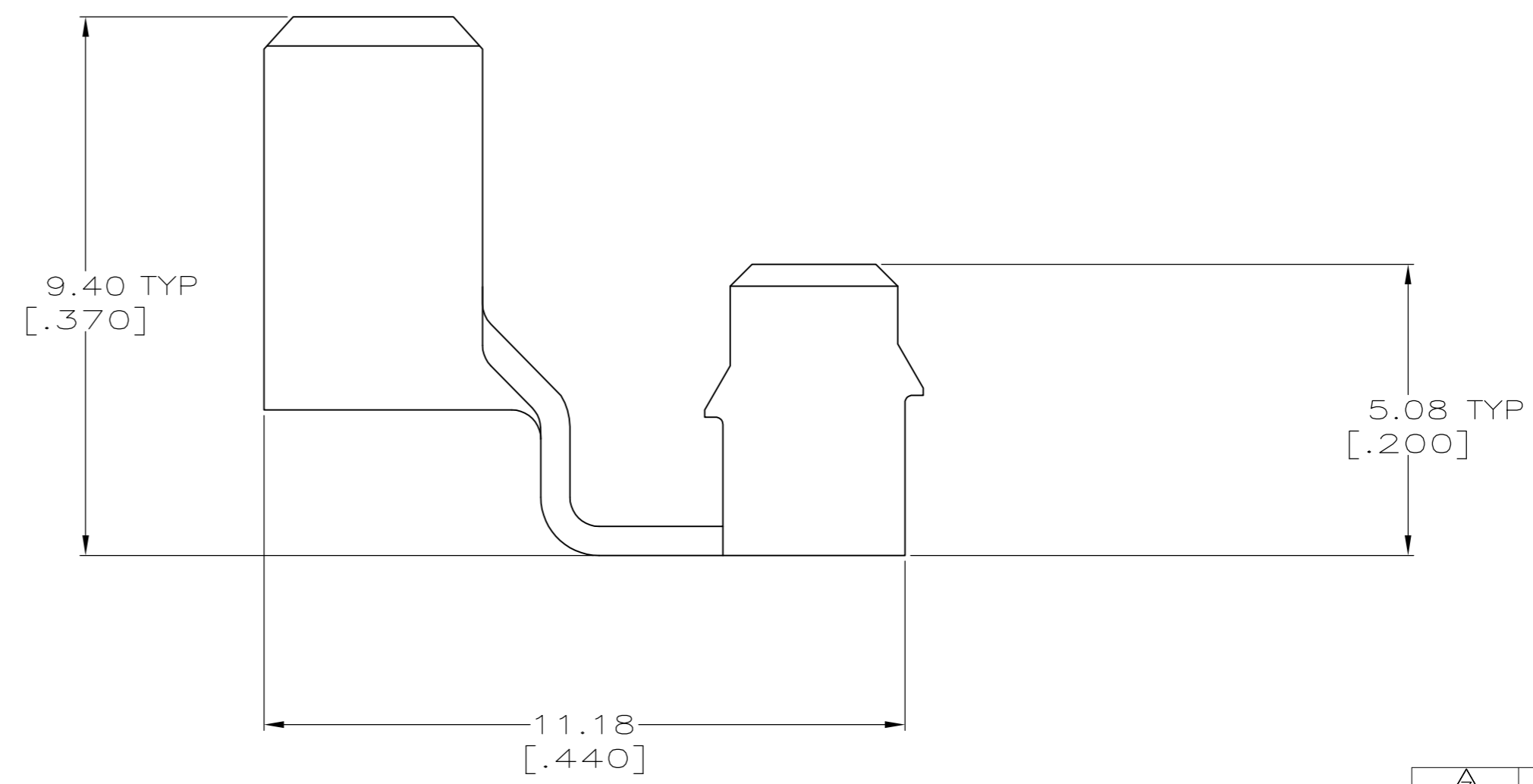
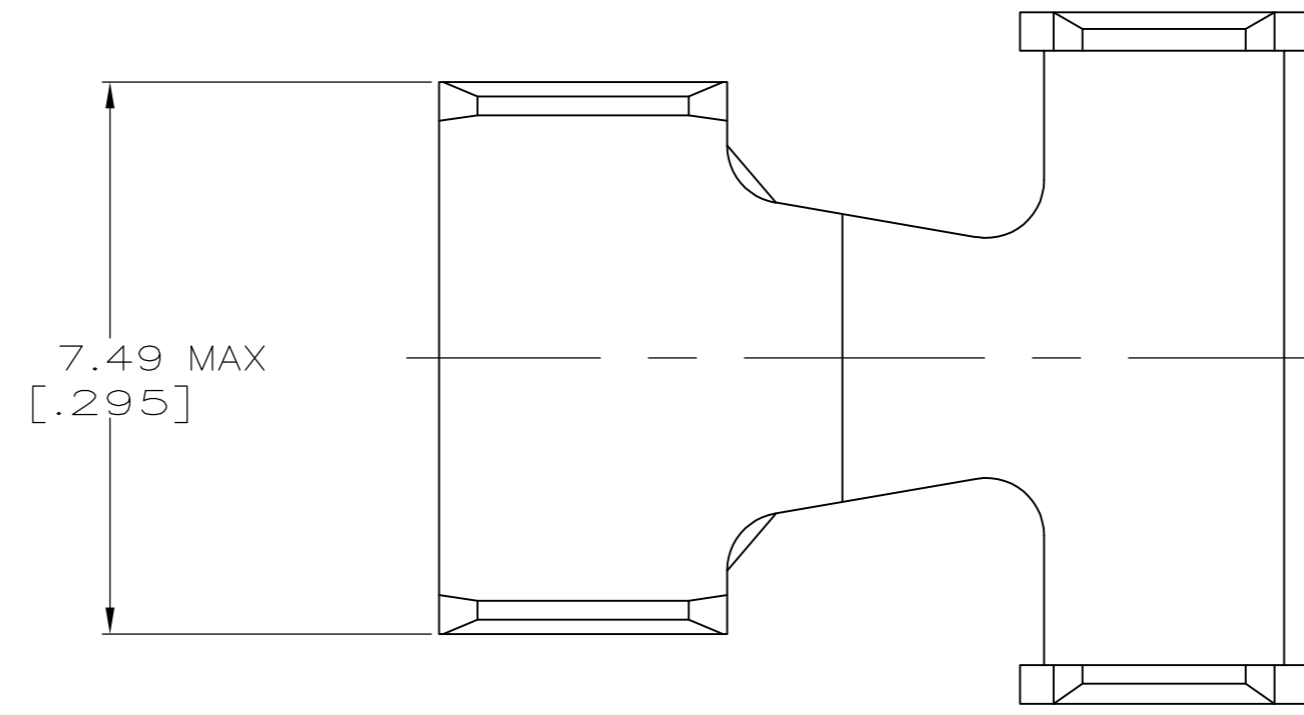
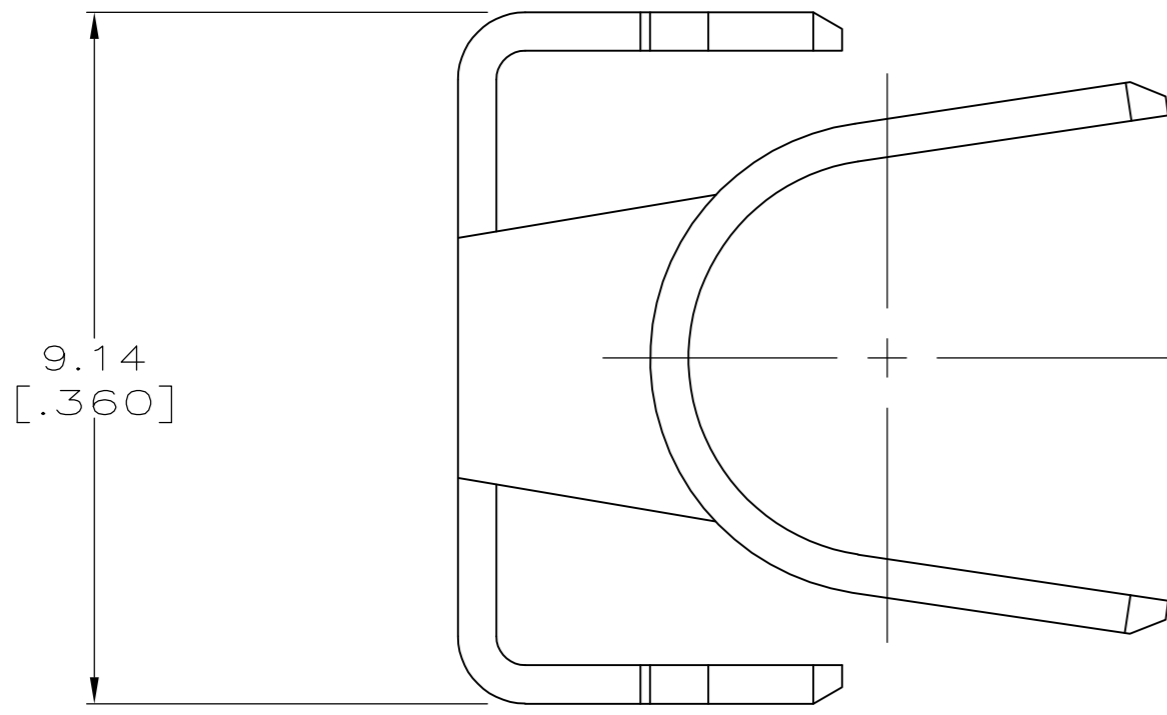

- ① 0.76μm[.000030] MIN TIN-LEAD OVER 1.27μm[.000050] MIN NICKEL.
- ② CARTRIDGE BRASS STRIP, B326 UNS 26000, 0.51[.020] THK.
- ③ 0.76μm[.000030] MIN TIN OVER 1.27μm[.000050] MIN NICKEL.

OBSOLETE	③	943072-3
	①	943072-2
FINISH		PART NUMBER

THIS DRAWING IS A CONTROLLED DOCUMENT.		DWN	M.BINNER	01/25/95	 TE Connectivity	
DIMENSIONS:		CHK	R.STONE	01/26/95		
mm [INCHES]		APVD	R.BAER	01/26/95		
TOLERANCES UNLESS OTHERWISE SPECIFIED:		PRODUCT SPEC				
0 PLC	± -	APPLICATION SPEC			NAME	STRAIN RELIEF, SDL
1 PLC	± -				SIZE	A2
2 PLC	± 0.13 [.005]				CAGE CODE	00779
3 PLC	± -				DRAWING NO	C=943072
4 PLC	± -				RESTRICTED TO	-
ANGLES	± -				SCALE	10:1
MATERIAL	②	FINISH	SEE TABLE		SHEET	1 of 1
		WEIGHT	-		REV	B
		CUSTOMER DRAWING				

单击下面可查看定价，库存，交付和生命周期等信息

[>>TE Connectivity\(泰科\)](#)