

REVISIONS				
P	LTR	DESCRIPTION	DATE	OWN
G		REV PER ECO 17-007893	6-5-17	CT DM

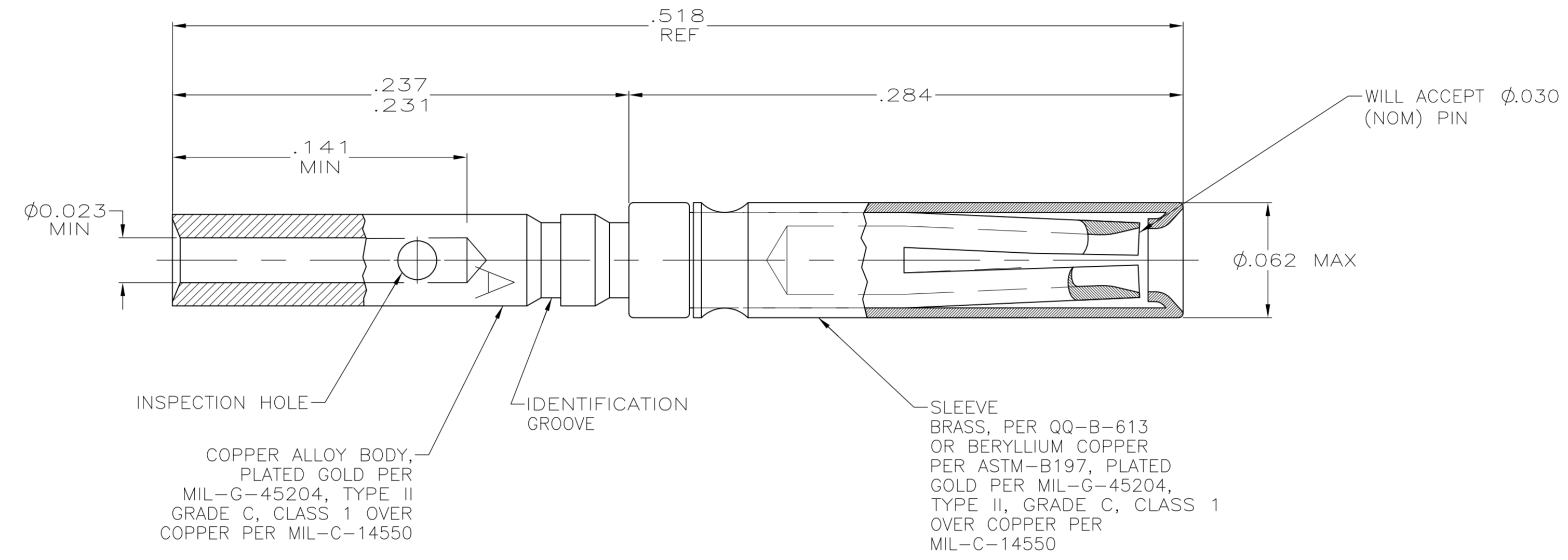

PRESS FIT HOOD CONFIGURATION

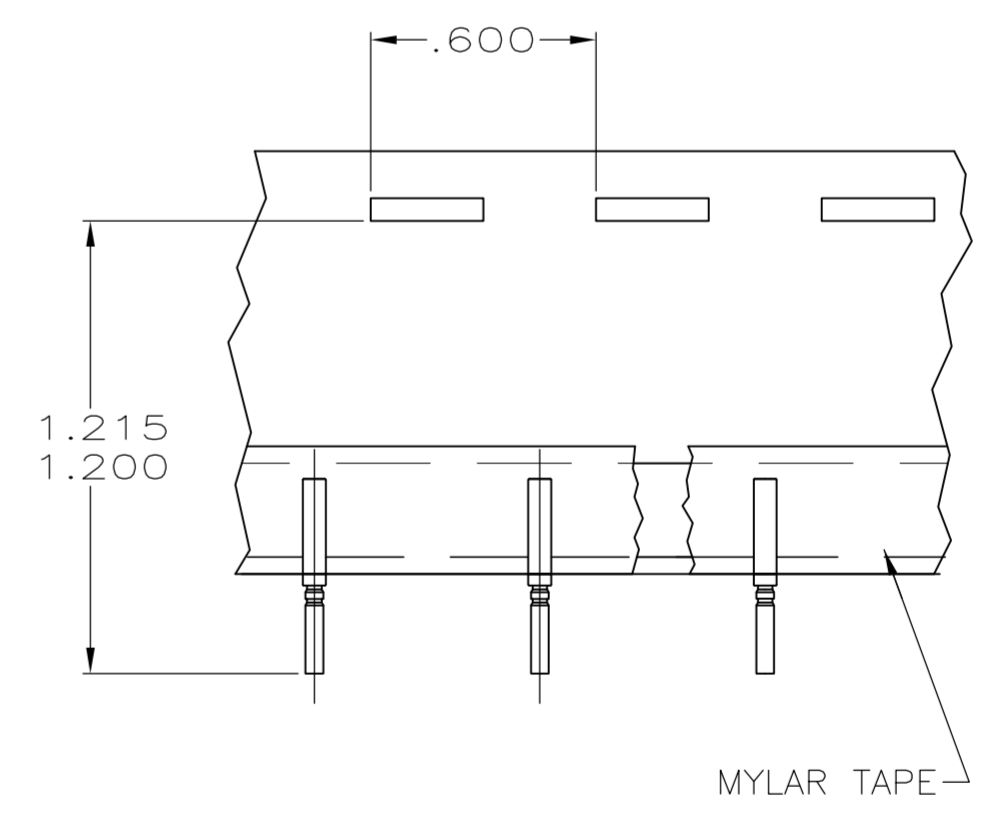

TAPE MOUNTED -2 ONLY

1. WIRE BARREL WILL ACCEPT #26 - 28 AWG WIRE.
 2. CRIMPING TOOL - USE HANDTOOL M22520/2-01 (AMP P/N 601996-1) WITH POSITIONER M22520/2-06 (AMP P/N 601966-4) SEE AMP INSTRUCTION SHEET, IS7516, FOR CRIMPING INSTRUCTIONS.
 3. CONTACT CONFORMS TO MIL-C-24308/57-354, EXCEPT NO COLOR CODE AND INSIDE DIAMETER ON CRIMP BARREL IS SMALLER TO ACCEPT #26 - 28 AWG WIRE.
 4. INSERTION/EXTRACTION TOOL AMP P/N 91067-1.
 5. USE AMP - TAPEMATIC STRIPPER/CRIMPER MACHINE NUMBER 299406-7 WITH FUNNEL NUMBER 125905-2.
 6. SLEEVE MAY BE CRIMPED OR DIMPLED ONTO CONTACT BODY.
- RESTRICTED TO SPACE SYSTEMS LORAL.

REMARKS	DESCRIPTION	PART NO.
7	AS SHOWN	206496-4
5	AS SHOWN EXCEPT EVCEPT ON TAPE	206496-2
2	AS SHOWN	206496-1

THIS DRAWING IS A CONTROLLED DOCUMENT. DWG: T. THOMPSON 06-03-94
 CHK: F. KINSEY
 AP'D: F. KINSEY
 PRODUCT SPEC

TE Connectivity
 CONTACT ASSEMBLY, SOCKET, SIZE 22D

DIMENSIONS: INCHES	TOLERANCES UNLESS OTHERWISE SPECIFIED:	0 PLC ± .005	1 PLC ± .005	2 PLC ± .005	3 PLC ± .005	4 PLC ± .005	ANGLES ± .5°
MATERIAL: SEE CALLOUT	FINISH: -	WEIGHT: 0.000000	SIZE: A1	CAGE CODE: 00779	DRAWING NO: C=206496	RESTRICTED TO: -	SCALE: 20:1

CUSTOMER DRAWING SHEET 1 OF 1 REV G

单击下面可查看定价，库存，交付和生命周期等信息

[>>TE Connectivity\(泰科\)](#)