

LOC	DIST	REVISIONS					
AR	36	P	LTR	DESCRIPTION	DATE	DWN	APVD
		A		REV PER EC 0S12-0573-04	05-05-05	JA	SF

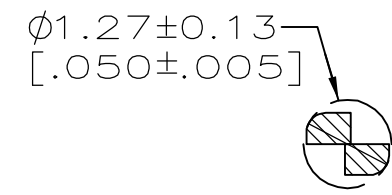

SECTION A-A
 SCALE 10:1
 6 PLACES

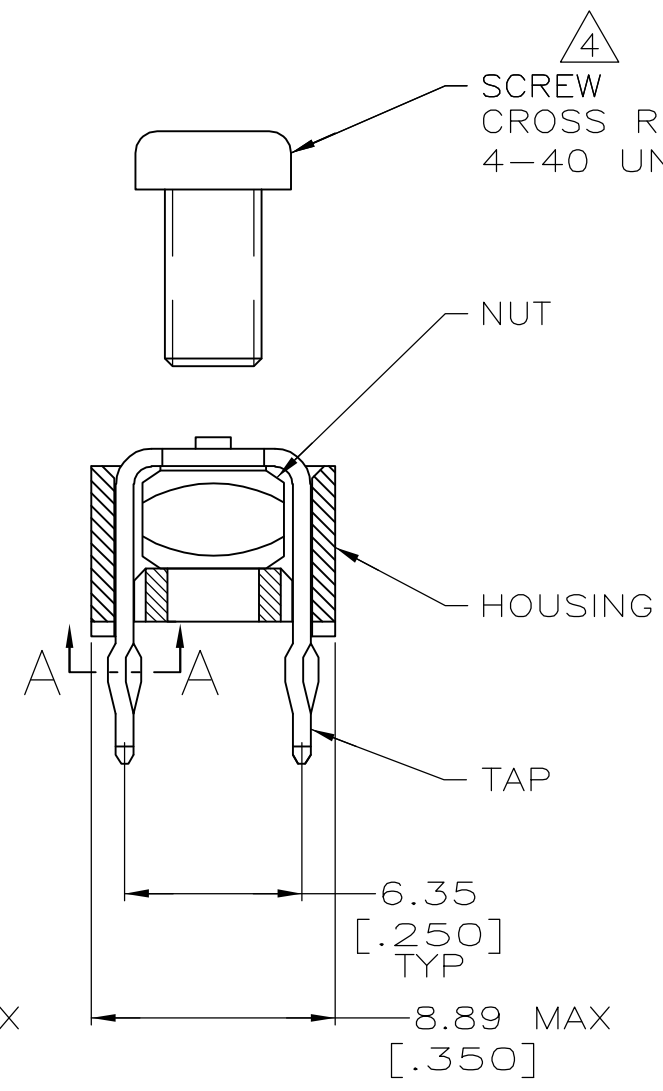
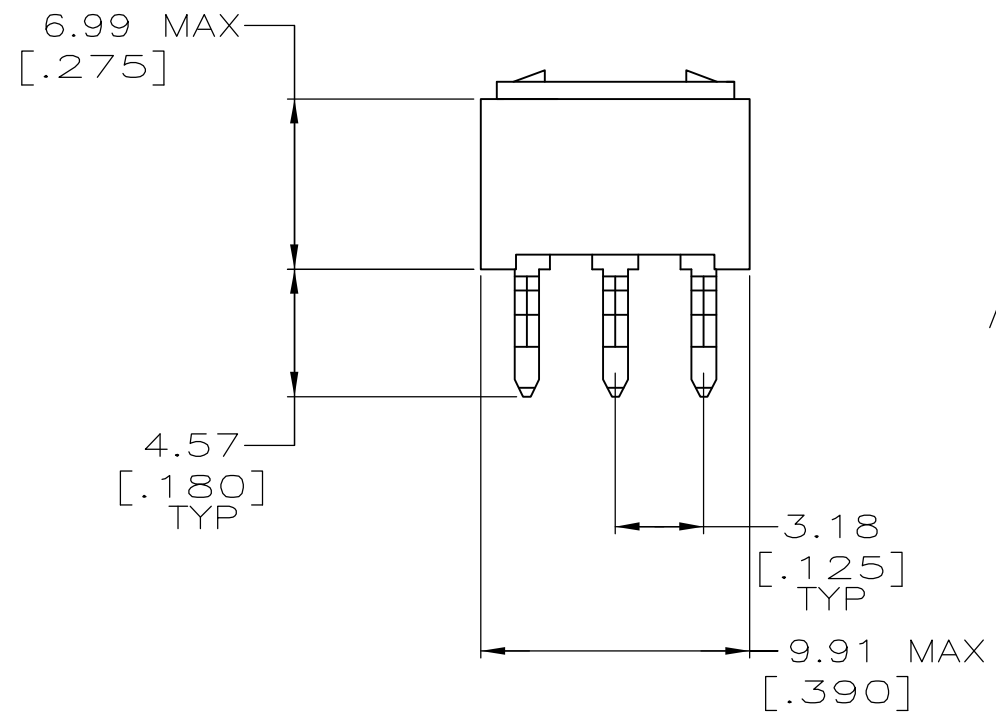

SCREW
 CROSS RECESSED PAN HEAD
 4-40 UNC2A X 6.35 [.250] LONG

- ① HOUSING: NYLON UL 94V-0, BLACK.
 NUT: CARBON STEEL.
 SCREW: STAINLESS STEEL.
 TAP: COPPER ALLOY 735.
- ② NUT: 5.08 μ m [.000200] MIN ZINC OVER
 1.27 μ m [.000050] MIN NICKEL.
 TAP: 3.81 μ m [.000150] MIN MATTE TIN OVER
 1.27 μ m [.000050] MIN NICKEL.
- 3. TO PREVENT THREAD STRIPPING, SCREW TORQUE
 SHOULD NOT EXCEED .9Nm [8.00 IN LBS].
- ④ SUPPLIED UNASSEMBLED.
- 5. BULK PACKAGED.
- ⑥ REFERENCE APPLICATION SPECIFICATION
 114-11000 FOR DRILL HOLE SIZES
 AND FINISHES.

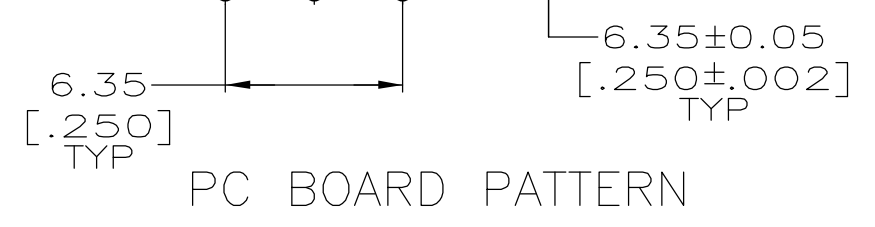
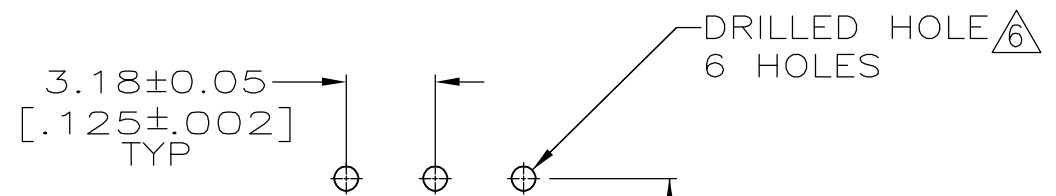

5796131-2
 PART
 NUMBER

THIS DRAWING IS A CONTROLLED DOCUMENT.		DWN	05-05-05	tyco Electronics	Tyco Electronics Corporation Harrisburg, Pa 17105-3608		
DIMENSIONS: mm [INCHES]		J. ALCORTA -	DOCK5		NAME		
TOLERANCES UNLESS OTHERWISE SPECIFIED:		CHK	05-05-05	S. FLICKINGER			
0 PLC ± -		APVD	05-05-05	PRODUCT SPEC			
1 PLC ± -				108-11030			
2 PLC ± 0.25 [.010]				APPLICATION SPEC			
3 PLC ± -				114-11000			
4 PLC ± -				SIZE	CAGE CODE	DRAWING NO	RESTRICTED TO
ANGLES ± 2°				A3	00779	5796131	-
MATERIAL	FINISH	WEIGHT		CUSTOMER DRAWING			
①	②	-		SCALE	1:1	SHEET	1 OF 1
				REV A			

单击下面可查看定价，库存，交付和生命周期等信息

[>>TE Connectivity\(泰科\)](#)