

4

3

2

1

THIS DRAWING IS UNPUBLISHED.

RELEASED FOR PUBLICATION

20

© COPYRIGHT 20 BY -

ALL RIGHTS RESERVED.

REVISIONS

P	LTR	DESCRIPTION	DATE	DWN	APVD
	B	ECR-15-013759	12OCT2015	DW	CW
	B1	ECR-16-009892	14JUL2016	RL	CW
	B2	ECR-16-018198	13JAN2017	QY	CW
	C	ECR-21-106515	09JUL2021	SQ	CW

TYPE-1:T2040104101-000 TE LOGO
 类型-1:T2040104101-000 TE LOGO

NOTES:

1. TECHNICAL CHARACTERISTICS:
 INSULATION MATERIAL: PC
 RATED VOLTAGE: 500V
 RATED CURRENT: 16A
 INSULATION RESISTANCE: $\geq 400M\Omega$
 RATED IMPULSE VOLTAGE: 6KV
 POLLUTION DEGREE: 3
 FLAMMABILITY: UL94V-0
 MATING CYCLES: 500 CYCLES
 WIRE RANGE: $0.14mm^2 \sim 4mm^2$ (AWG26-AWG12)
 CONTACT TYPE: CRIMP CONTACT

2. CONTACTS NEED TO BE ORDERED SEPARATELY.
 (ORDER No. REFER TO DRAWING:T20300X10XX000)

M4 SCREW, RECOMMENDED
 TIGHTENING TORQUE 1.2Nm
 M4螺丝, 推荐扭力矩为1.2Nm

4X M3 SCREW RECOMMENDED
 TIGHTENING TORQUE 0.5Nm
 4 X M3螺丝, 推荐扭力矩为 0.5Nm

注释:

1. 技术参数:
 绝缘材料: PC
 额定电压: 500V
 额定电流: 16A
 绝缘电阻: $\geq 400M\Omega$
 脉冲电压: 6KV
 污染等级: 3
 阻燃等级: UL94V-0
 插拔次数: 500次
 接线范围: $0.14mm^2 \sim 4mm^2$ (AWG26-AWG12)
 接线类型: 冷压接

2. 端子需要单独订购.
 (订货号参考图面: T20300X10XX000)

PANEL CUT OUT FOR INSERTS FOR
 USE WITHOUT HOODS/HOUSING
 不使用防护外壳时元件的安装开孔图

THIS DRAWING IS A CONTROLLED DOCUMENT.

DIMENSIONS:	TOLERANCES UNLESS OTHERWISE SPECIFIED:
mm	
	0 PLC \pm
	1 PLC \pm
	2 PLC \pm
	3 PLC \pm
	4 PLC \pm
	ANGLES \pm
MATERIAL	FINISH

DWN	Gino.Yao	09APR2015
CHK	Chris.Wang	09APR2015
APVD	Xiang.Xu	09APR2015
PRODUCT SPEC	108-137044	
APPLICATION SPEC	114-137044	
WEIGHT	-	
Customer Drawing		

TE Connectivity

NAME		HE-010-MC	
SIZE	CAGE CODE	DRAWING NO	RESTRICTED TO
A3	00779	©-T2040104101000	-
SCALE		SHEET	REV
1:1		1 OF 2	C

1470-19 (3/13)

Downloaded From Onevac.com

THIS DRAWING IS UNPUBLISHED.

RELEASED FOR PUBLICATION

20

© COPYRIGHT 20 BY -

ALL RIGHTS RESERVED.

REVISIONS

P	LTR	DESCRIPTION	DATE	DWN	APVD
	-	SEE SHEET 1	-	-	-

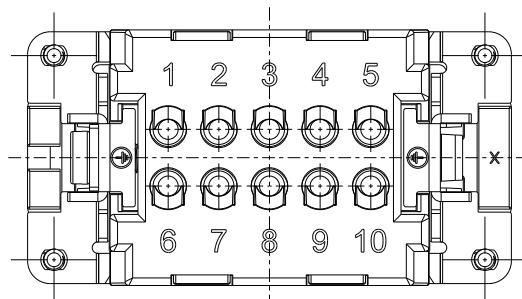

NOTES:
SEE SHEET 1
注释:
见页 1

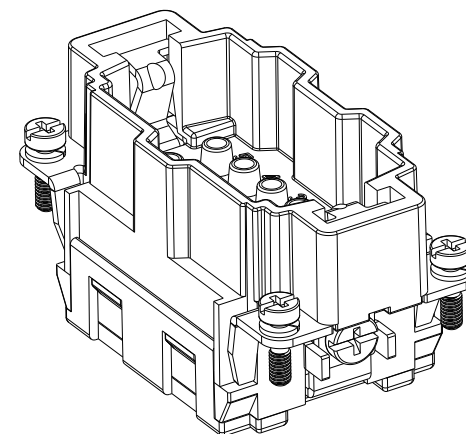
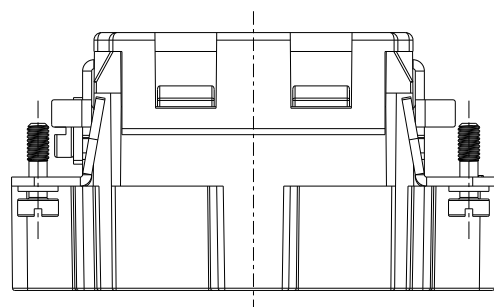
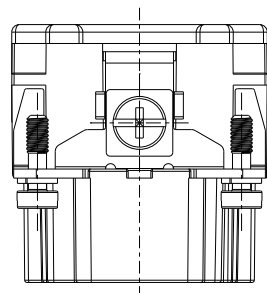

ALL DIMENSIONS ARE SAME AS TYPE 1,
EXCEPT THOSE DEFINED IN THIS TYPE.
除了在本类型中定义的尺寸外, 其它尺寸同类型 1

TYPE-2: T2040104101-001 STAINLESS STEEL SCREW, NO LOGO
类型-2: T2040104101-001 不锈钢螺丝, 无LOGO

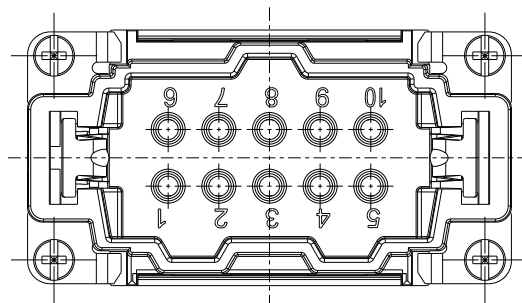

T2040104101-001	HE-010-MC	HE-010 MALE INSERT, CRIMPING, STAINLESS STEEL SCREW, NO LOGO HE-010公插, 冷压, 不锈钢螺丝, 无LOGO	TYPE-2 类型-2
T2040104101-000	HE-010-MC	HE-010 MALE INSERT, CRIMPING HE-010公插, 冷压	TYPE-1 类型-1
PART NUMBER 料号	PART DESCRIPTION 描述		TYPE 类型

THIS DRAWING IS A CONTROLLED DOCUMENT.		DWN Gino.Yao 09APR2015	 TE Connectivity NAME HE-010-MC						
DIMENSIONS: mm		CHK Chris.Wang 09APR2015			PRODUCT SPEC 108-137044				
TOLERANCES UNLESS OTHERWISE SPECIFIED:		APVD Xiang.Xu 09APR2015			APPLICATION SPEC 114-137044				
0 PLC ±- 1 PLC ±- 2 PLC ±- 3 PLC ±- 4 PLC ±- ANGLES ±- FINISH -		WEIGHT -			RESTRICTED TO -				
MATERIAL -		Customer Drawing	SIZE A3	CAGE CODE 00779	DRAWING NO T2040104101000	SCALE 1:1	SHEET 2	OF 2	REV C

单击下面可查看定价，库存，交付和生命周期等信息

[>>TE Connectivity\(泰科\)](#)