

THIS DRAWING IS UNPUBLISHED. RELEASED FOR PUBLICATION OCT. 2001.
 © COPYRIGHT 2001 By - ALL RIGHTS RESERVED.

LOC	DIST	REVISIONS			
P	LTR	DESCRIPTION	DATE	DWN	APVD
J	/				
	K3	REVISED PER ECO-11-005033	28MAR11	RK	HMR

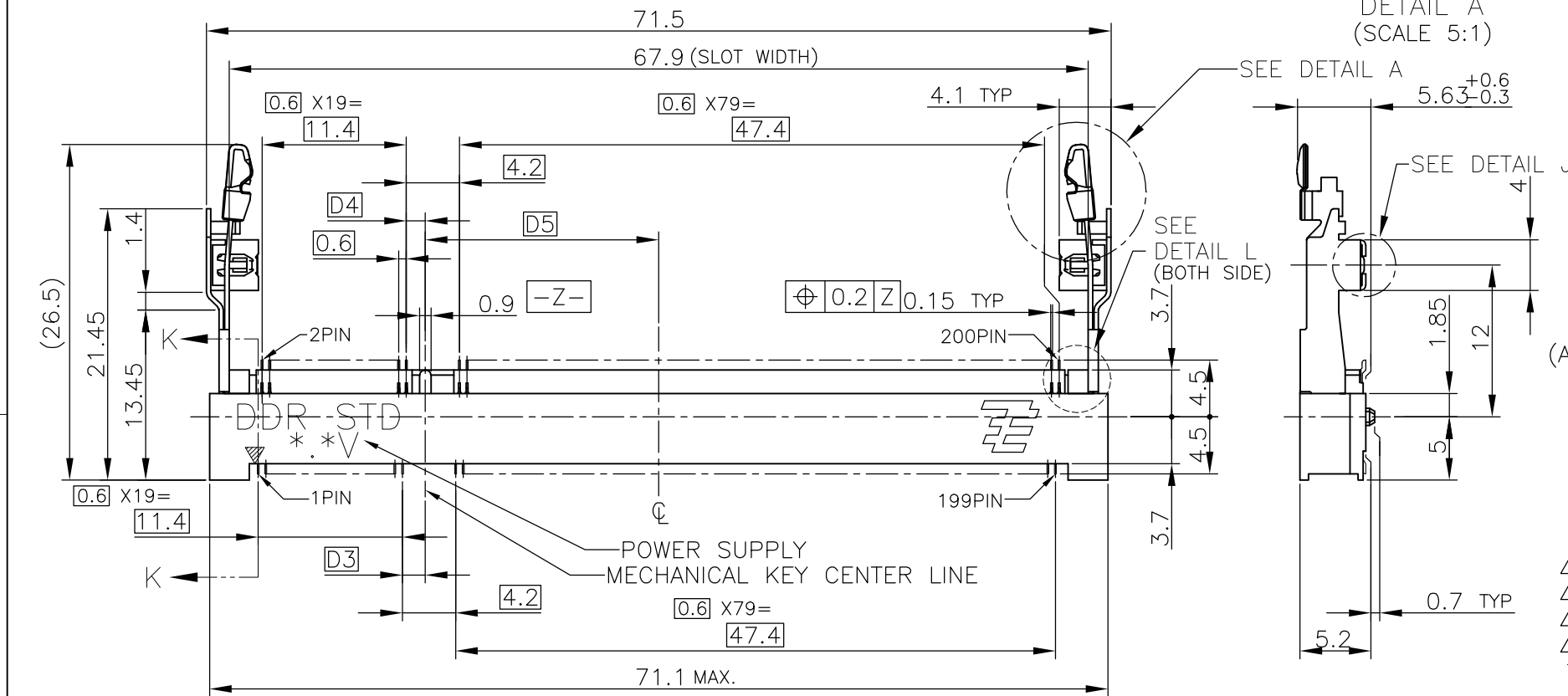

HOW TO MATE AND UNMATE
 MATE: ① → ④
 UNMATE: ⑤ → ⑦

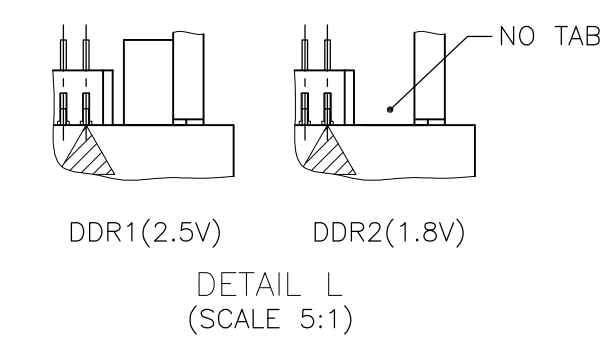
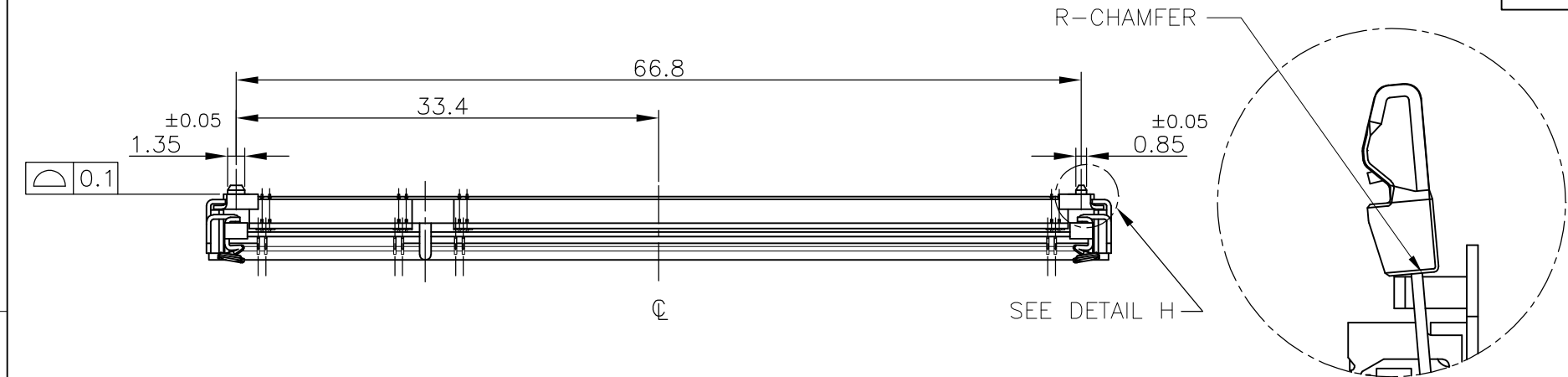
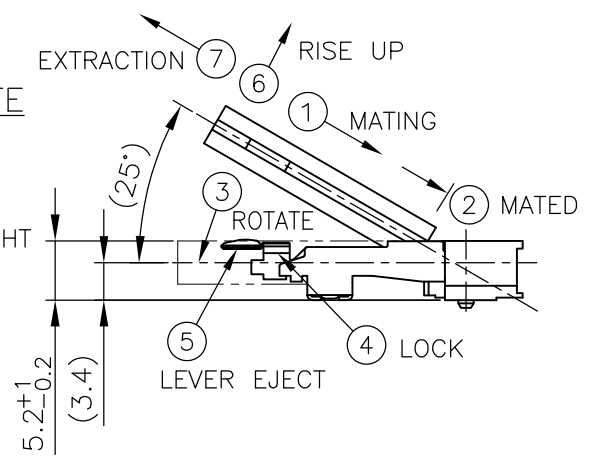

- (APPLIED TO SHEET 1-2)
- MATERIAL ; HOUSING: HIGH TEMPERATURE THERMO PLASTIC UL94V-0
 CONTACT: COPPER ARROY
 LOCK LEVER STAINLESS STEEL
 SOLDER PEG: COPPER ARROY
 - FINISH ; CONTACT AREA: GOLD FLASH ON 0.0013MIN ALL OVER NICKEL.
 SOLDERING AREA: GOLD FLASH PLT.
 SOLDER PEG: TIN PLATING.
- ⊕ MECHANICAL KEY POSITION OF CONNECTOR SEE TABLE.
 - ⊕ TOLERANCES NON-CUMULATIVE.
 - ⊕ NOT TO SCALE.
 - ⊕ [] INSIDE MUST BE RESIST COAT EXCEPT SOLDER PATTERN.
7. IF THE MODULE DOESN'T INSERT AND LOCK IN THE LATCH SMOOTHLY, OPEN WIDE BOTH LATCHES BY MANUAL. AND THE MODULE MUST BE INSERTED AND LOCKED IN THE LATCH.

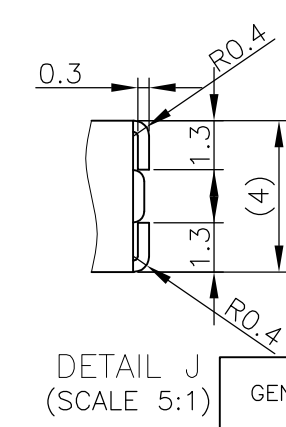
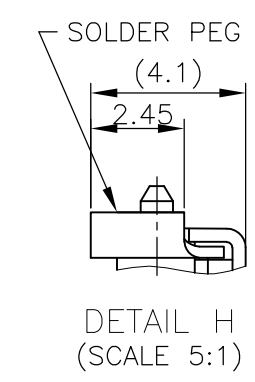
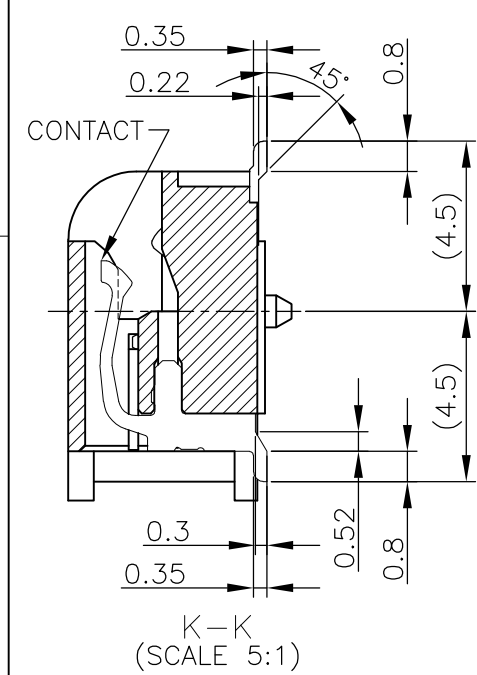

GENERAL TOLERANCE
 10 ≥ : ±0.2
 30 ≥ > 10 : ±0.25
 100 ≥ > 30 : ±0.3
 ANGLES : ±3°

TIN PLATING	AVAILABLE	1.8V (DDR2)	17.55	2.4	2.7	200	1-1473149-4
	AVAILABLE	1.8V (DDR2)	17.55	2.4	2.7	200	1473149-4
	AVAILABLE	2.5V (DDR1)	18.45	1.5	1.8	200	1473149-1
REMARK (PEG)	TOOLING STATUS	POWER SUPPLY	D5	D4	D3	POS	PART NO.
THIS DRAWING IS A CONTROLLED DOCUMENT.		DWN T.FUMIKURA	16JAN02		TE Connectivity DDR1 & DDR2 SODIMM SOCKET 0.6mm PITCH 200POS STANDARD PROFILE STANDARD TYPE (NEW LATCH TYPE)		
DIMENSIONS: MM		CHK T.KUSUHARA	17JAN02				
TOLERANCES UNLESS OTHERWISE SPECIFIED:		APVD I.ENOMOTO	17JAN02				
0 PLC ± 1 PLC ± 2 PLC ± 3 PLC ± 4 PLC ± ANGLES ± FINISH ±		NAME					
MATERIAL		PRODUCT SPEC		DRAWING NO		RESTRICTED TO	
		108-5701		CAGE CODE		A300779	
		APPLICATION SPEC		DRAWING NO		C-1473149	
		WEIGHT		SCALE		2:1	
		4.7g		SHEET		1 OF 4	
		CUSTOMER DRAWING		REV		K3	

LOC		DIST		REVISIONS			
J		P	LTR	DESCRIPTION	DATE	DWN	APVD
		-	-	SEE SHEET 1	-	-	-

REFERENCE P.C.BOARD PATTERN LAYOUT (CONNECTOR MOUNTING SIDE)

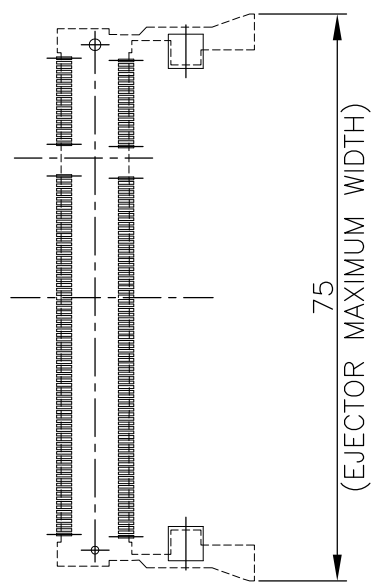

REAL SIZE (SCALE 1:1)

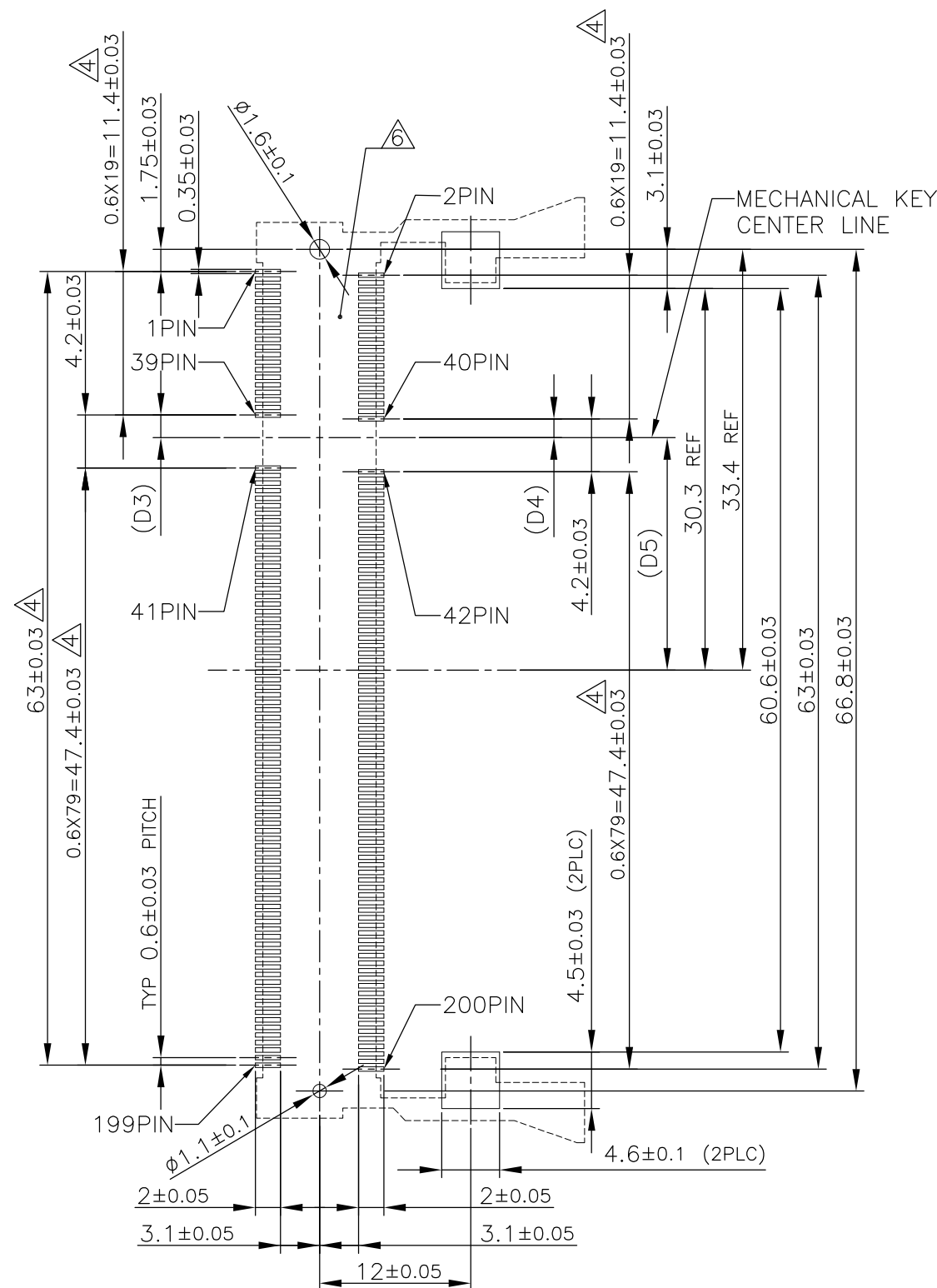

1.8V	17.55	2.4	2.7
2.5V	18.45	1.5	1.8
POWER SUPPLY	D5	D4	D3

THIS DRAWING IS A CONTROLLED DOCUMENT.		DWN		STE TE Connectivity	
DIMENSIONS: MM		CHK			
TOLERANCES UNLESS OTHERWISE SPECIFIED:		APVD		NAME	
0 PLC ±		PRODUCT SPEC		DDR1 & DDR2 SODIMM SOCKET	
1 PLC ±		APPLICATION SPEC		0.6mm PITCH 200POS	
2 PLC ±		WEIGHT		STANDARD PROFILE STANDARD TYPE (NEW LATCH TYPE)	
3 PLC ±		CUSTOMER DRAWING		SIZE	CAGE CODE
4 PLC ±		SCALE 2:1		A3	00779
ANGLES ±		SHEET 2 OF 4		DRAWING NO	C-1473149
FINISH		REV K3		RESTRICTED TO	-

THIS DRAWING IS UNPUBLISHED. RELEASED FOR PUBLICATION OCT. 2001.
 © COPYRIGHT 2001 By - ALL RIGHTS RESERVED.

LOC	DIST	REVISIONS			
P	LTR	DESCRIPTION	DATE	DWN	APVD
J	/	SEE SHEET 1	-	-	-

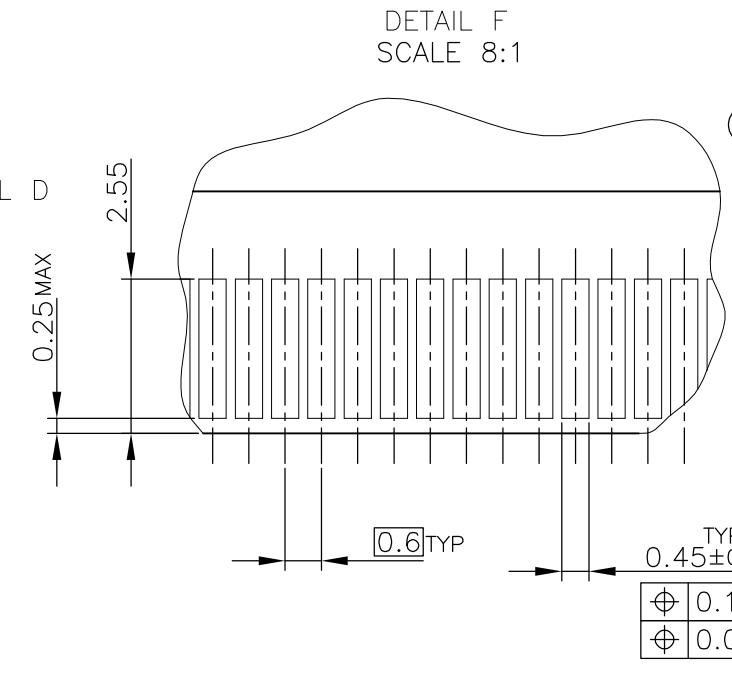
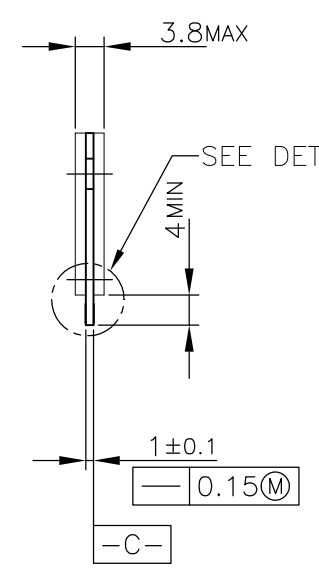
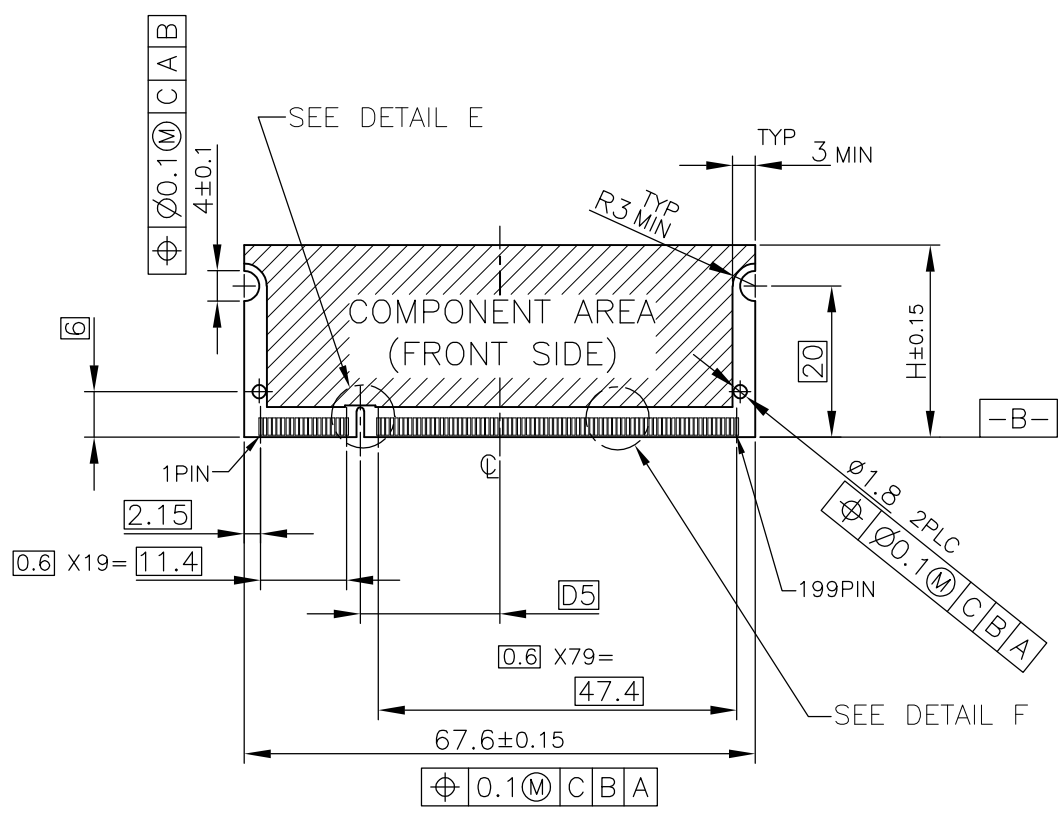

- (APPLIED TO SHEET 3)
1. TOLERANCES ON ALL DIMENSIONS ±0.15 UNLESS OTHERWISE SPECIFIED.
 2. P.C. BOARD THICKNESS APPLIES ACROSS TABS AND INCLUDES PLATING AND/OR METALIZATION.
 3. FINISH OF PAD : GOLD PLATING 0.00076 MIN. OVER Ni PLATING 0.002MIN.
- △ NO BURR
 △ CHAMFER 0.25 MAX x 45° IF EXIST.

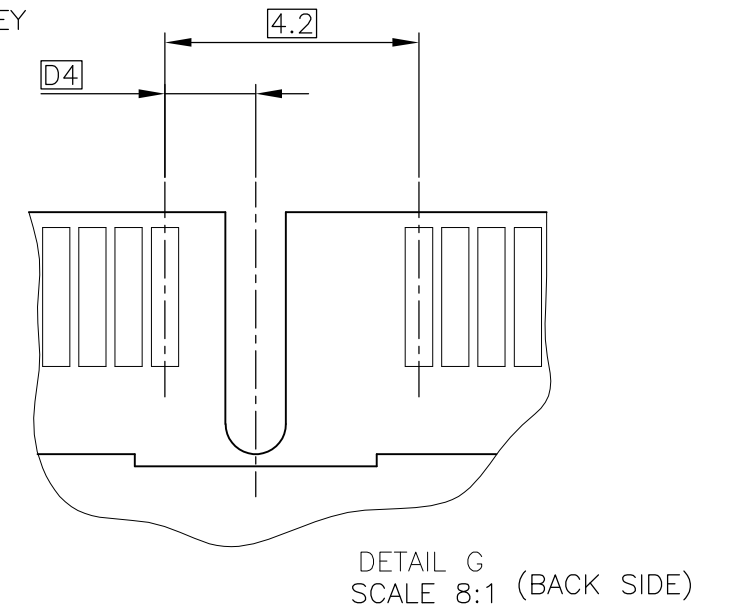
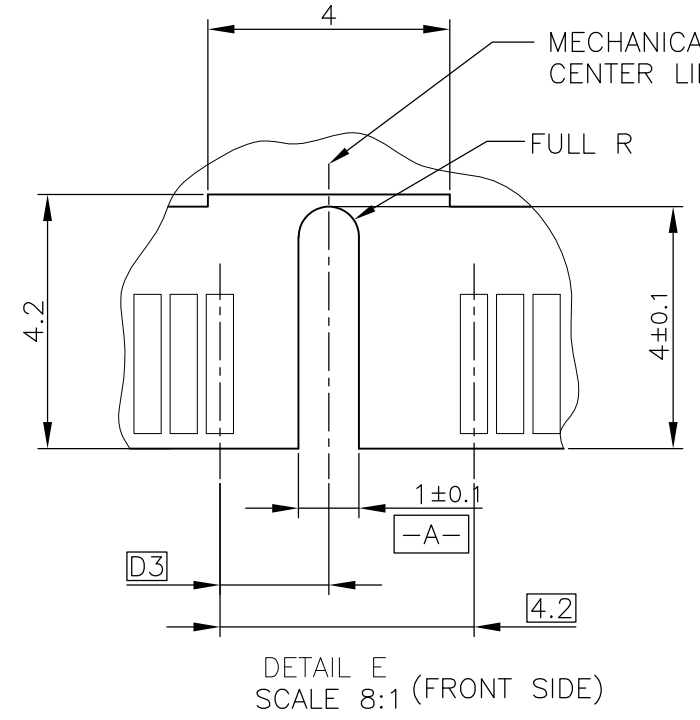
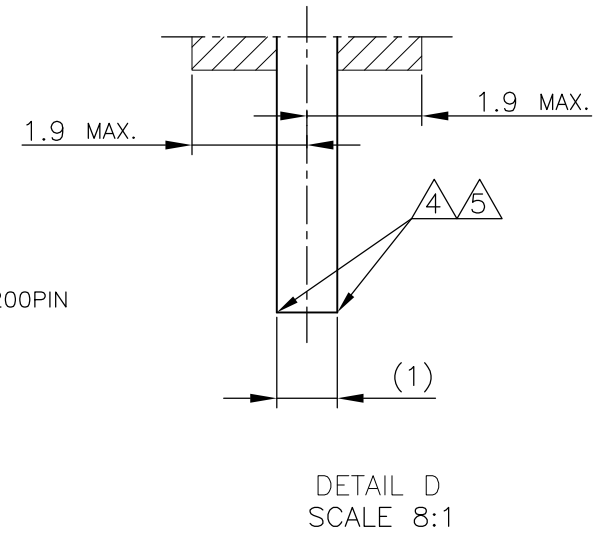
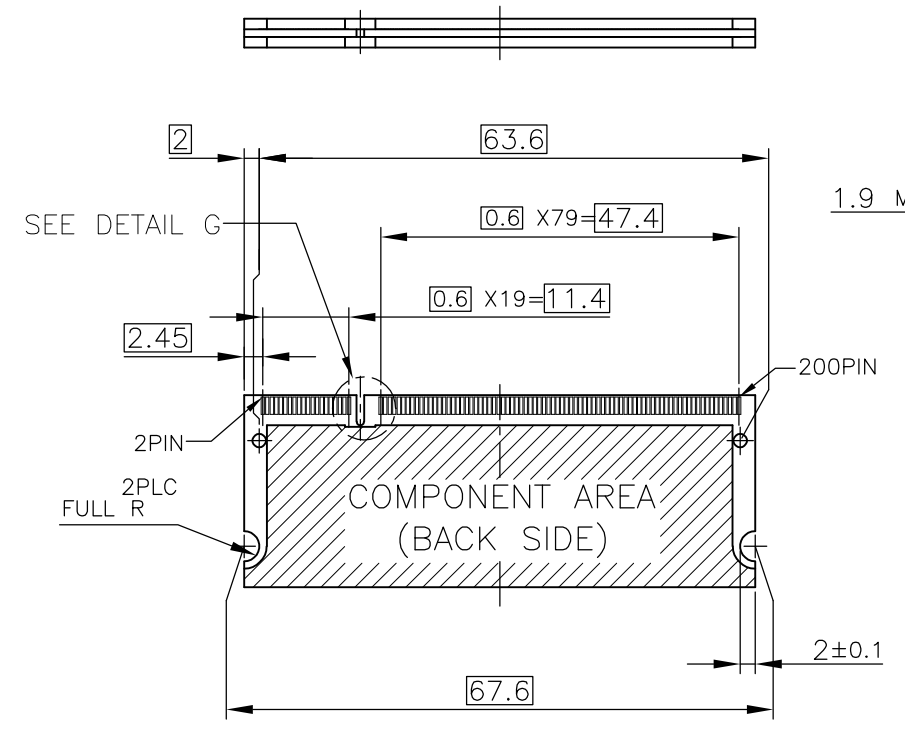

RECOMMENDED MATING P.C.B CONFIGURATION

THIS DRAWING IS A CONTROLLED DOCUMENT.		DWN		TE Connectivity NAME DDR1 & DDR2 SODIMM SOCKET 0.6mm PITCH 200POS STANDARD PROFILE STANDARD TYPE (NEW LATCH TYPE)	
DIMENSIONS: MM		CHK			
TOLERANCES UNLESS OTHERWISE SPECIFIED:		APVD			
0 PLC ± 1 PLC ± 2 PLC ± 3 PLC ± 4 PLC ± ANGLES ± FINISH ±		PRODUCT SPEC			
MATERIAL		APVD		APPLICATION SPEC	
		WEIGHT		SIZE	
		CUSTOMER DRAWING		CAGE CODE	
		SCALE 2:1		DRAWING NO	
		SHEET 3 OF 4		RESTRICTED TO	
		REV K3			

A300779 C-1473149

THIS DRAWING IS UNPUBLISHED. RELEASED FOR PUBLICATION OCT , 2001.
 © COPYRIGHT 2001 By - ALL RIGHTS RESERVED.

LOC	DIST	REVISIONS			
P	LTR	DESCRIPTION	DATE	DWN	APVD
J	/	SEE SHEET 1	-	-	-

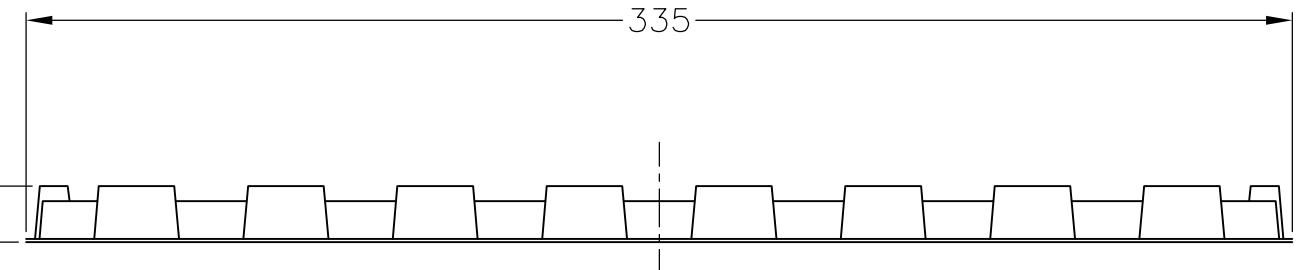
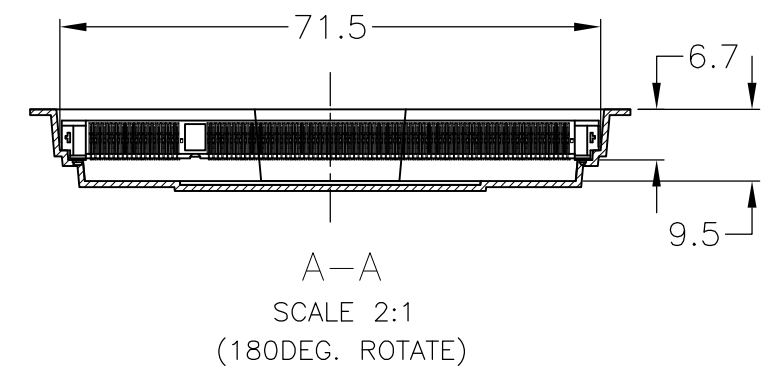
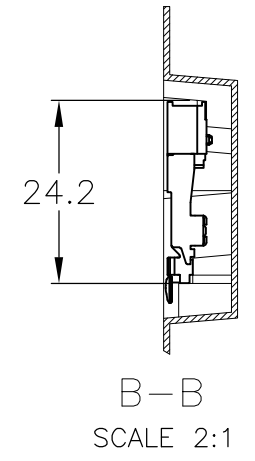
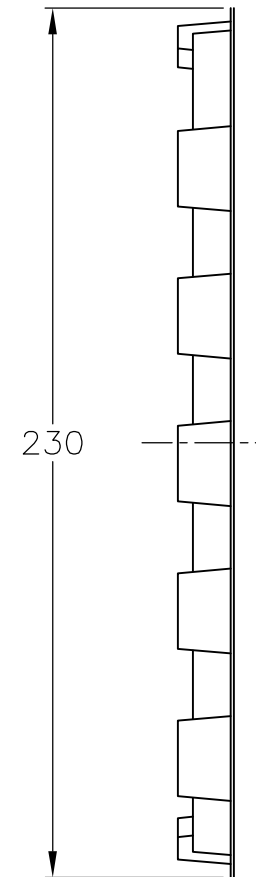
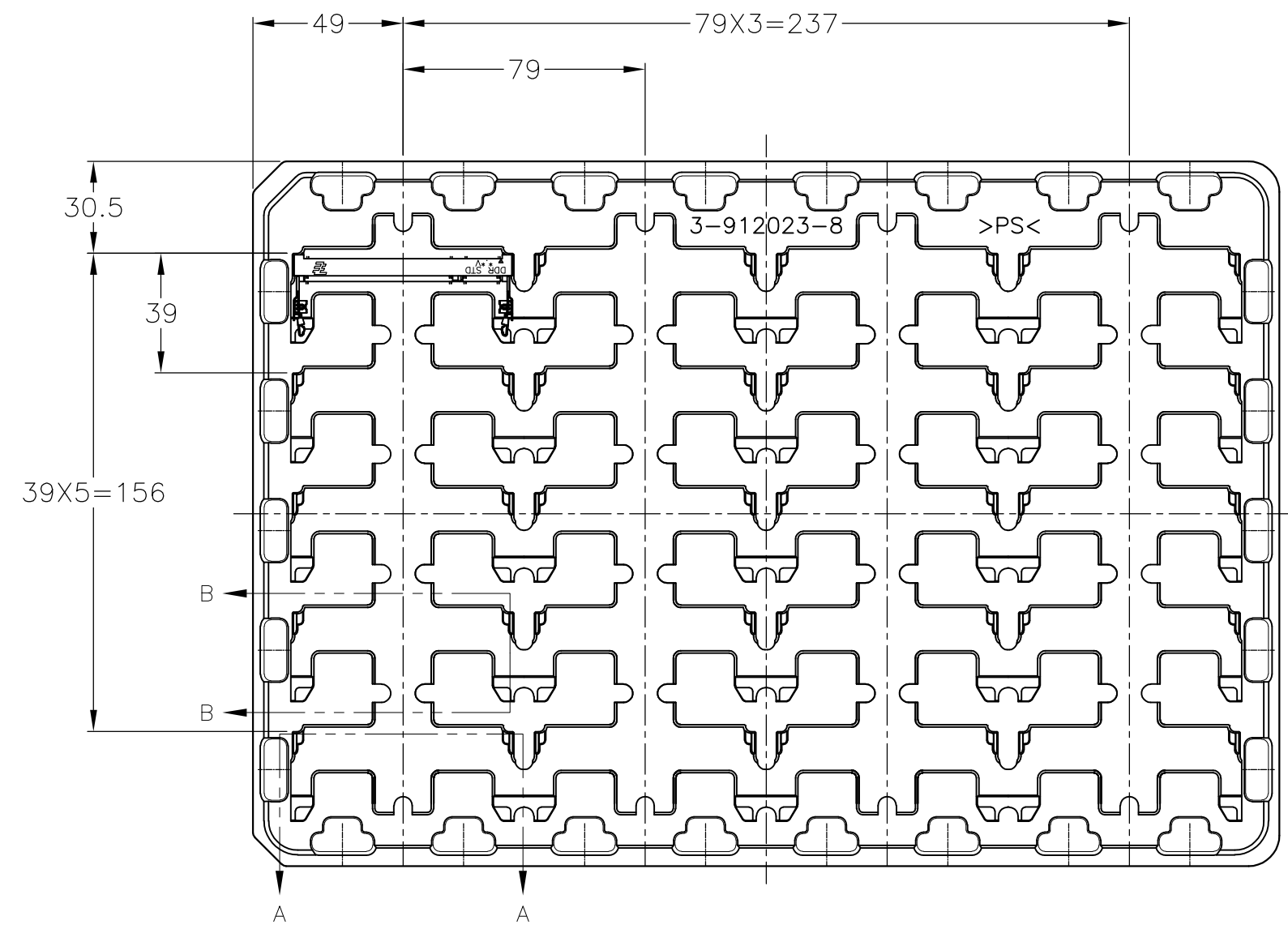

REMARK	QTY	P/N
DDR2	20EA/TRAY	1-1473149-4
DDR2	20EA/TRAY	1473149-4
DDR1	20EA/TRAY	1473149-1

- (APPLIED TO SHEET 4)
- 1 THE DIRECTION OF EACH CONNECTOR ON A TRAY IS REFERRED TO THIS DRAWING.
 - 2 GENERAL TOLERANCE: ±0.5

THIS DRAWING IS A CONTROLLED DOCUMENT.		DWN	TE Connectivity NAME: DDR1 & DDR2 SODIMM SOCKET 0.6mm PITCH 200POS STANDARD PROFILE STANDARD TYPE (NEW LATCH TYPE)		
DIMENSIONS: MM		CHK			
TOLERANCES UNLESS OTHERWISE SPECIFIED:		APVD			
0 PLC ± 1 PLC ± 2 PLC ± 3 PLC ± 4 PLC ± ANGLES ± FINISH ±		PRODUCT SPEC			
MATERIAL		APPL. SPEC	SIZE	CAGE CODE	DRAWING NO
		WEIGHT	A3	00779	C-1473149
		CUSTOMER DRAWING	SCALE	SHEET	REV
			1:2	4 OF 4	K3

单击下面可查看定价，库存，交付和生命周期等信息

[>>TE Connectivity\(泰科\)](#)