

THIS DRAWING IS UNPUBLISHED. RELEASED FOR PUBLICATION 20
 © COPYRIGHT 20 BY TYCO ELECTRONICS CORPORATION. ALL RIGHTS RESERVED.

LOC		DIST		REVISIONS			
P	LTR	DESCRIPTION	DATE	DWN	APVD		
CC	00	A	RELEASED	25NOV08	KT	PR	
		B	REV PER ECO-09-006618	24MAR2009	CR	PR	

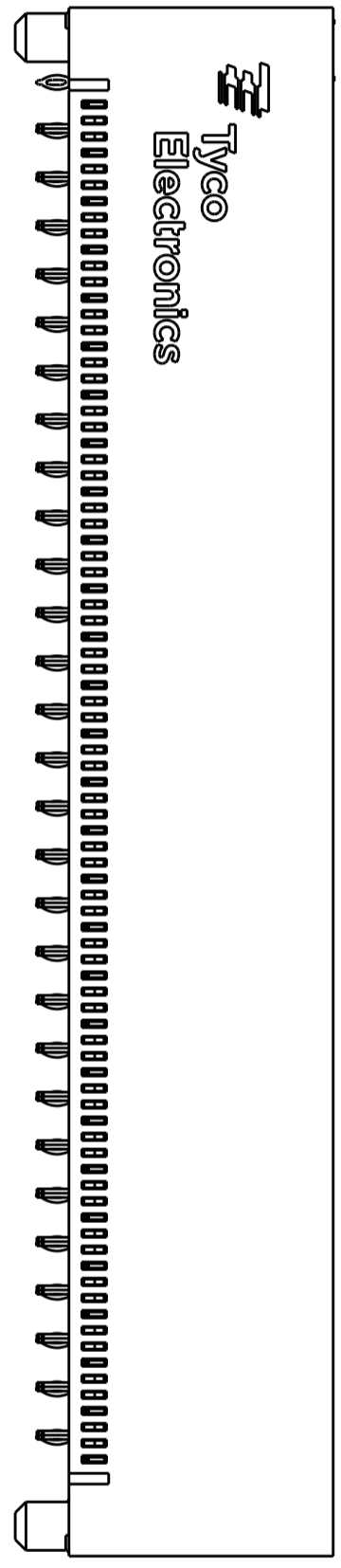

DIFFERENTIAL PAIR CONFIGURATION

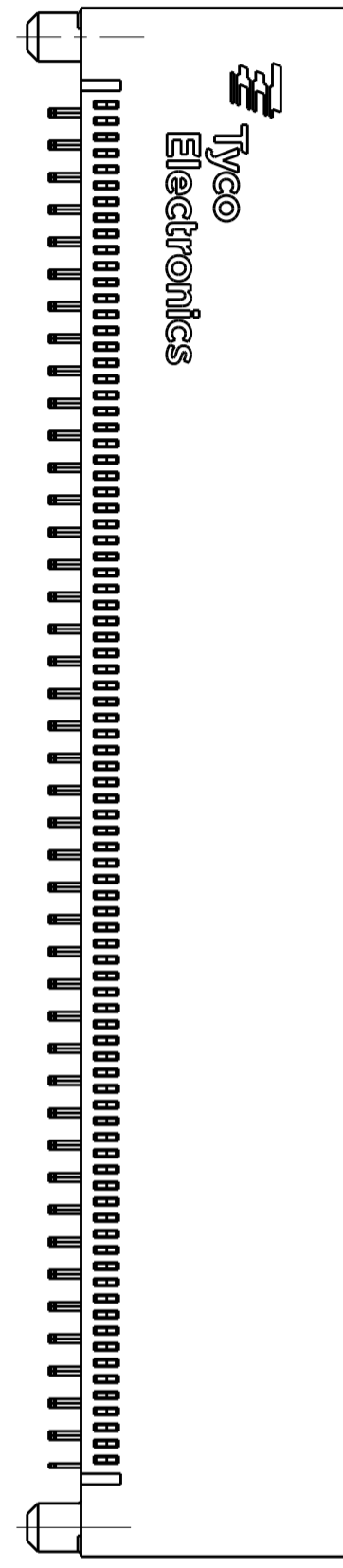

INDIVIDUAL SIGNAL CONFIGURATION

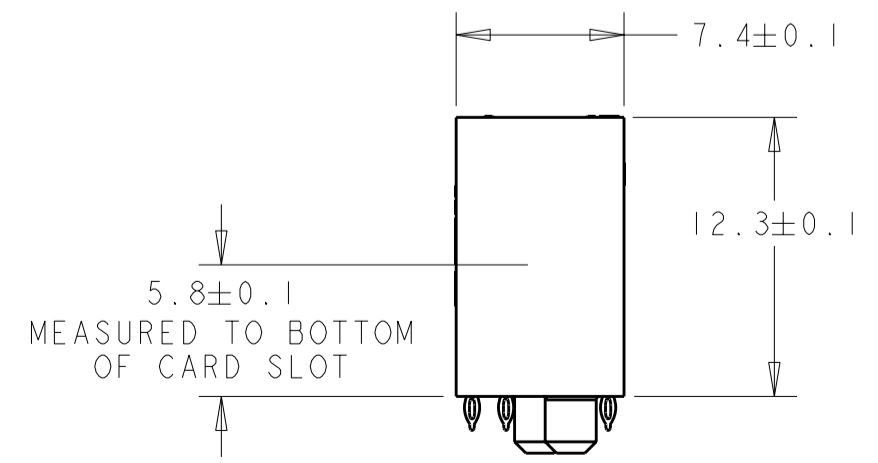
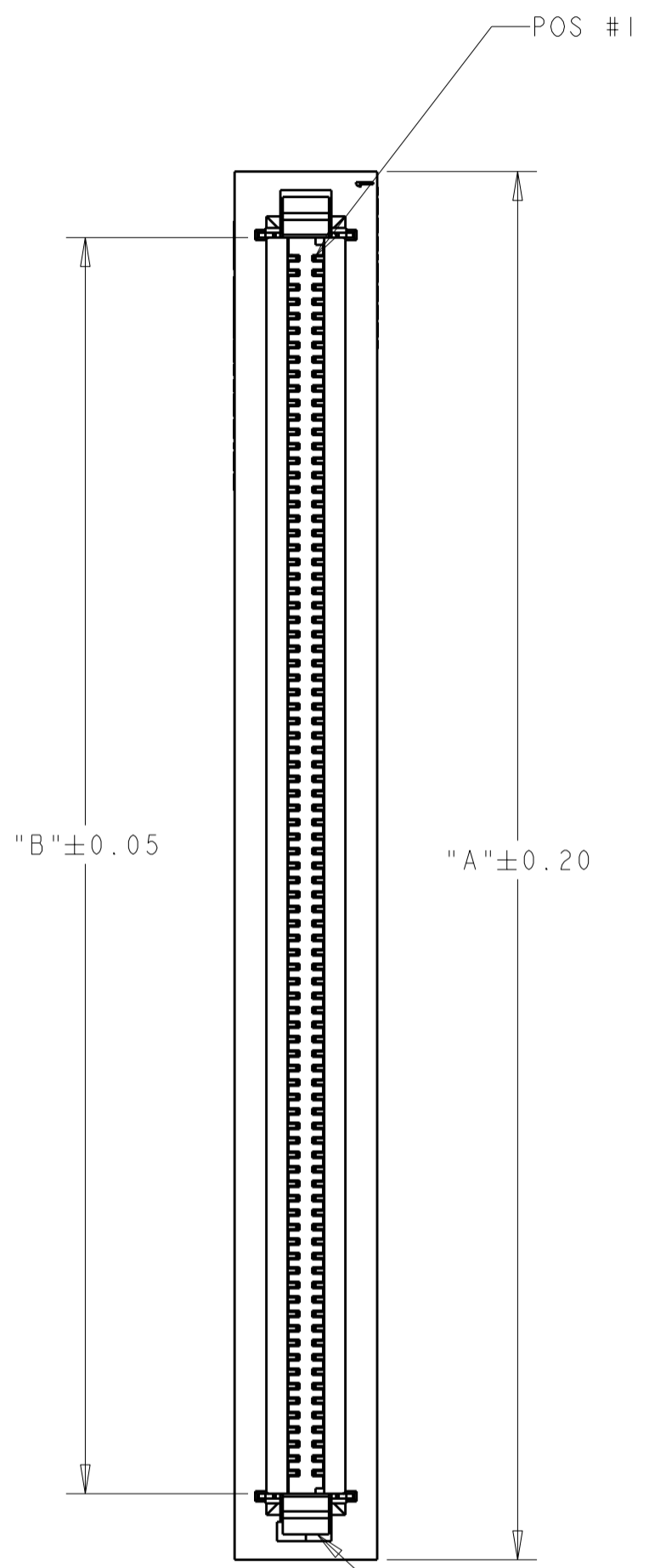

- 1 PCB HOLE DIMENSIONS:
 DRILLED HOLE = 0.64±0.02 mm
 FINISHED HOLE = 0.55 mm REF
 Cu THICKNESS = 25-50 um WITH EITHER
 PLATING THICKNESS:
 HASL Sn Pb = 4-10 um OR
 IMMERSION Sn = MIN 0.5 um OR
 OSP = 0.2-0.5 um OR
 IMMERSION Au/Ni = 0.5-1.2 um Au OVER 3.0-7.0 um Ni OR
 IMMERSION Ag = 0.1 um MIN
- 2 MATERIAL:
 HOUSING- LCP, 94V-0 RATED, COLOR- BLACK
 CONTACTS- COPPER ALLOY
 WEAR PLATE- STAINLESS STEEL
- 3 FINISH- MATING AREA- 0.76 um MIN GOLD OR
 0.64 um MIN PALLADIUM-NICKEL OVER 1.27um MIN NICKEL
 COMPLIANT PIN AREA- 0.5 um MATTE TIN OVER 1.27 um NICKEL.
- 4 CONNECTOR MARKED WITH PART NUMBER AND DATE CODE.
- 5 DATUMS AND BASIC DIMENSIONS ESTABLISHED BY CUSTOMER.
- 6 CONTACT AREA LUBRICATED WITH BELLCORE APPROVED LUBRICANT. TECHNICAL REFERENCE GR-1217-CORE ISSUE 1, NOVEMBER 1995.
- 7 REFER TO TYCO ELECTRONICS APPLICATION SPECIFICATION 114-13180 FOR SPECIFIC APPLICATION RELATED INFORMATION.
- 8 FINISH- MATING AREA- 0.76 um MIN GOLD OR
 0.64 um MIN PALLADIUM-NICKEL OVER 1.27um MIN NICKEL
 COMPLIANT PIN AREA- 0.5 um BRIGHT TIN-LEAD OVER 1.27 um NICKEL.
- 9 WEAR PLATE EXTENDS FROM TOP OF CONNECTOR TO BOTTOM OF SLOT AND IS USED TO ELIMINATE WEAR OF THE HOUSING CAUSED BY THE EDGE OF THE PCB CARD.
- 10 THESE 2 END HOLES ARE NOT REQUIRED ON 80 AND 140 POSITION PCB'S.

THIS DRAWING IS A CONTROLLED DOCUMENT FOR TYCO ELECTRONICS CORPORATION IT IS SUBJECT TO CHANGE AND THE CONTROLLING ENGINEERING ORGANIZATION SHOULD BE CONTACTED FOR THE LATEST REVISION.		DWN D. SZCZESNY	11JAN08	Tyco Electronics Harrisburg, PA 17105-3608	
DIMENSIONS: mm		CHK -	APVD -	NAME CARD EDGE CONNECTOR, VERTICAL 0.75 CENTERLINE	
TOLERANCES UNLESS OTHERWISE SPECIFIED: 0 PLC ±0.1 1 PLC ±0.5 2 PLC ±0.13 3 PLC ±0.013 4 PLC ±0.0001 ANGLES ± FINISH		PRODUCT SPEC 108-2254	APPLICATION SPEC 114-13180	SIZE A2	CAGE CODE 00779
MATERIAL -		WEIGHT -	DRAWING NO 1934768	RESTRICTED TO -	SCALE 1:1
CUSTOMER DRAWING			SHEET 1	OF 4	REV B

THIS DRAWING IS UNPUBLISHED. RELEASED FOR PUBLICATION 20
 © COPYRIGHT 20 BY TYCO ELECTRONICS CORPORATION. ALL RIGHTS RESERVED.

LOC	DIST	REVISIONS					
CC	00	P	LTR	DESCRIPTION	DATE	DWN	APVD
		-		SEE SHEET 1			

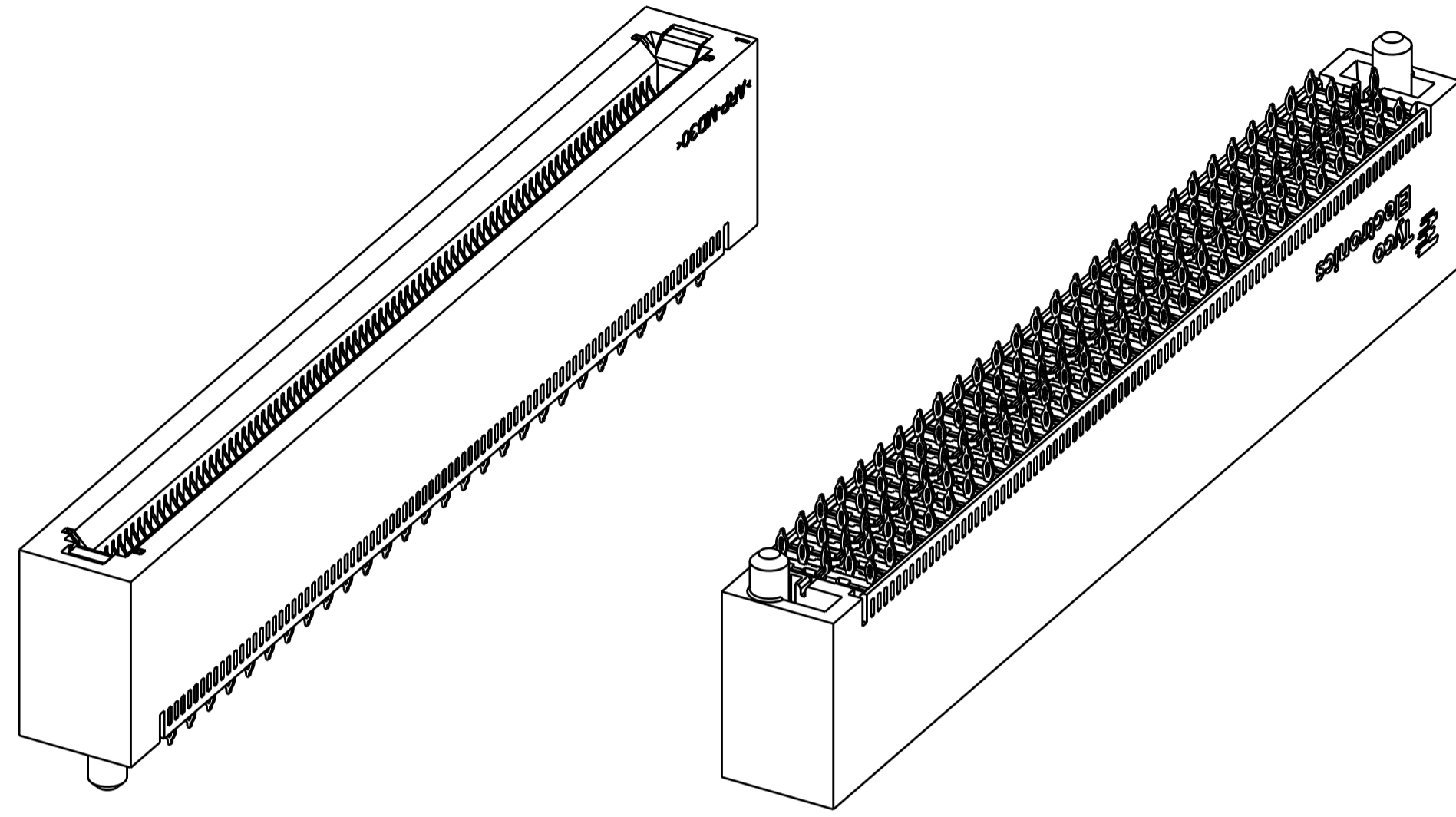

PART NUMBERS
 2-1934768-1 THRU 3-1934768-6
 DIFFERENTIAL PAIR CONFIGURATION

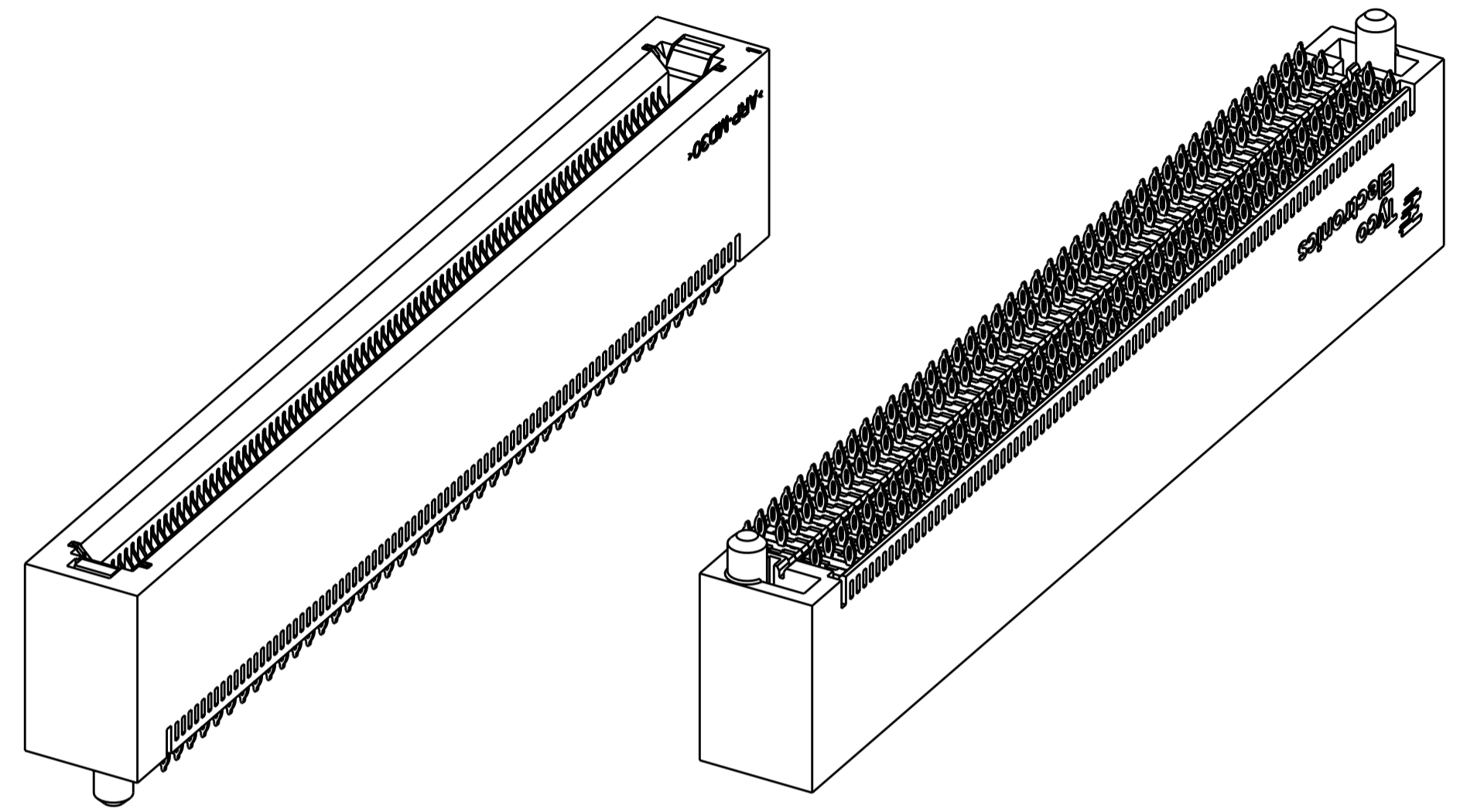

PART NUMBERS
 1-1934768-1 THRU 1-1934768-6
 INDIVIDUAL SIGNAL CONFIGURATION

65.15	72.00	56	-	8	170	3-1934768-6
53.90	60.75	46	-	8	140	3-1934768-5
42.65	48.50	36	-	8	110	3-1934768-4
31.40	38.25	26	-	8	80	3-1934768-3
20.15	27.00	16	-	8	50	3-1934768-2
47.15	54.00	40	-	8	122	3-1934768-1
65.15	72.00	56	-	3	170	2-1934768-6
53.90	60.75	46	-	3	140	2-1934768-5
42.65	49.50	36	-	3	110	2-1934768-4
31.40	38.25	26	-	3	80	2-1934768-3
20.15	27.00	16	-	3	50	2-1934768-2
47.15	54.00	40	-	3	122	2-1934768-1
65.15	72.00	-	170	8	170	1-1934768-6
53.90	60.75	-	140	8	140	1-1934768-5
42.65	49.50	-	110	8	110	1-1934768-4
31.40	38.25	-	80	8	80	1-1934768-3
20.15	27.00	-	50	8	50	1-1934768-2
47.15	54.00	-	122	8	122	1-1934768-1
65.15	72.00	-	170	3	170	1934768-6
53.90	60.75	-	140	3	140	1934768-5
42.65	49.50	-	110	3	110	1934768-4
31.40	38.25	-	80	3	80	1934768-3
20.15	27.00	-	50	3	50	1934768-2
47.15	54.00	-	122	3	122	1934768-1
"B"	"A"	DIFFERENTIAL PAIR	SIGNALS	PLATING	POSITIONS	PART NUMBER

CUSTOM LOAD PATTERNS
 ARE AVAILABLE. CONTACT
 TYCO ELECTRONICS SALES.

THIS DRAWING IS A CONTROLLED DOCUMENT FOR TYCO ELECTRONICS CORPORATION. IT IS SUBJECT TO CHANGE AND THE CONTROLLING ENGINEERING ORGANIZATION SHOULD BE CONTACTED FOR THE LATEST REVISION.		DWN D. SZCZESNY	11 JAN 08	Tyco Electronics Harrisburg, PA 17105-3608	
DIMENSIONS: mm		CHK -	APVD -	NAME CARD EDGE CONNECTOR, VERTICAL 0.75 CENTERLINE	
TOLERANCES UNLESS OTHERWISE SPECIFIED: 0 PLC ±0.1 1 PLC ±0.5 2 PLC ±0.13 3 PLC ±0.013 4 PLC ±0.0001 ANGLES ±		PRODUCT SPEC 108-2254		APPLICATION SPEC 114-13180	
MATERIAL -		WEIGHT -		SIZE A200779	CAGE CODE C-1934768
FINISH -		CUSTOMER DRAWING		SCALE 1:1	SHEET 2 OF 4 REV B

THIS DRAWING IS UNPUBLISHED. RELEASED FOR PUBLICATION 20
 © COPYRIGHT 20 BY TYCO ELECTRONICS CORPORATION. ALL RIGHTS RESERVED.

REVISIONS					
P	LTR	DESCRIPTION	DATE	DWN	APVD
-	-	SEE SHEET 1	-	-	-

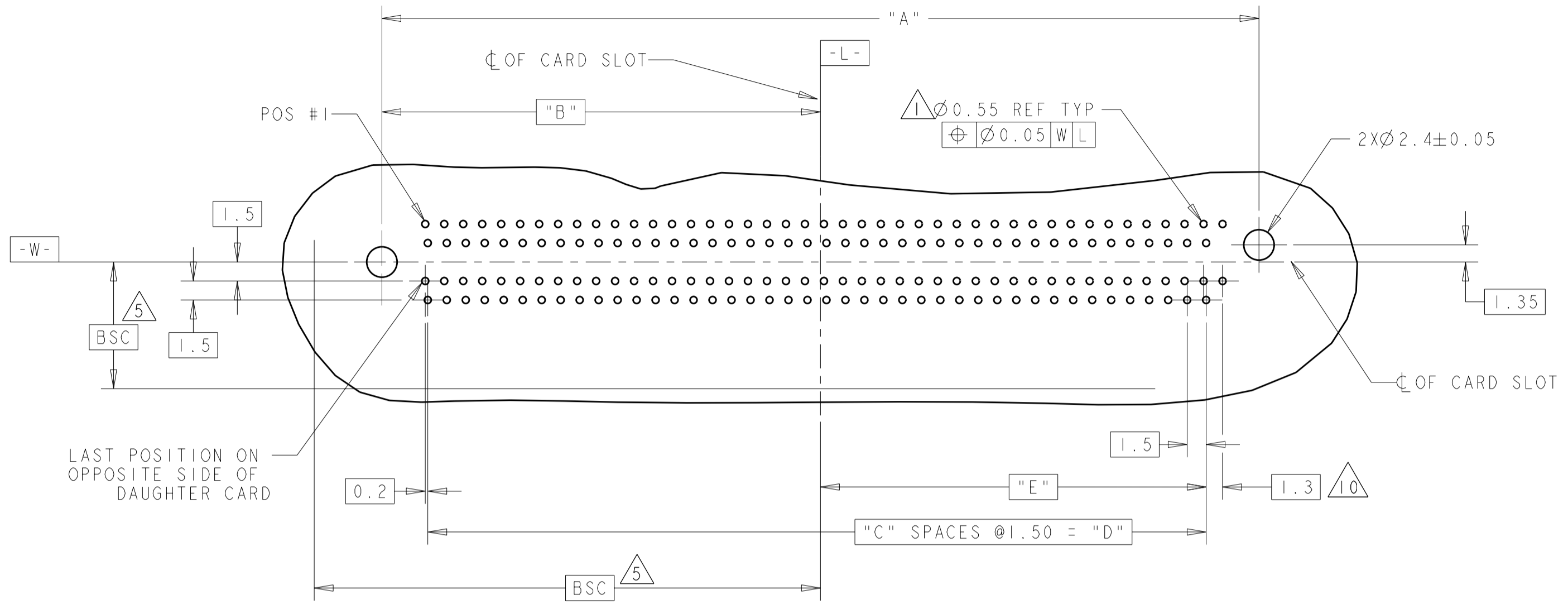

RECOMMENDED PCB LAYOUT
 INDIVIDUAL SIGNAL CONFIGURATION

DIMENSIONS FOR INDIVIDUAL SIGNAL PCB LAYOUT

"E"	"D"	"C"	"B"	"A"	CONNECTOR SIZE
30.48	61.50	41	34.65	69.30	170
25.61	51.00	34	29.03	58.05	140
21.48	43.50	29	25.65	51.30	122
19.23	39.00	26	23.40	46.80	110
14.36	28.50	19	17.78	35.55	80
7.98	16.50	12	12.15	24.30	50

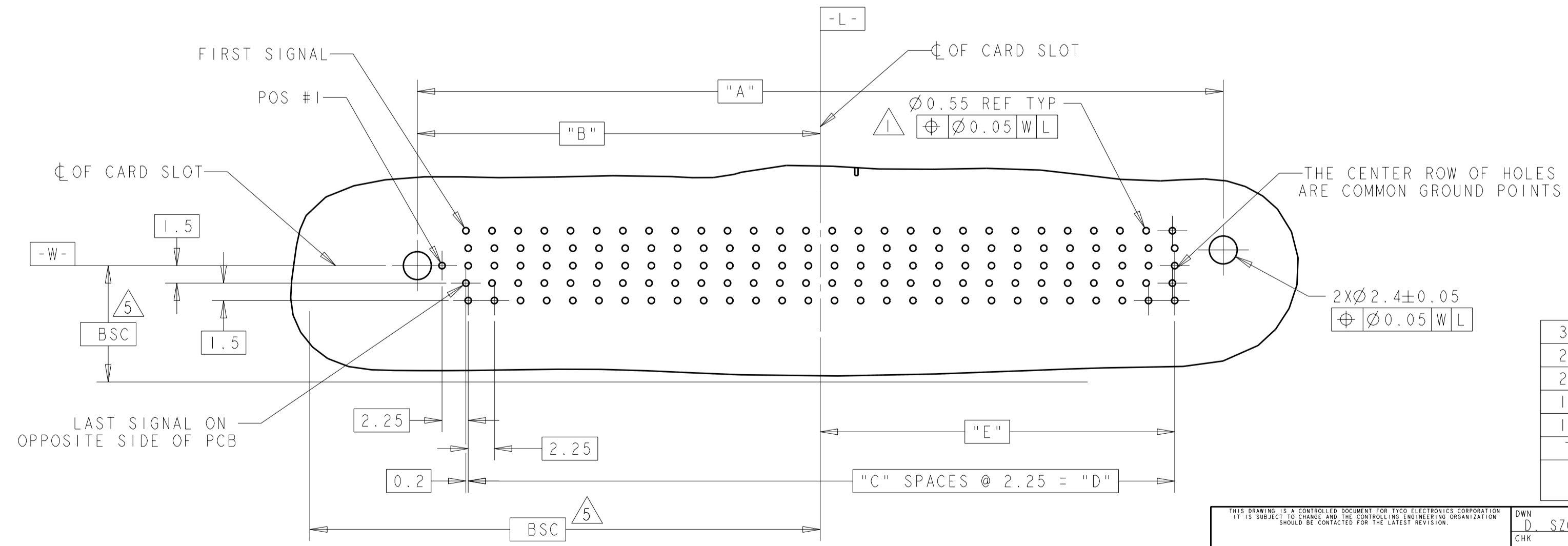

RECOMMENDED PCB LAYOUT
 DIFFERENTIAL PAIR CONFIGURATION

DIMENSIONS FOR DIFFERENTIAL PAIR PCB LAYOUT

"E"	"D"	"C"	"B"	"A"	CONNECTOR SIZE
30.48	60.75	27	34.65	69.30	170
24.86	49.50	22	29.03	58.05	140
21.48	42.75	19	25.65	51.30	122
19.23	38.25	17	23.40	46.80	110
13.61	27.00	12	17.78	35.55	80
7.98	15.75	7	12.15	24.30	50

THIS DRAWING IS A CONTROLLED DOCUMENT FOR TYCO ELECTRONICS CORPORATION. IT IS SUBJECT TO CHANGE AND THE CONTROLLING ENGINEERING ORGANIZATION SHOULD BE CONTACTED FOR THE LATEST REVISION.

DWN: D. SZCZESNY 11 JAN 08
 CHK: -
 APVD: -

PRODUCT SPEC: 108-2254
 APPLICATION SPEC: 114-13180
 WEIGHT: -

MATERIAL: -
 FINISH: -

SCALE: 1:1
 SHEET: 3 OF 4
 REV: B

NAME: CARD EDGE CONNECTOR, VERTICAL 0.75 CENTERLINE
 SIZE: A2
 CAGE CODE: 00779
 DRAWING NO: 1934768
 RESTRICTED TO: -

CUSTOMER DRAWING

THIS DRAWING IS UNPUBLISHED. RELEASED FOR PUBLICATION 20
 © COPYRIGHT 20 BY TYCO ELECTRONICS CORPORATION. ALL RIGHTS RESERVED.

LOC	DIST	REVISIONS			
P	LTR	DESCRIPTION	DATE	DWN	APVD
CC	00	SEE SHEET 1			

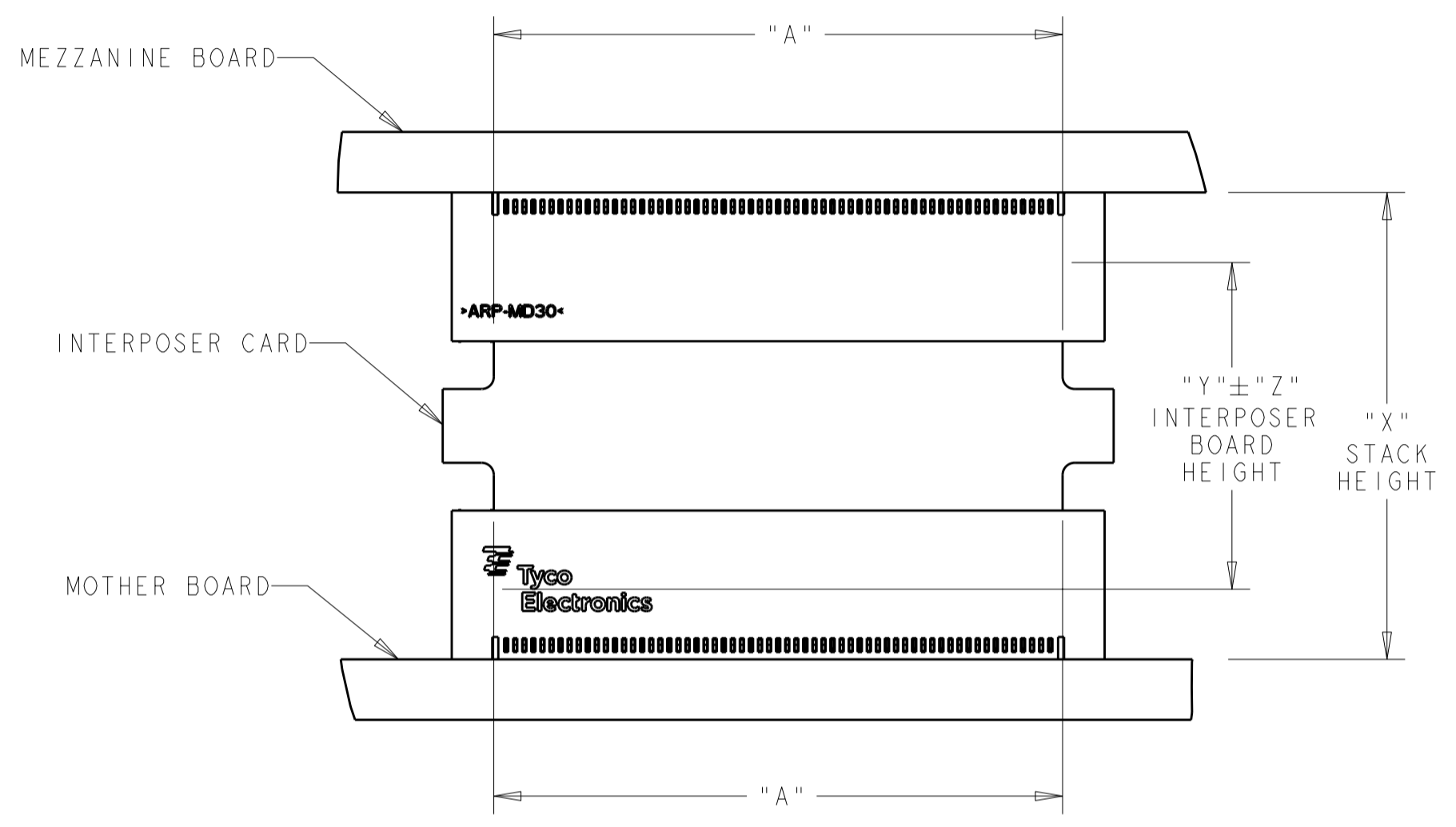
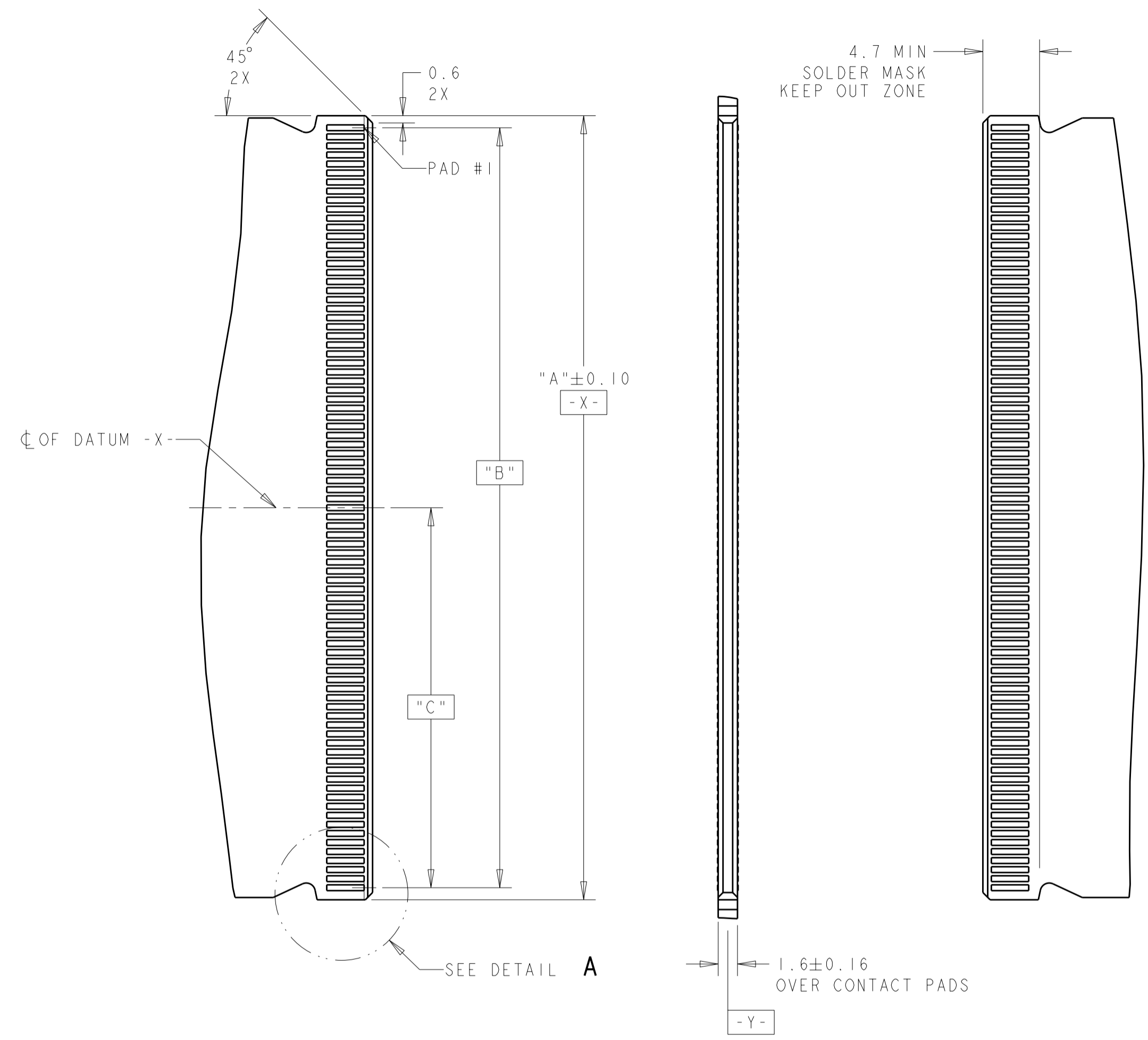

MEZZANINE APPLICATION
 FOR USE IN PARALLEL STACKING APPLICATIONS

STACK HEIGHT = INTERPOSER BOARD HEIGHT
 PLUS 11.60 ± 0.20 mm PLUS
 TOLERANCE OF INTERPOSER BOARD

$X = Y \pm Z + 11.60 \pm 0.2 \text{ mm}$

RECOMMENDED MATING
 PCB LAYOUT

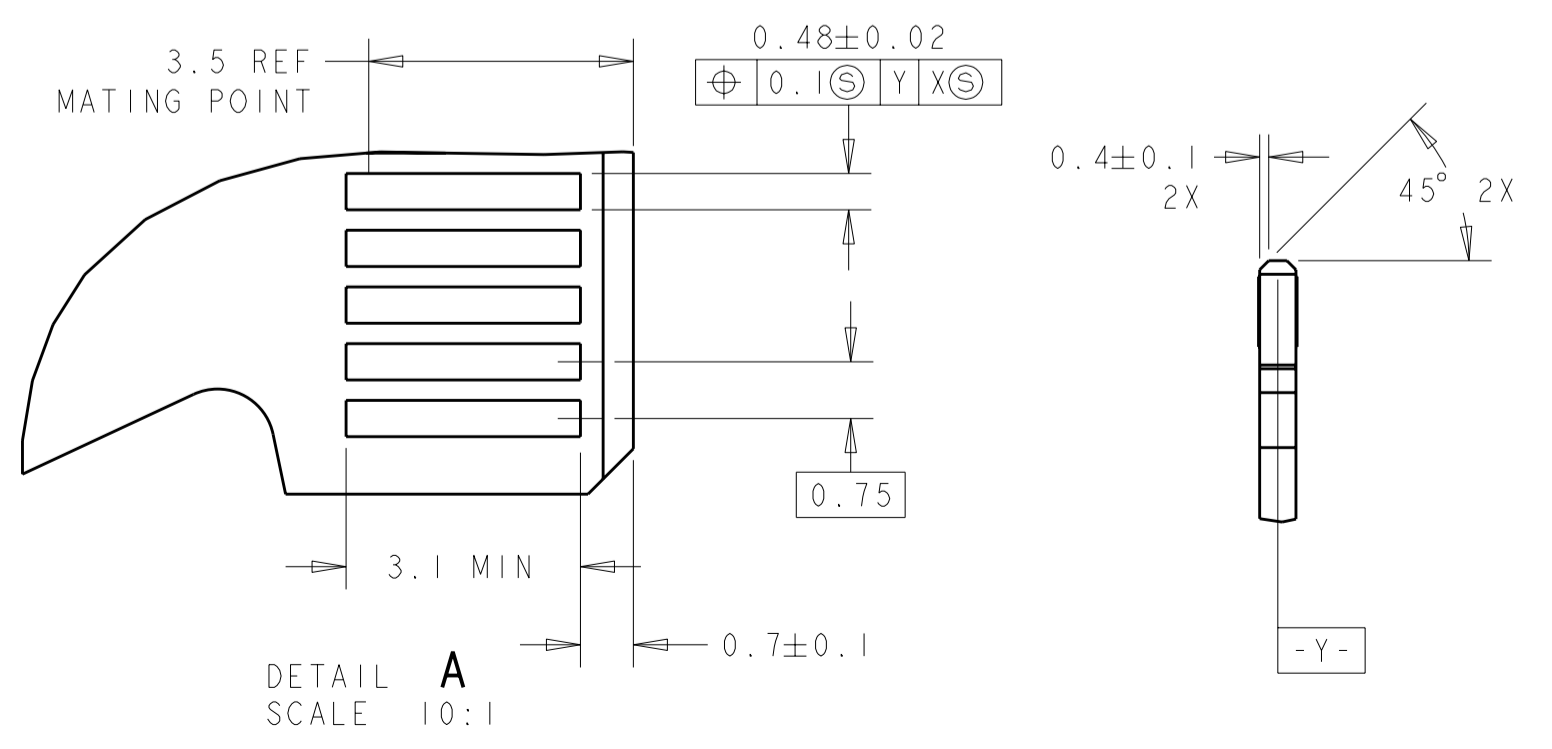

31.50	63.00	65.00	85	170
25.88	51.75	53.75	70	140
22.50	45.00	47.00	61	122
20.25	40.50	42.50	55	110
14.63	29.25	31.25	40	80
9.00	18.00	20.00	25	50
"C"	"B"	"A"	PADS PER SIDE	CONNECTOR SIZE

THIS DRAWING IS A CONTROLLED DOCUMENT FOR TYCO ELECTRONICS CORPORATION. IT IS SUBJECT TO CHANGE AND THE CONTROLLING ENGINEERING ORGANIZATION SHOULD BE CONTACTED FOR THE LATEST REVISION.

DWN: D. SZCZESNY 11 JAN 08
 CHK: -
 APVD: -
 PRODUCT SPEC: 108-2254
 APPLICATION SPEC: 114-13180
 MATERIAL: -
 FINISH: -
 WEIGHT: -
 CUSTOMER DRAWING

TOLERANCES UNLESS OTHERWISE SPECIFIED:
 0 PLC ± 0.1
 1 PLC ± 0.5
 2 PLC ± 0.13
 3 PLC ± 0.013
 4 PLC ± 0.0001
 ANGLES ±

Tyco Electronics
 Harrisburg, PA 17105-3608

NAME: CARD EDGE CONNECTOR, VERTICAL
 0.75 CENTERLINE

SIZE: A2
 CAGE CODE: 200779
 DRAWING NO: C-1934768
 RESTRICTED TO: -

SCALE: 2:1
 SHEET: 4 OF 4
 REV: B

单击下面可查看定价，库存，交付和生命周期等信息

[>>TE Connectivity\(泰科\)](#)