

THIS DRAWING IS UNPUBLISHED. RELEASED FOR PUBLICATION
 © COPYRIGHT - By - ALL RIGHTS RESERVED.

LOC	DIST	REVISIONS					
		P	LTR	DESCRIPTION	DATE	DWN	APVD
AF	50		T1	REVISED PER ECO-11-004587	11MAR11	RK	HMR

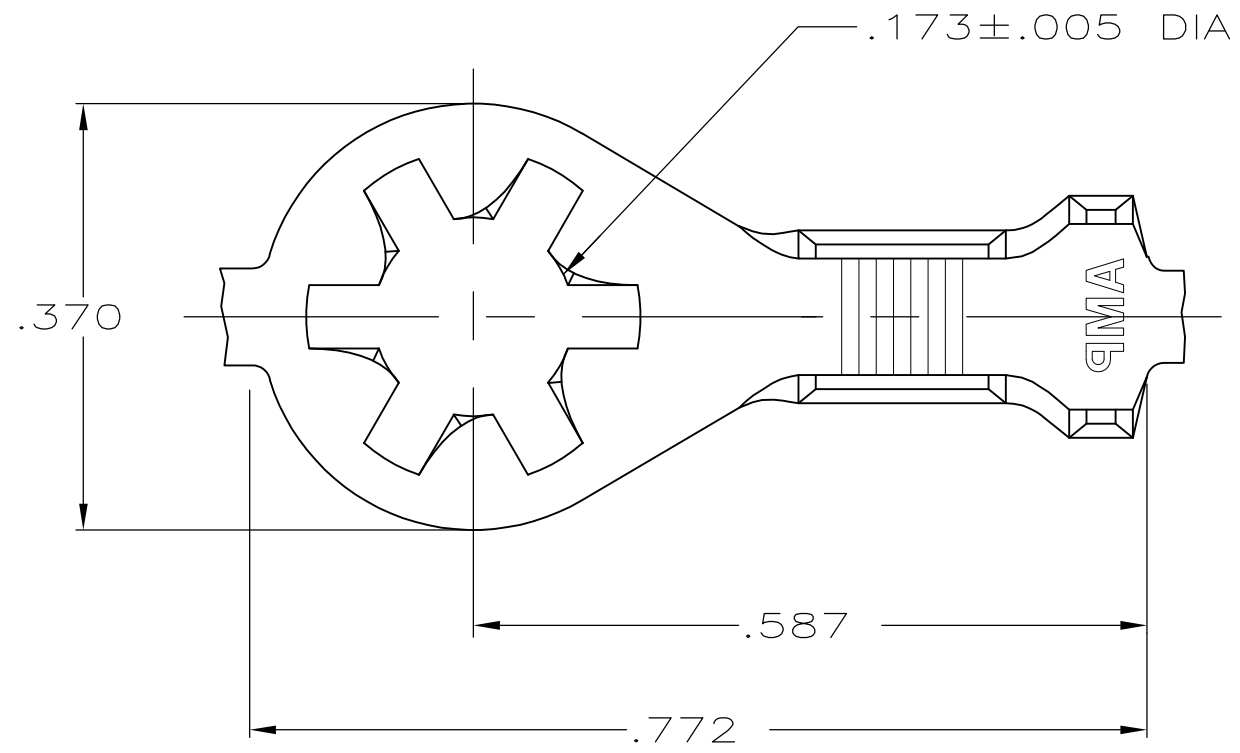

- 1 CONTINUOUS STRIP ON REELS
- 2 REELED WITH PAPER
- 3 .000080 MIN TIN PL PER MIL-T-10727.
- 4 PRELIMINARY - NOT FOR PRODUCTION

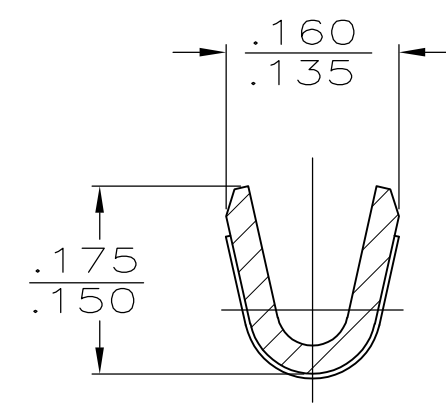

SECTION B-B

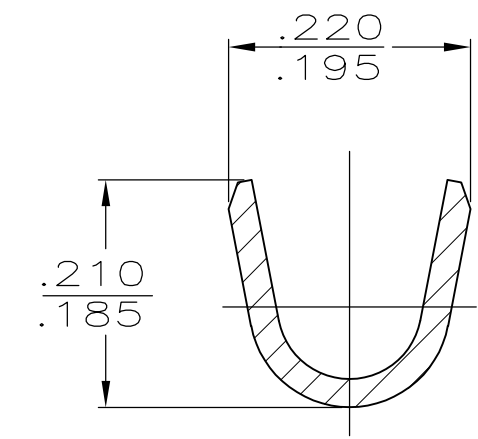

SECTION C-C

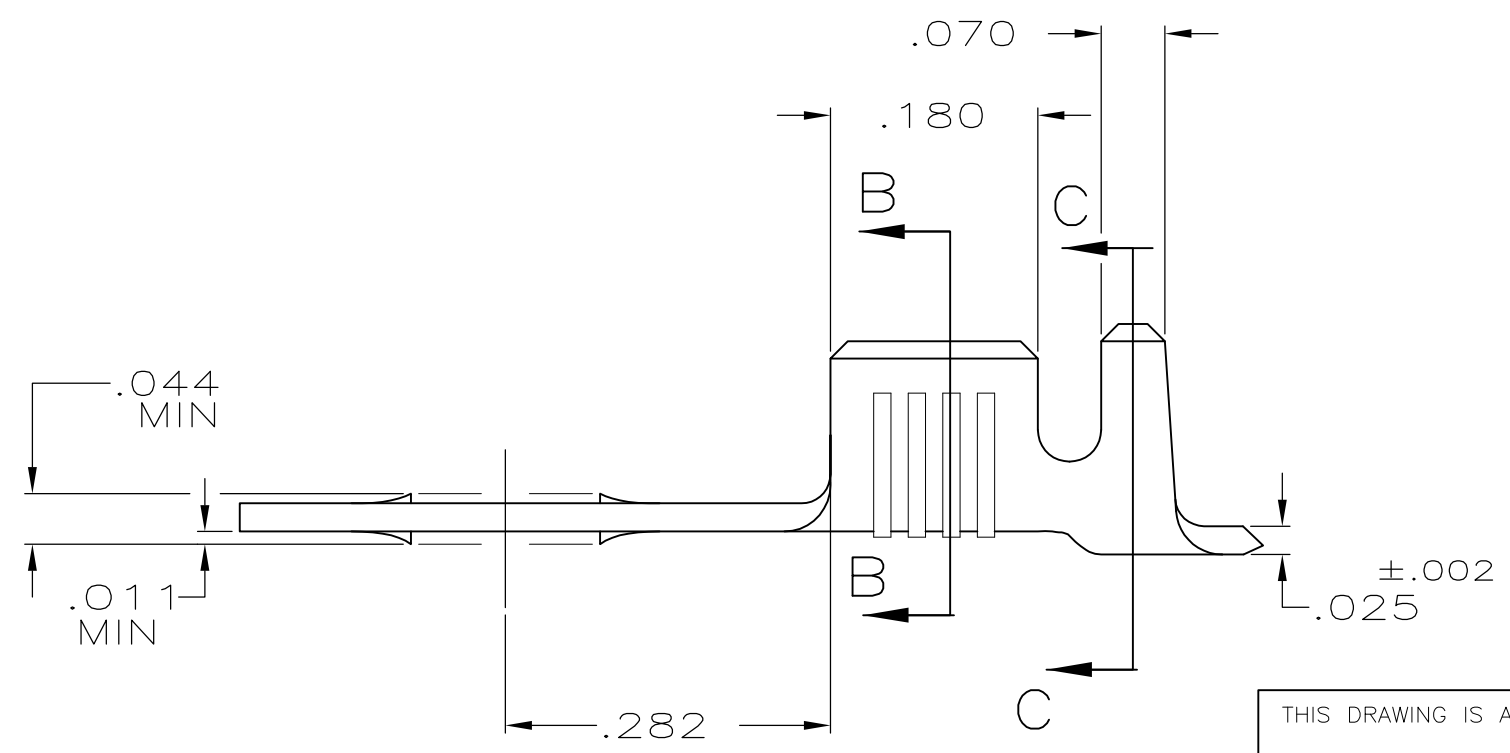

4	3	T4 BRASS	.105-.145	18-14	61794-7
2	3	T2 STEEL	.105-.145	18-14	61794-6
		T4 BRASS	.105-.145	18-14	61794-4
OBSOLETE		NICKEL PL T2 STEEL	.105-.145	18-14	61794-3
OBSOLETE					61794-2
	3	T2 STEEL	.105-.145	18-14	61794-1
FINISH		MATERIAL	INSULATION RANGE	WIRE SIZE	PART NO

THIS DRAWING IS A CONTROLLED DOCUMENT.

DWN	D HOLLINGSWORTH	5/15/87	 TE Connectivity	RING		
CHK	G YETTER	11/23/87				
APVD	RP FRANTZ	12/2/87				
PRODUCT SPEC						
APPLICATION SPEC			SIZE	CAGE CODE	DRAWING NO	RESTRICTED TO
WEIGHT	-		A3	00779	C-61794	-
CUSTOMER DRAWING			SCALE	SHEET	REV	
			6:1	1 OF 1	T1	

DIMENSIONS:	TOLERANCES UNLESS OTHERWISE SPECIFIED:
INCHES	
	0 PLC ± -
	1 PLC ± -
	2 PLC ± -
	3 PLC ± .015
	4 PLC ± -
	ANGLES ± -
MATERIAL	FINISH
SEE TABLE	SEE TABLE

单击下面可查看定价，库存，交付和生命周期等信息

[>>TE Connectivity\(泰科\)](#)