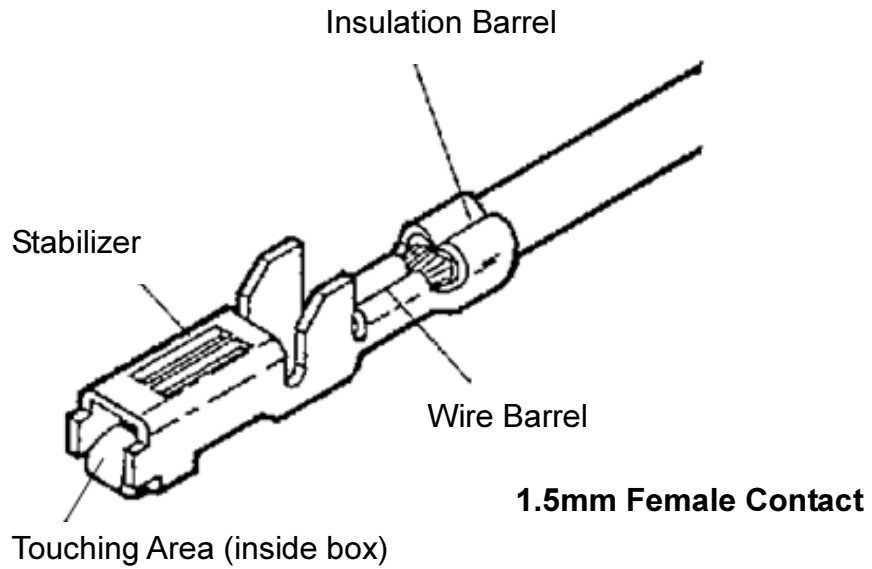

16POS DIAGNOSTIC CONNECTOR

| CONTENTS | Page |
|---|-------------|
| 1. Product Name and Part Number | 2 |
| 1.1 Contact | 2 |
| 1.2 Housing | 2 |
| 1.3 Part Number | 3 |
| | |
| 2. Inspection of Contact and Housing | 3 |
| 2.1 TE's Shipping Inspection..... | 3 |
| 2.2 Customer's Receiving Inspection..... | 4 |
| | |
| 3. Crimping Operation | 5 |
| 3.1 Control of Storage and Transfer | 5 |
| 3.2 Control of Crimping Operation..... | 6 |
| 3.3 Control of Crimped In-Process Products | 9 |
| | |
| 4. Manufacturing Harness Assemblies | 10 |
| 4.1 Mating Contact into Housing and Complete of Doublelock..... | 10 |
| 4.2 Extract of Contact | 12 |
| 4.3 Dealing with Harness Products | 13 |
| | |
| 5. Assembling on Vehicles | 14 |
| 5.1 Receiving Inspection..... | 14 |
| 5.2 Points of Mating Operation..... | 14 |
| 5.3 Caution | 14 |

1 Product Name and Part Number

This product is called 16position Diagnostic Connector and composed of following parts.

1.1 Contact



1.2 Housing

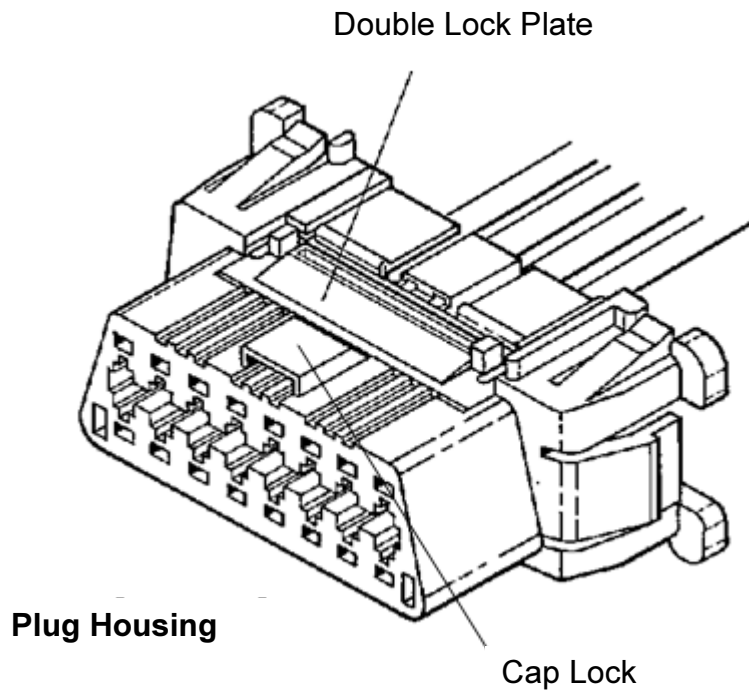

1.3 Part Number

1.3.1 Contact

| Name | TE Number | Applicable Wire | | | |
|----------------------|-----------|-----------------|-----|-----|------|
| | | Wire Type | 0.3 | 0.5 | 0.85 |
| 1.5mm Female Contact | 776001 | CAVUS | ○ | ○ | ○ |
| | | CAVS/AVSS | ○ | ○ | ○ |
| | | AVS | ○ | ○ | ○ |

1.3.2 Housing

| Pos. | Name | Number |
|------|--------------------|--------|
| 16 | 16Pos.Plug Housing | 179631 |

2 Inspection of Contact and Housing

2.1 TE's Shipping Inspection

Prior to shipping, products are thoroughly inspected by TE in accordance with the self-specified quality control procedures and regulations to cover all the data of manufactures by each lot production. Date of manufacturing is shown on the wrapping so that the process of manufacturing can be traced referring to the records of inspection, manufacturing and machinery control.

Date of manufacturing is shown like follows.

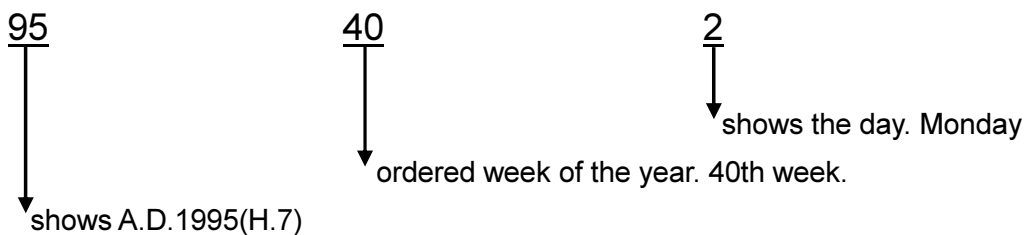

2.2 Customer’s Receiving Inspection

Also, it is desirable that products are at least inspected referring to the applied customer drawing as receiving inspection. Please follow the method below.

〈Contact〉

| Item | Inspection Regulation and Method | Tools for Measurement |
|-----------------------|--|-----------------------|
| Appearance Inspection | 1) Shape | Visual |
| | 2) Plate Finishing | Visual |
| | 3) Condition of Strip Terminals | Visual |
| Size Inspection | 1) Width and Height of Wire Barrel | Callipers |
| | 2) Width and Height of Insulation Barrel | Callipers |

In receiving, whole reels must be cut apart by Date Code as Reeling unit, visually inspected on II (MIL-STD-105) standard and AQL4%, also inspect the five edge points of the reels. When the all five reels meet the standard, the lot is supposed to have passed the inspection.

〈Housing〉

| Item | Inspection Regulation and Method | Tools for Measurement |
|-----------------------|---|-----------------------|
| Appearance Inspection | 1) Burrs, Discoloration and Deformation | Visual |
| | 2) Cracking, Breakage and Tip-Off of Housing | Visual |
| Functional Inspection | 1) Mating and Unmating Function of Contacts; Check to see if the housing is normally mated and unmated, and locked when mated. Unmating must be easily done by pressing unlocking leg and pulling it out. | Manual |

Set one wrapped as box one unit, classify the boxes by Date Code, inspect their appearance in accordance with II (MIL-STD-105) standard and AQL4%, then give a functional inspection to five of them. When the all housings meet these standards, the lot is supposed to have passed the inspection.

3. Crimping Operation

Crimping of Contacts must be done with TE specified application tools following the specified procedure. Also, it is recommended to record the part number and date code (see already specified example; 95402) for future reference.

3.1 Storage and Transfer of Reeled Products

- 1) Avoid Carrying or leaving terminal reel in an open area without wrapping it with proper material.
- 2) Do not lift up or carry the terminal reel by gripping only one flange of the reel lest it should cause the damage of the reel and become unable to be used on crimping machine.

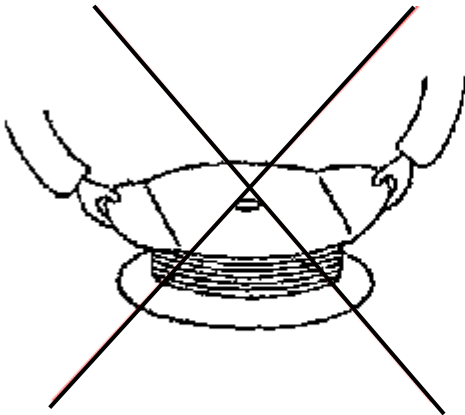

Do not hold only one side rim of the reel



CORRECT

- 3) Avoid leaving terminal reels in a damped area. Store them at where relatively dry and clean room without direct sunlight with the appropriate temperature 5~35°C and the humidity 45~85%.
- 4) When the terminal reel is not in use for a long time, discharge it from the machine, and fasten the end of terminal strip on the edge of reel with the proper string or wire as shown in the figure below.

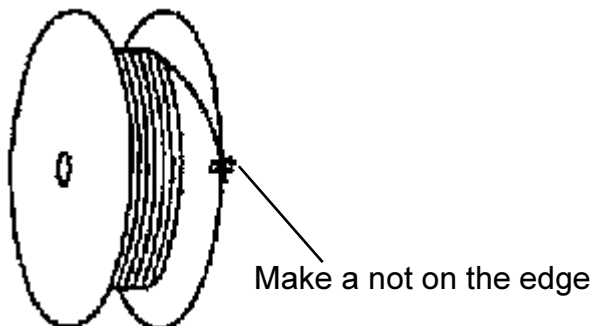

Make a not on the edge

3.2 Control of Crimping Operation

It is required to prepare the Instruction Manual following the Application Specification 114-2136. Important points are listed below.

(1) Wires must not be damaged or severed

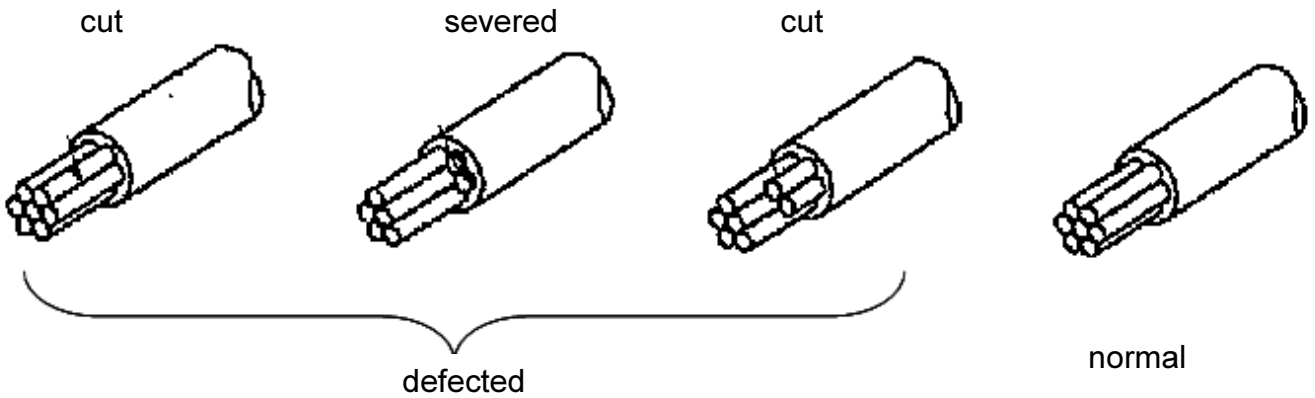

(2) Wire end pre-treatment before Crimping

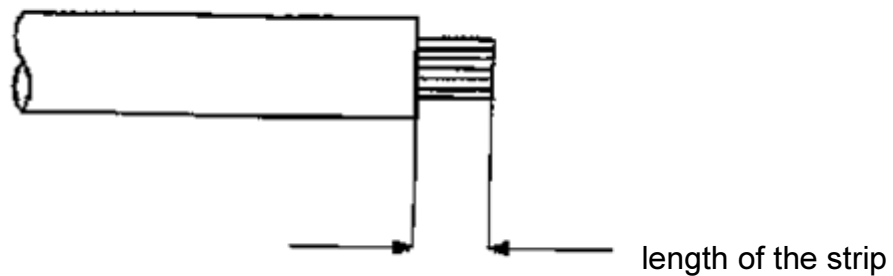

appropriate length: the length of wire barrel of used contact +0.5~1.0mm

(3) Cross-section of Wire Barrel Crimp

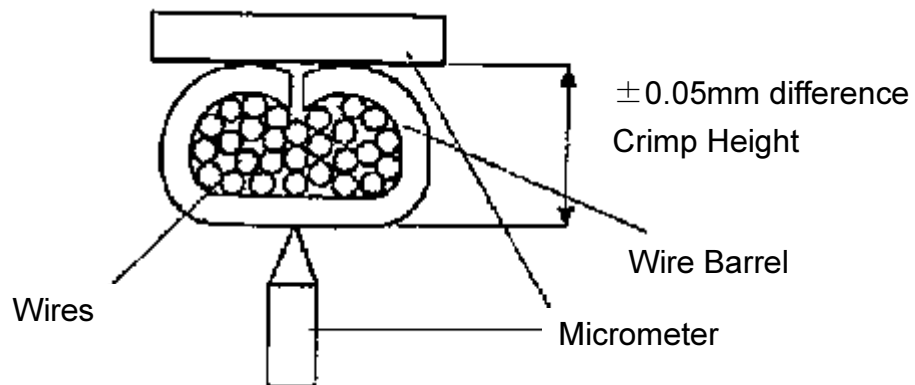

(4) Modified Micrometer for Measurement of Crimp Height

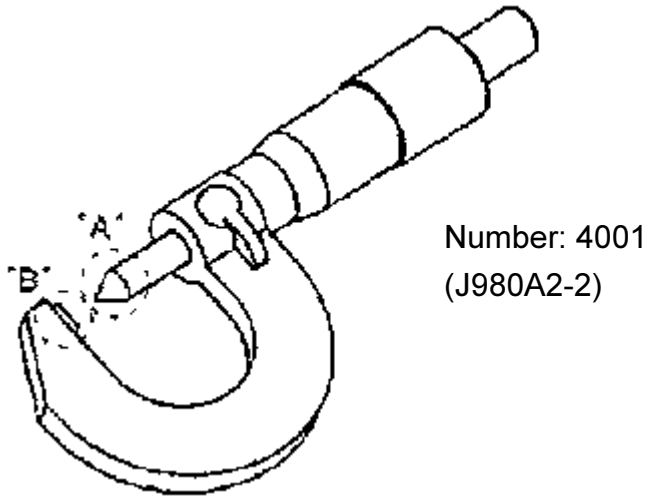

3.2.1 Crimping Condition of Contact

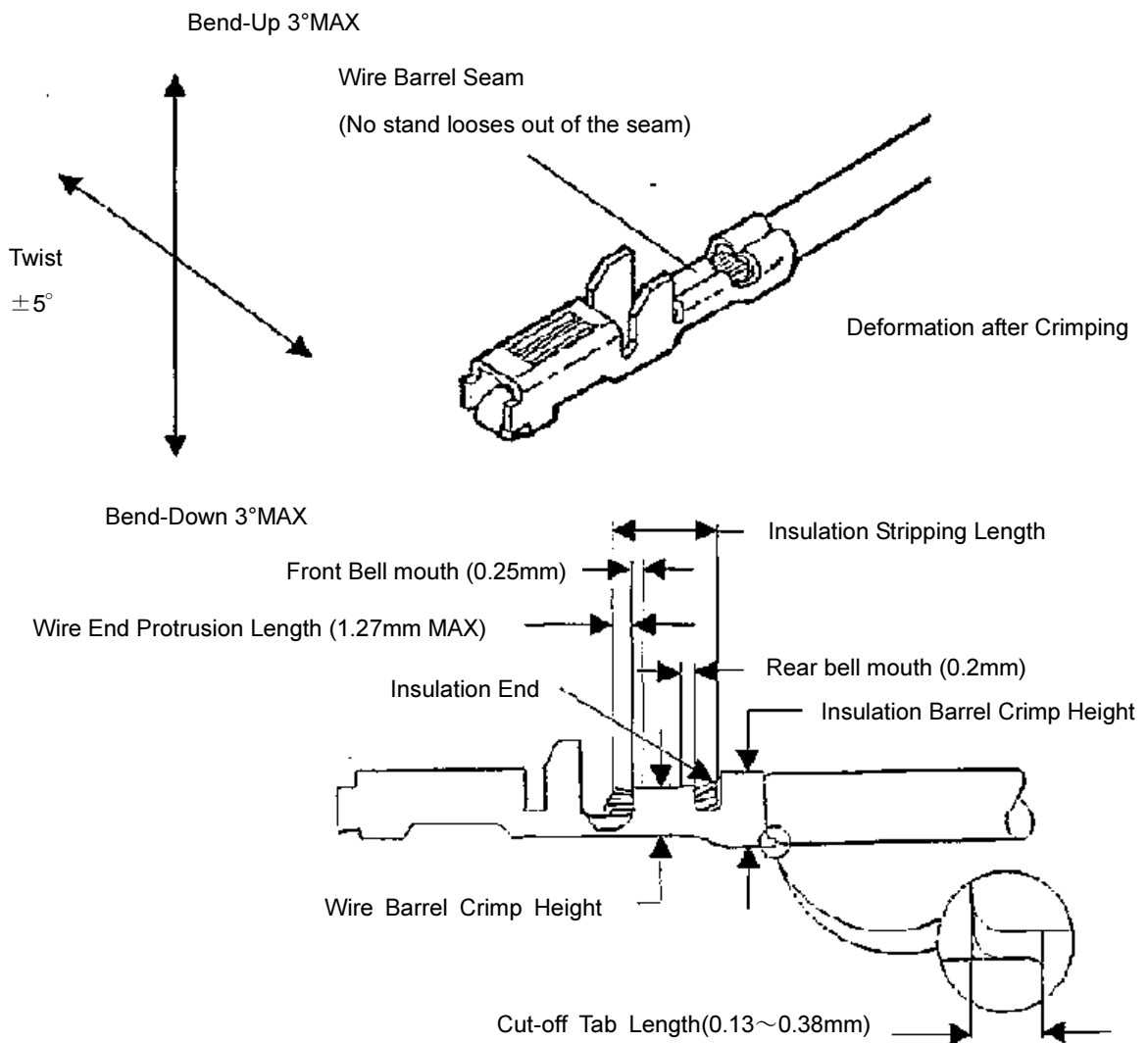

3.2.2 Crimping Data (1.5mm Series)

Applicator No. to crimp contacts and the sizes are follows. Please have a check before the operation.

| Contact No. | Applicator No. | Wire Size | Wire Barrel Crimp | | Inspection Items | |
|-------------|----------------|-----------|-------------------|-------------|------------------|-------------|
| | | | Width (mm) | Height (mm) | Width (mm) | Height (mm) |
| 776001 | 567467-2 | 0.3 | 1.78 | 1.07 | 2.34 | 2.46max |
| | | 0.5 | | 1.15 | | |
| | | 0.85 | | 1.24 | | |

*: Applicable wires are Automotive Low Voltage ones. AVS/AVSS/CAVUS 0.3~0.85

3.3 Control of Crimped In-Process Products

3.3.1 Inspection of Products

Inspection of crimped in-process products must be conducted by the lot unit, which means the group of products manufactured under the same set-up adjustment of the crimping machine or that of products manufactured during whole one day. The inspection must be conducted under the same condition.

Refer to the list below the details.

| Type of Inspection | Timing | Inspection Items |
|--|---|--|
| Inspection on Products made under initial set-up condition of applicator | When the first applicator is set up on the wire | Visual Inspection and Dimensional Inspection of all items listed below |
| Lot Inspection | Beginning of the operation everyday | Same as above |
| | During the continuous production run | Visual Inspection on all the items listed below, and Dimensional Inspection only on the Item No.3 in following chart |

| Type of Inspection | Checking Points and Methods | Tools for Measurement |
|--------------------|---|-----------------------|
| Visual Inspection | 1.Loose-out of wire conductors outside the wire barrel crimp, and cut-off of conductor(s) | Visual |
| | 2.Defective crimped form of contact (forming up of bellmouth, and wire end protrusion length) | Visual |
| | 3.Defective wire barrel at the bottom(burrs appearing, inclusive) | Visual |
| | 4.Misgripping of insulation barrel crimp on wire insulation | Visual |
| | 5.Deformation of contacting area of contact | Visual |
| Size Inspection | 1.The length of Cut-Off Tab 0.13~0.38mm | Callipers |
| | 2.Deformation of Contact (bend-up, rolling, and twisting) | Magnifying Glass |
| | 3.Crimp Height | Micrometer |
| | 4.Front and rear of bellmouth forming Front bellmouth:0.2mm max Rear bellmouth: 0.5mm max | Callipers |

*Note: Callipers are defined as vernier callipers or equivalent measuring tools, having the identical precise measurement level.

3.2.2 Storage

- a) Products must be kept in the clean, dry area. Exposing in the open air until the following day is strictly forbidden for the prevention from contamination by dust and particle.
- b) Maximum 100 of in-process crimped leads to bundle.
- c) Avoid stacking and piling up of the in-process products in large volume, lest it should result in catching each other and entangling on the projecting parts of the leads. This will cause damage and breakage of the products. Deformation of the contact will result in malfunction of contacting parts electrically.
- d) Beware in separating bundles not to get contacts entangled.
- e) Do not leave uncrimped contacts in the damp place. Contacts must be kept in suitably dry sunshined clean room with the appropriate temperature (5~35°C) and the humidity (45~85%)
- f) Beware in string or transferring bundles of crimped contacts lest they should be entangled or deformed. Maximum 100 of contacts to bundle.

4. Manufacturing Harness Assemblies

4.1 Mating Contact into Housing and Complete of Doublelock

4.1.1 Loading Contact

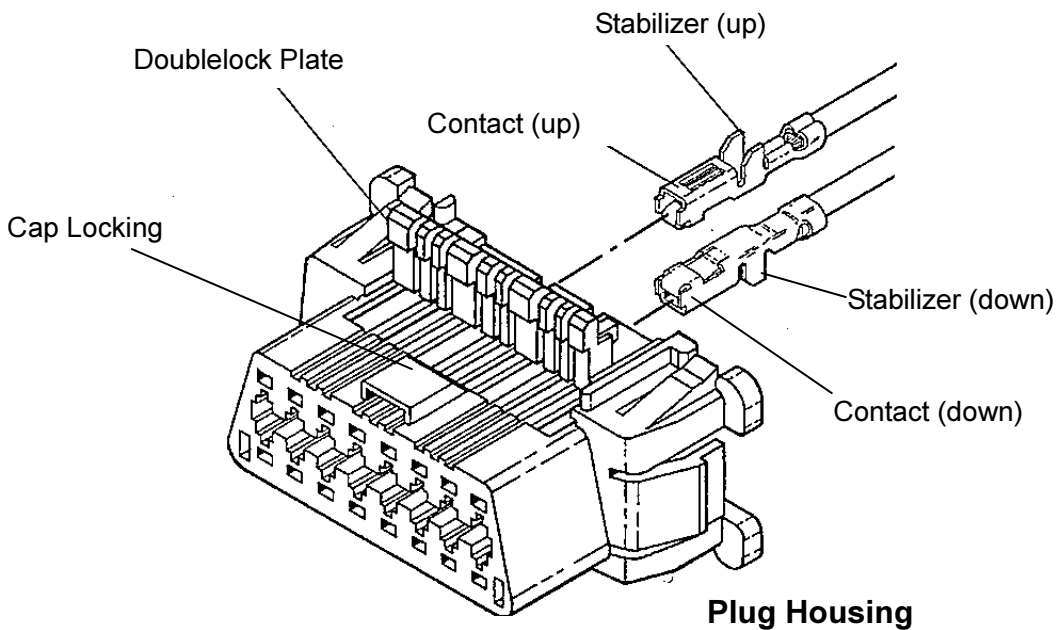

Direction of Contact

Direction of Contact is distinguished from that of stabilizer.

Place the housing with its cap locking side up (without shorter side of trapezoid up), stabilizer of upper contact side up, and that of lower down. Load the contact following the instructions below.

- (1) Please make certain of direction of contact and insert contact into housing until it clicks and does not go further. Also pull the wire lightly and make sure the contact does not come out.
- (2) In case contact must be taken out, beware of the deformation.
- (3) After the completion of loading contact, doublelock it as soon as possible.

4.1.2 Secondary Lock Operation

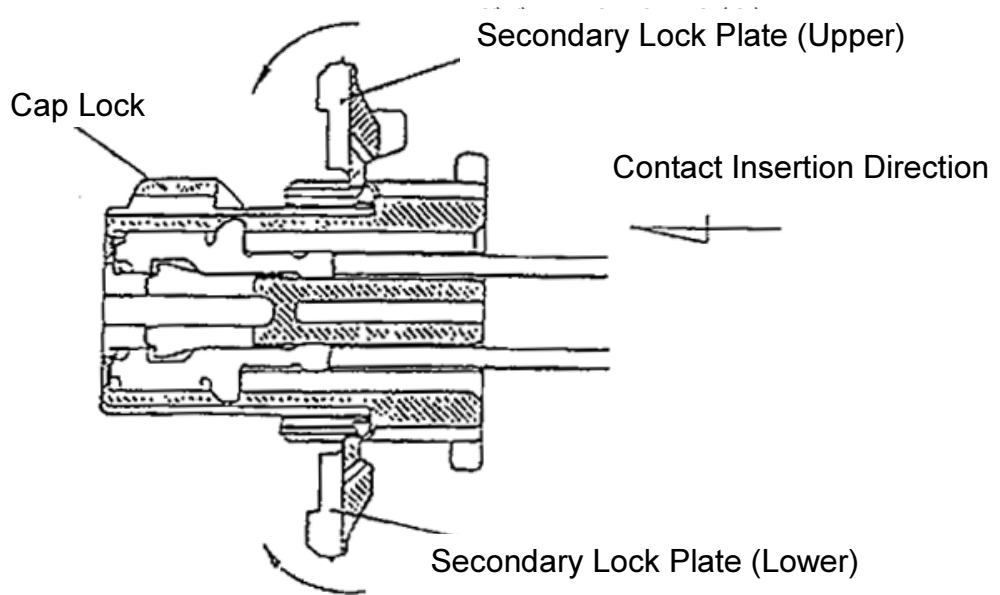

(1) After completing all contacts insertion, rotate each Secondary Lock Plate and then press both sides of Secondary Lock as shown two solid arrows in below figure at the same time until click sound is made.

(2) Confirm Secondary Lock Plate is set at plane as Housing surface. If the Plate and the surface are not on same plane, contact insertion operation may not be completed perfectly. In this case, DO NOT try to push the plate into Housing with force. It is necessary to check all contacts position if they are inserted up to proper depth.

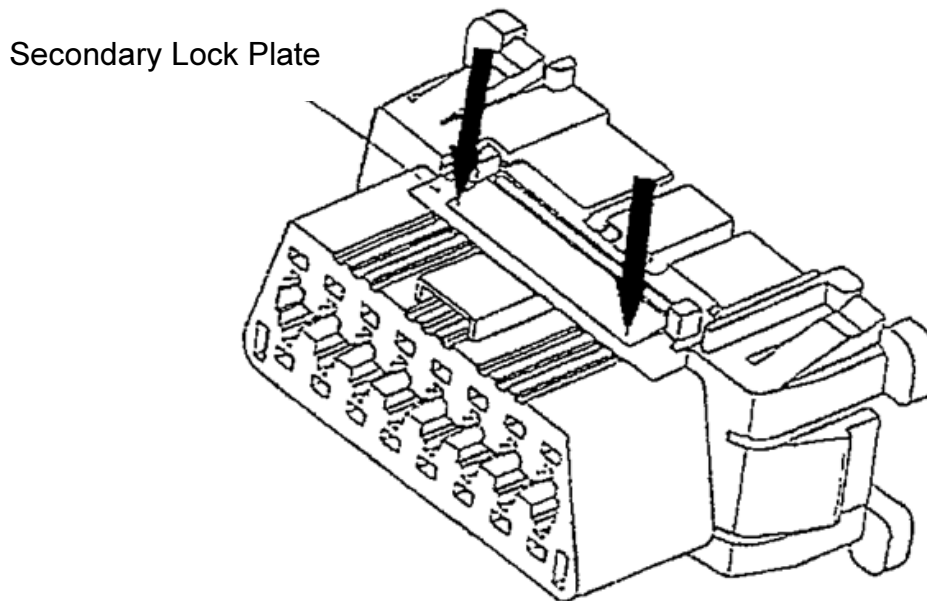

4.2 Extraction of Contact

4.2.1 Undoing of Doublelock

Lift up the Doublelock Plate with the tip of 1.2mm-width driver placed at the small holes (2holes: please note the tear drop mark to place the driver at.)

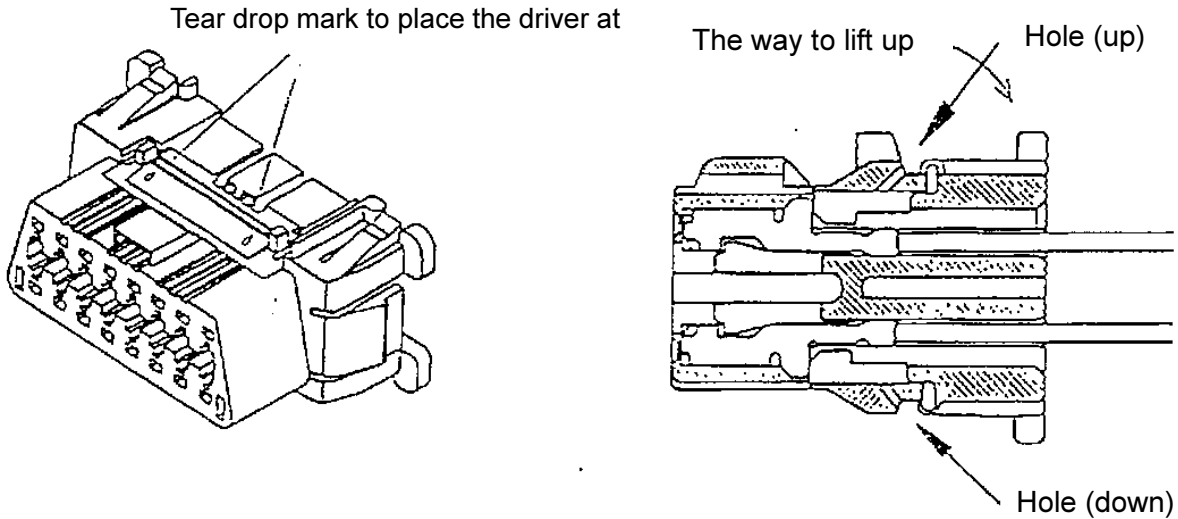

4.2.2 Extraction of Contact

In case the contact should be taken out from the hosing due to wrong wiring etc., release the doublelock first as shown above, then follow the instructions below.(use of 1.2mm-width driver is recommended))

- Do not insert any tool or driver into contacting area of contact lest it should damage the contact.
- If the contact become deformed by mistake, exchange contacts.

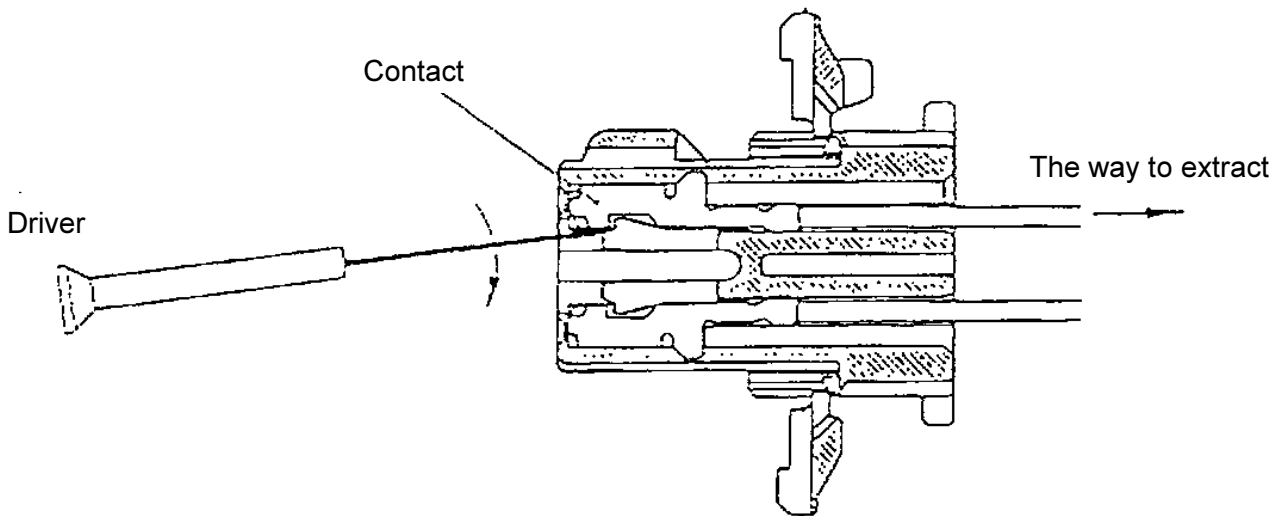

4.3 Control of Harness Products

4.3.1 Inspection of Harness

All Harness products are required to be inspected as inspection unit following the directions below.

- (1) As a checking probe for all the circuits of connectors, use the Mating Tab Contact or the tab that could substitute for it.
- (2) It is strictly forbidden at any case to insert the Inside Inspection Probe of Contact from the mating side lest it should damage its mating area, cast the probe from the wire side when necessary.

4.3.2 Storage

Products must be kept in the clean, dry area. Exposing in the open air through the following day is strictly forbidden for the prevention from contamination by dust and particles.

4.3.3 Delivery and Transfer

- (1) Products need appropriate dust and water-proof wrapping. Please handle with care.
- (2) Prescribed indications must be labeled.

5. Assembly on Vehicles

5.1 Receiving Inspection

For final receiving inspection, the following items are at least required to be inspected.

- (1) The bundling positions of leading wires in the housing.(more than 20mm when the wires are straight, 10mm when bent)
- (2) Mating condition of contact into housing.
- (3) Finishing of contact's surface, extreme discoloration, flaws and deformation.
- (4) Cracking, defects and discoloration on the housing.
- (5) Checking of defected products.

5.2 Check and Control on Assembly Operation

- (1) Conduct mating on one straight line and make sure the locking system has really worked. It clicks when it is locked properly. Also make certain of the complete of locking by pulling the connector forward lightly.
- (2) Avoid unnecessary repetition on of mating and unmating.
- (3) When the contact needs to be taken out from the housing, use the specified tool and follow the instructions at 4.2.
- (4) In checking the circuits, use the mating tab contact or the tab that could substitute for it.
- (5) Please handle harness with enough care and do not handle them like follows.
 - a) Throwing away
 - b) Dragging around on the floor
 - c) Carrying with holding connector
 - d) Causing inappropriate force on the connector by the wire pulling it.

5.3 Caution

Through this product is designed to bear the impact to some extent, the extra weight of the harnesses is added when it is fully mated due to its multi-positioning. Beware of the outside pressure and dropping impact during the operation, and take extreme care in transferring.

单击下面可查看定价，库存，交付和生命周期等信息

[>>TE Connectivity\(泰科\)](#)