

THIS DRAWING IS UNPUBLISHED.

RELEASED FOR PUBLICATION

ALL RIGHTS RESERVED.

© COPYRIGHT - By -

LOC	DIST	REVISIONS					
		P	LTR	DESCRIPTION	DATE	DWN	APVD
-	-		F4	REVISED PER ECR-21-102487	26APR2021	MK	EW

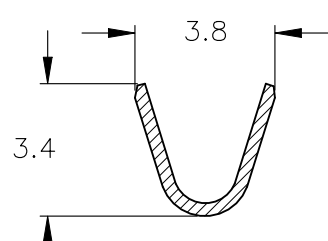
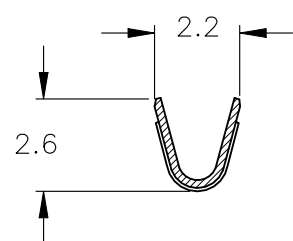
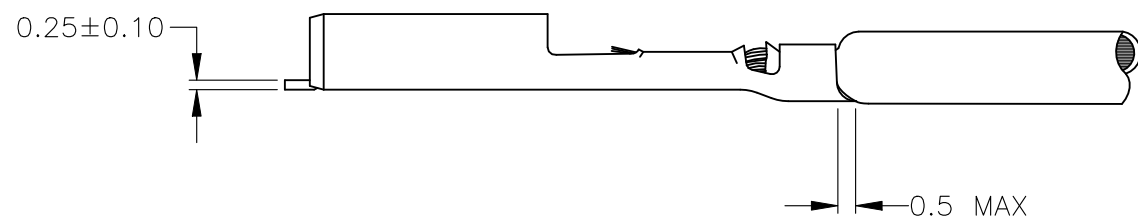
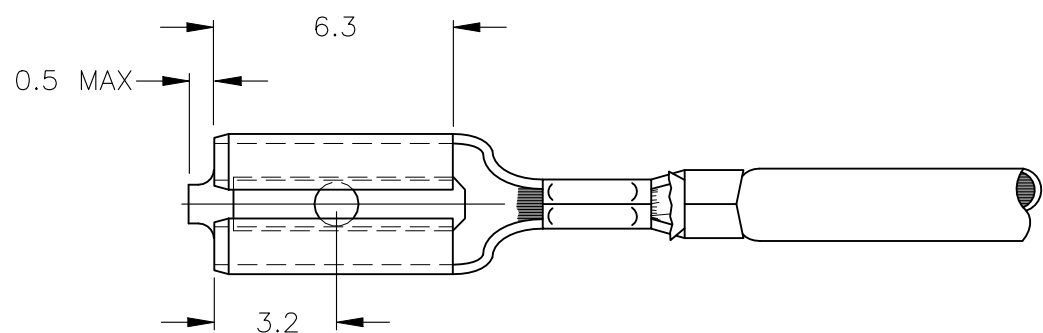
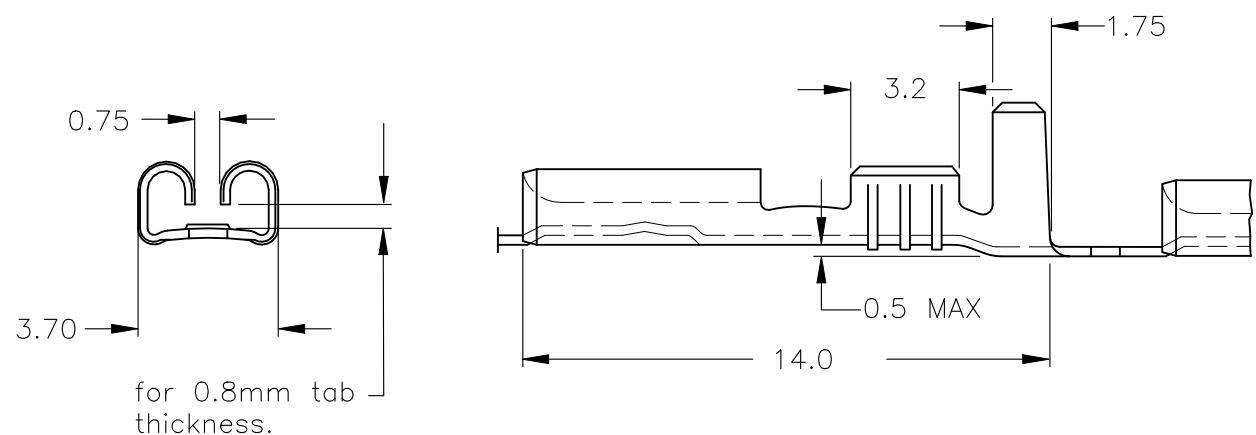
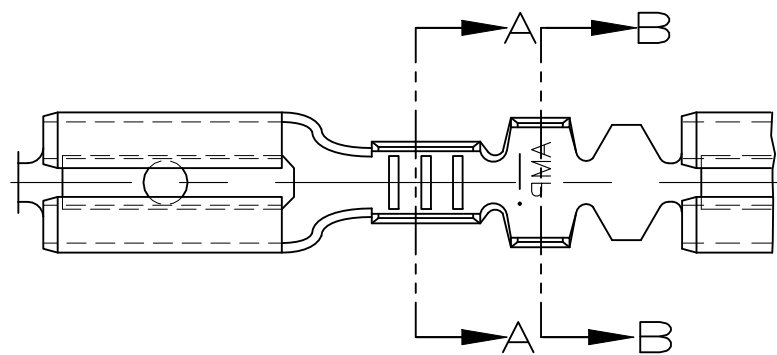

WIRE RANGE :
0.5-1.0 mm²
INSULATION RANGE :
2.0-3.0mm DIA.

DIRECTION OFF TOP OF REEL

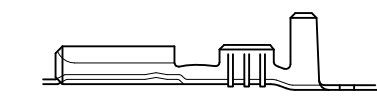

Terminal "U" up.

NOTES:

- 1 FOR USE ON MINIATURE APPLICATORS (LEFT-RIGHT FEED) AND STANDARD APPLICATORS (RIGHT-LEFT FEED).
- 2 FOR USE ON MINIATURE APPLICATORS (AMP-O-MATOR APPLICATION) (LEFT-RIGHT FEED).
- 3 REELED WITH PAPERCOVER.
- 4 OBSOLETE PARTS: OBSOLETE CIS STREAMLINING PER D.RENAUD/D.SINISI

NOTES	FINISH	MATERIAL	PART NUMBER
4 OBSOLETE	UNPLATED	PH.BRONZE	1-160534-1
	UNPLATED	BRASS	1-160534-0
	PRE-TINPLATED	PH.BRONZE	160534-9
4 OBSOLETE	UNPLATED	PH.BRONZE	160534-8
	TINPLATED	BRASS	160534-7
	UNPLATED	BRASS	160534-6
	PRE-TINPLATED	BRASS	160534-5
	UNPLATED	PH.BRONZE	160534-4
	SILVERPLATED	BRASS	160534-3
	TINPLATED	BRASS	160534-2
	UNPLATED	BRASS	160534-1

THIS DRAWING IS A CONTROLLED DOCUMENT.

DIMENSIONS: mm

TOLERANCES UNLESS OTHERWISE SPECIFIED:

0 PLC	± -
1 PLC	± 0.30
2 PLC	± 0.15
3 PLC	± -
4 PLC	± -
ANGLES	± -
FINISH	± -

MATERIAL SEE TABLE

SEE TABLE

DWN 08-04-92

J.V.D.HEIJDEN.

CHK A.BIJNEN.

APVD L.V.SOEST.

PRODUCT SPEC

APPLICATION SPEC

114-20109

WEIGHT -

CUSTOMER DRAWING

STE TE Connectivity

.110 SRS FASTON RECEPTACLE.

SIZE	CAGE CODE	DRAWING NO	RESTRICTED TO
A3	00779	C-160534	-

SCALE	SHEET	REV
-	1 OF 1	F4

单击下面可查看定价，库存，交付和生命周期等信息

[>>TE Connectivity\(泰科\)](#)