

THIS DRAWING IS UNPUBLISHED. RELEASED FOR PUBLICATION
 © COPYRIGHT - TE Connectivity Ltd. ALL RIGHTS RESERVED.

REVISIONS				
P	LTR	DESCRIPTION	DATE	APVD
	H	REVISED	21JUL2021	Y.O T.S

3-178129-6:AS SHOWN
 本図

NOTE
 1 MATERIAL:GLASS FIELD THERMO PLASTIC,POLYESTER
 COLOR;BLACK

注記
 1 材料: ガラス入り熱可塑性ポリエステル樹脂
 色: 黒色

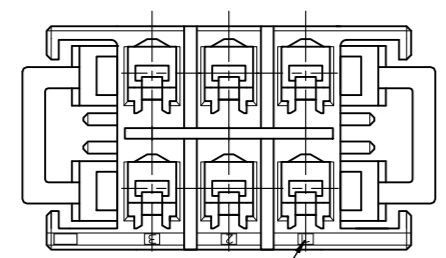
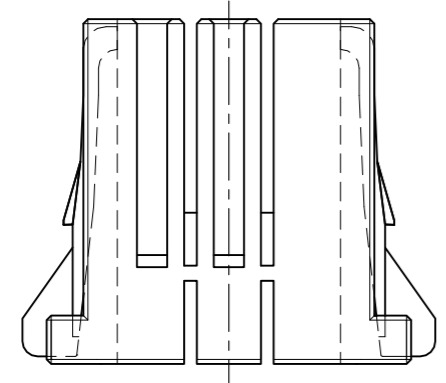
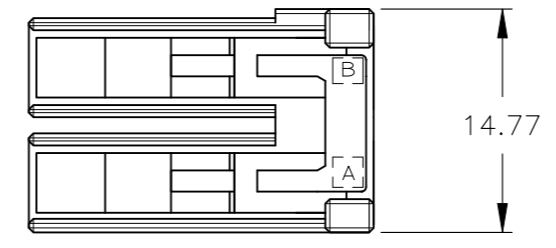
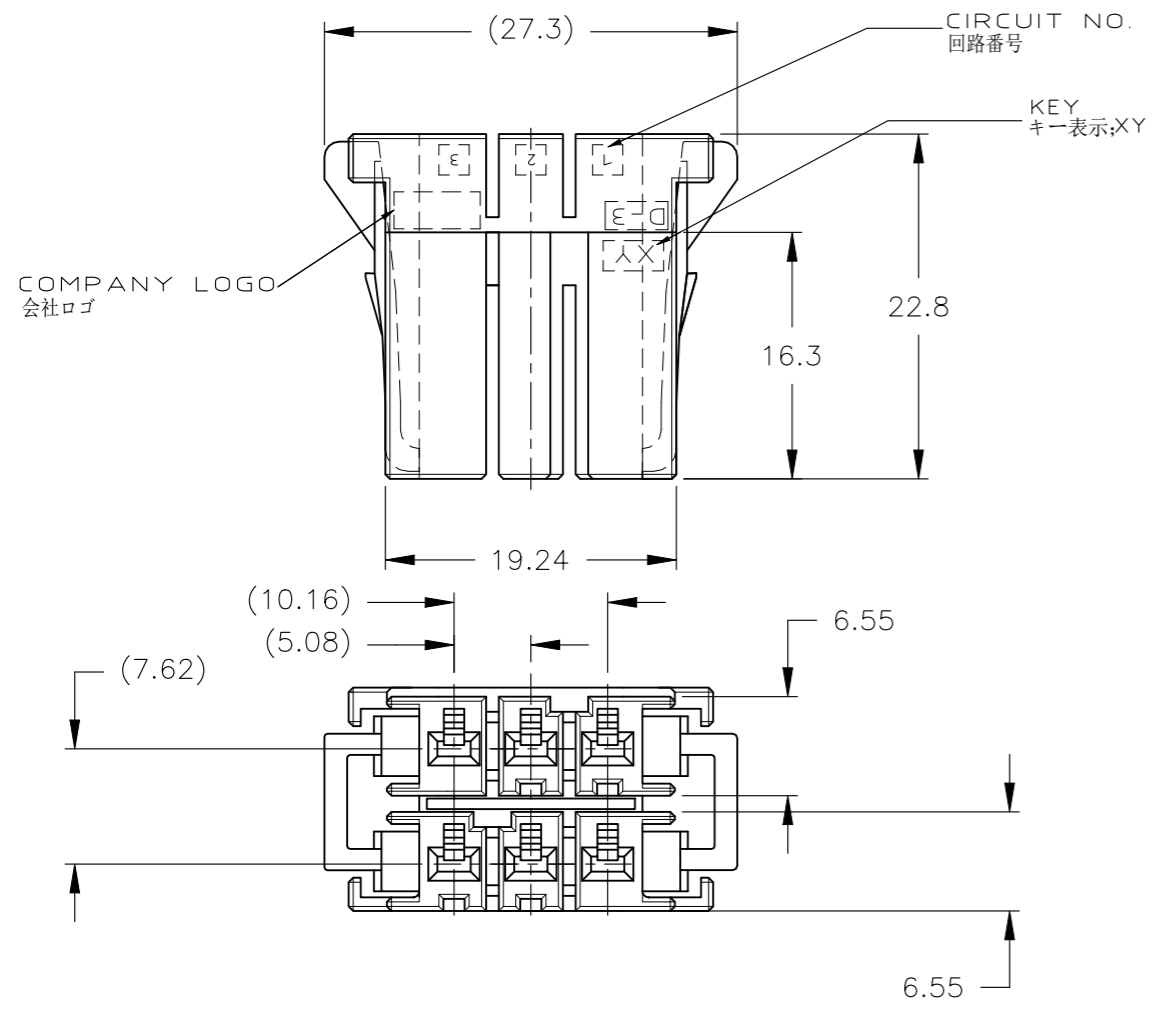

CIRCUIT NO.
 回路番号

-		XY	3-178129-6
-		YY	2-178129-6
-		XX	1-178129-6
FINISH	キーイングパターン KEYING PATTERN	キー KEY	型番 PART NUMBER

THIS DRAWING IS A CONTROLLED DOCUMENT.		DWN T.YONEBAYASHI 26/DEC/'89	TE Connectivity Ltd.	
DIMENSIONS: mm		CHK H.OBATA 23/JUL/'90		
TOLERANCES UNLESS OTHERWISE SPECIFIED: 10≥ : ±0.2 30≥ >10: ±0.25 100≥ >30: ±0.3		APVD S.MANABE 9/OCT/'90	NAME DYNAMIC D-3200,MODULAR TYPE 6POS. REC HSG	
		PRODUCT SPEC 108-5349	DRAWING NO C-178129	
MATERIAL 注記参照		FINISH -	APPLICATION SPEC -	RESTRICTED TO -
		WEIGHT	SIZE A3	CAGE CODE 00779
		CUSTOMER DRAWING	SCALE 1:1	SHEET 1 OF 1
				REV H

单击下面可查看定价，库存，交付和生命周期等信息

[>>TE Connectivity\(泰科\)](#)