

THIS DRAWING IS UNPUBLISHED. RELEASED FOR PUBLICATION
 © COPYRIGHT BY TYCO ELECTRONICS CORPORATION. ALL INTERNATIONAL RIGHTS RESERVED.

LOC	DIST	REVISIONS				
P	LTR	DESCRIPTION	DATE	DWN	APVD	
G	14	G	REV PER ECR-10-007973	16APRIL2010	RG	TM

AMP WIRE RANGE	Listed	LR7189 Certified
22-16 AWG SOLID OR STRANDED	22-16 AWG SOLID OR STRANDED	22-16 AWG SOLID OR STRANDED

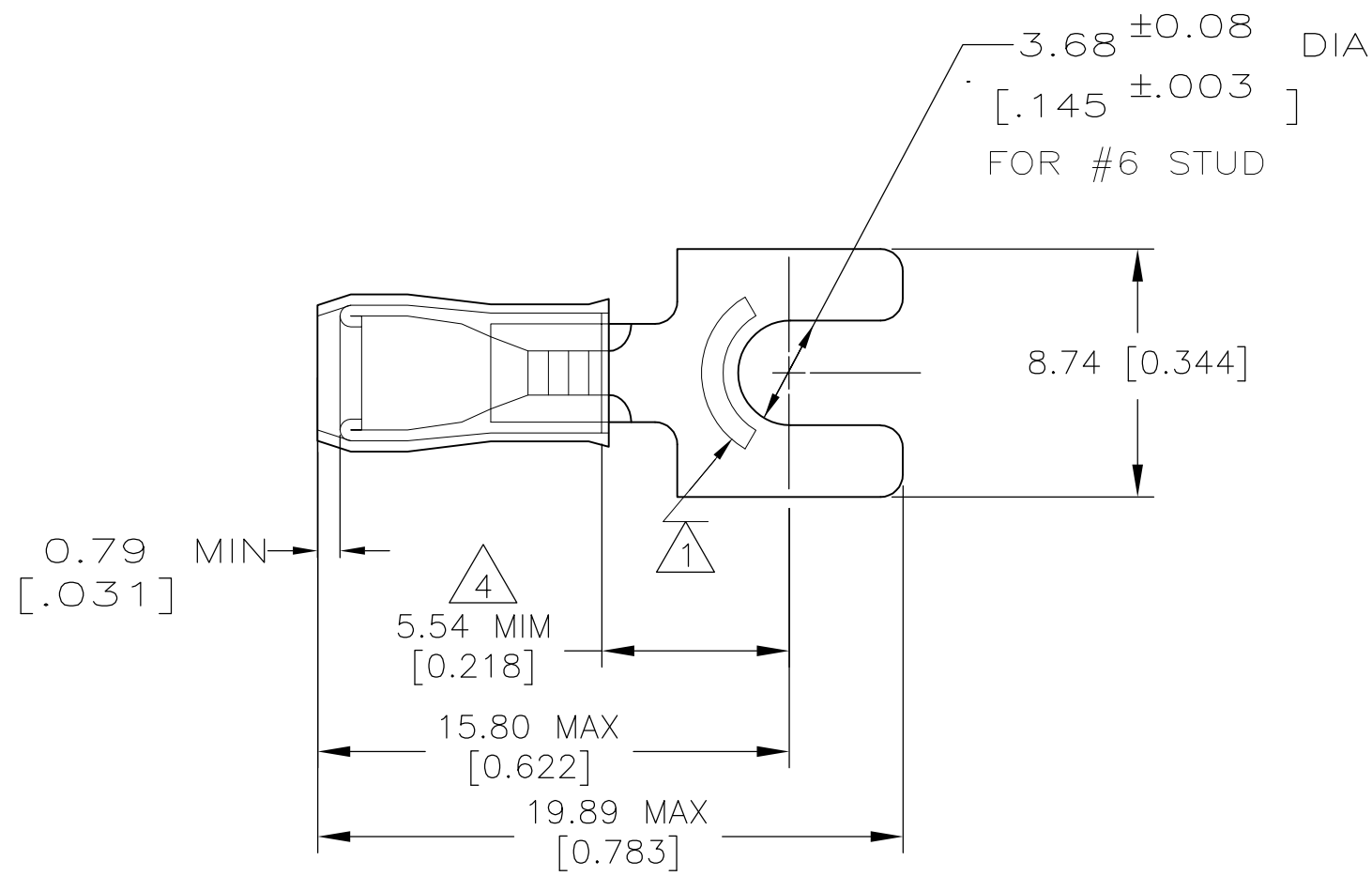

- 1 STAMP AMP 22-18* APPROX AS SHOWN
22-16 TERMINALS ARE STAMPED 22-18 IN
ACCORDANCE WITH MILITARY SPEC SAE-AS7928
COMMERCIAL WIRE RANGE IS 22-16
- 2 WIRE INSULATION DIA: .080 - .125
- 3 TONGUE MATERIAL THK: 0.79 ±0.05 [.031 ±.002]
- 4 APPLIES FROM EDGE OF METAL WIRE
BARREL TO CENTER OF STUD HOLE.
- 5. RECOMMENDED OPERATING TEMPERATURE: 105° C MAX
- 6. VOLTAGE RATING: 300 VOLT MAX
- 7. WIRE CROSS SECTIONAL AREA RANGE:
0.26 - 1.65mm² [5.09 - 3.260 CIRCULAR MIL AREA]
- 8 MATERIAL: COPPER PER ASTM B-152
- 9 FINISH: TIN PLATE PER ASTM-B545

1000	LOOSE PIECE	32403
QUANTITY	PACKAGE TYPE	PART NO.

THIS DRAWING IS A CONTROLLED DOCUMENT.		DWN 16APRIL2010 R.GRZYBOWSKI	Tyco Electronics Corporation Harrisburg, PA 17105-3608	
DIMENSIONS: INCHES		CHK 16APRIL2010 T.MICHIELUTTI		
TOLERANCES UNLESS OTHERWISE SPECIFIED:		APVD 16APRIL2010 M.PERCHERKE	NAME TERMINAL, SPADE TONGUE, PIDG, WIRE SIZE, 22-16 AWG	
0 PLC ± - 1 PLC ± - 2 PLC ± 0.20[.008] 3 PLC ± - 4 PLC ± - ANGLES ± -		PRODUCT SPEC UL 486A-486B	RESTRICTED TO	
MATERIAL		APPLICATION SPEC 114-2157	SIZE A3	CAGE CODE 00779
FINISH		WEIGHT -	DRAWING NO G-32403	REV G
-8		CUSTOMER DRAWING		SCALE 4:1
-9		SHEET 1 OF 1		

单击下面可查看定价，库存，交付和生命周期等信息

[>>TE Connectivity\(泰科\)](#)