

THIS DRAWING IS UNPUBLISHED. RELEASED FOR PUBLICATION  
 © COPYRIGHT BY TYCO ELECTRONICS CORPORATION. ALL RIGHTS RESERVED.

LOC	DIST	REVISIONS					
GP	00	P	LTR	DESCRIPTION	DATE	DWN	APVD
		0		RELEASED PER EC OS11-0045-05	15DEC05	BM	JGH

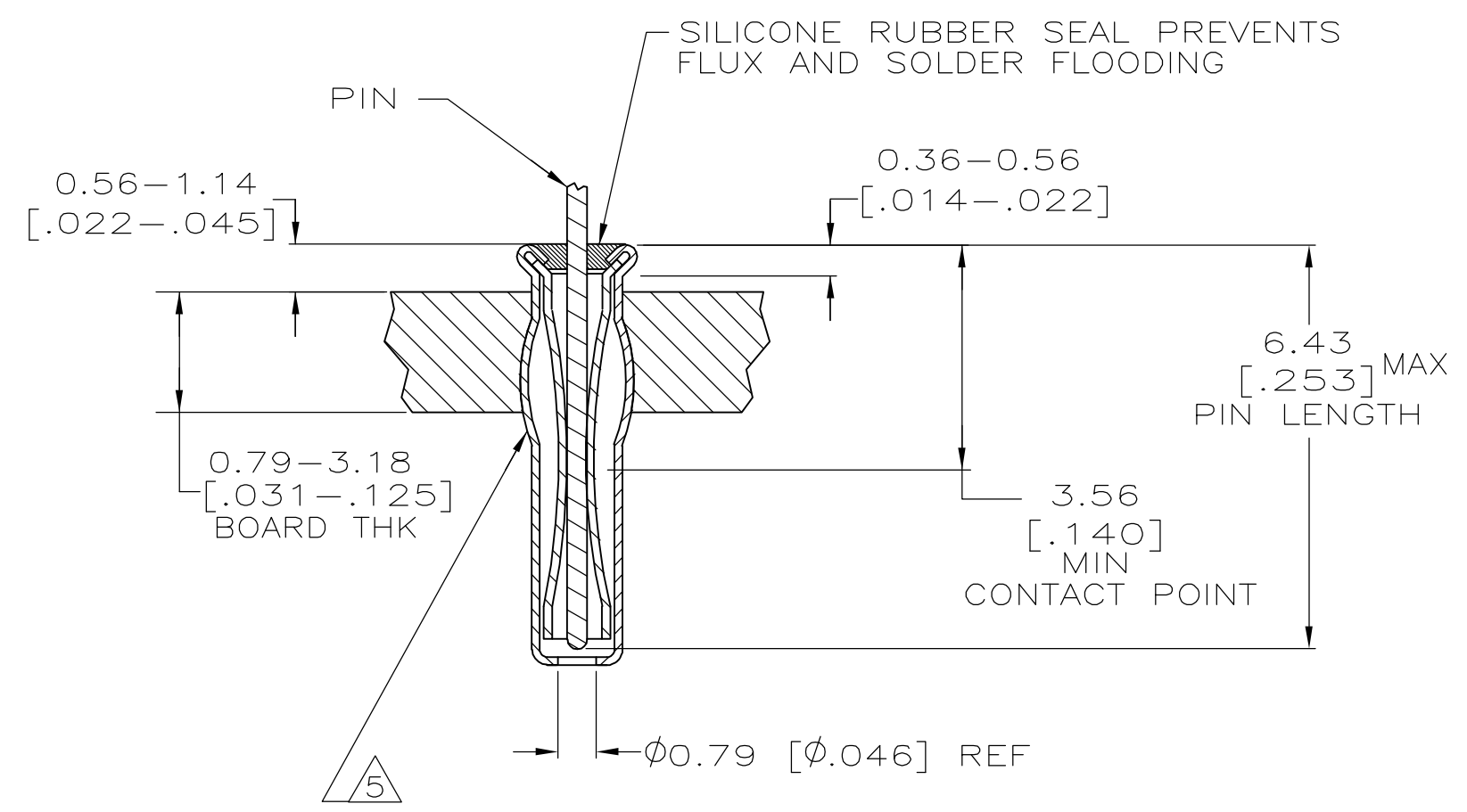
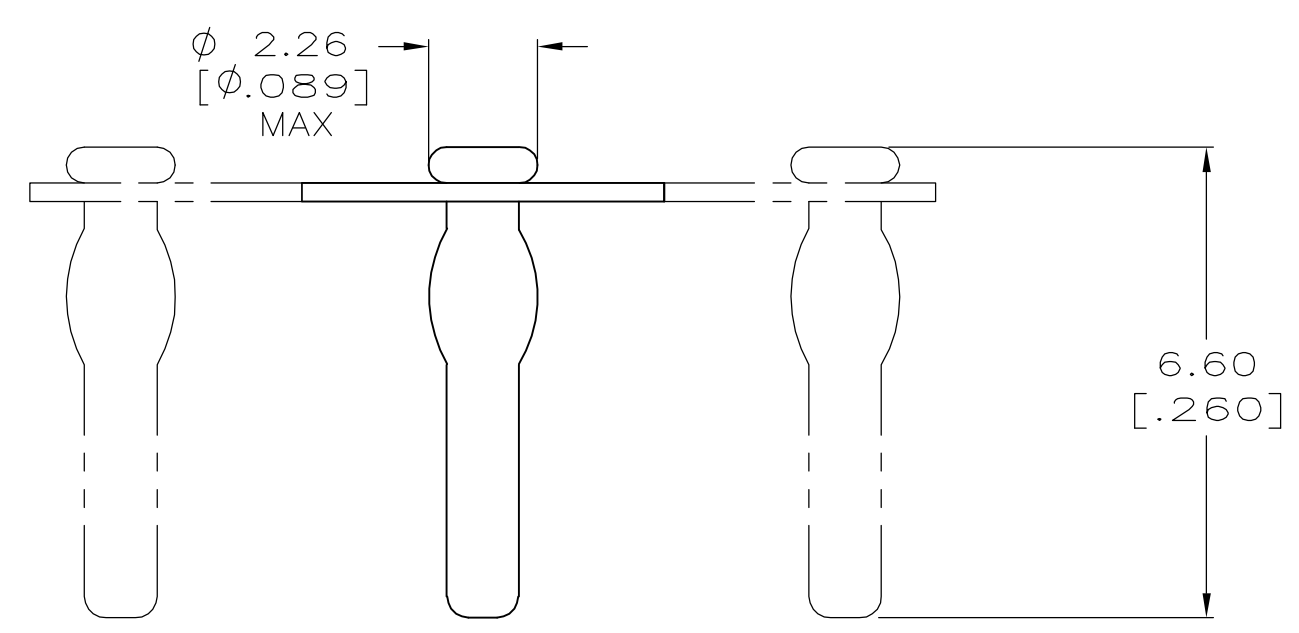
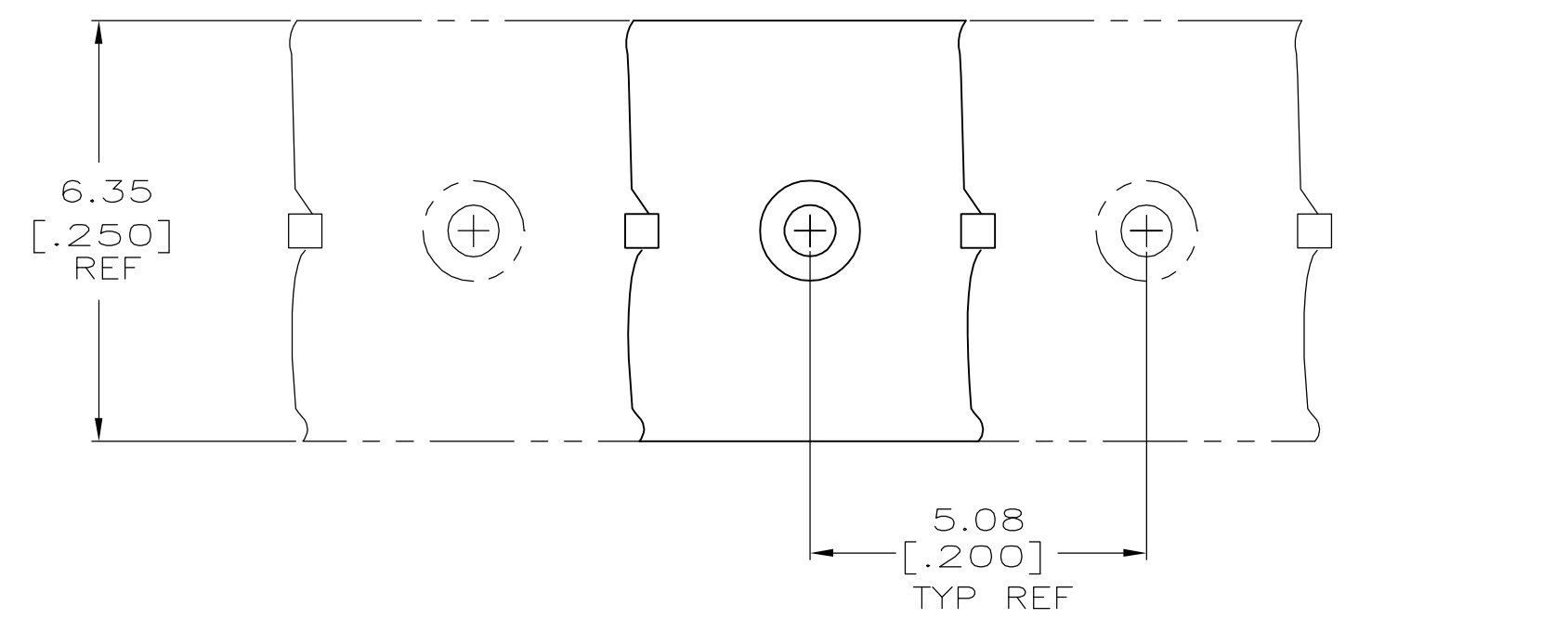

- 1 MATERIAL:  
EYELET- COPPER PER ASTM B 152  
SPRING- BERYLLIUM COPPER PER ASTM B 194.  
SEALANT- SILICONE RUBBER
- 2 TIN PER ASTM B 545, 0.00254 [.000100] MIN THICK.
- 3. PACKAGE 10,000 PER REEL.
- 4 TO ENSURE 1/2 OZ MIN RETENTION, DO NOT EXCEED 0.05 [.002] DIFFERENCE IN PIN DIA WHEN CHANGING TO A SMALLER DIA PIN.
- 5 PRODUCT IS OVALIZED FOR RETENTION IN THE P.C. BOARD. THE RECOMMENDED HOLE DIAMETER IS Ø1.80 [Ø.071] MINIMUM, +0.08 [.003] MAX. PRIOR TO SOLDERING.

Ø0.86-1.04 [.034-.041]	2	2	5645522-1
4 PIN DIAMETER	SPRING FINISH	EYELET FINISH	PART NUMBER

THIS DRAWING IS A CONTROLLED DOCUMENT.		DWN B. MCMASTER 15DEC05	Tyco Electronics Corporation Harrisburg, PA 17105-3608	
DIMENSIONS: mm [INCHES]		CHK J. HAVENER 15DEC05	APVD J. HAVENER 15DEC05	
TOLERANCES UNLESS OTHERWISE SPECIFIED:		NAME MINIATURE SPRING SOCKET ASSEMBLY, SERIES 4		
0 PLC ± -	1 PLC ± -	PRODUCT SPEC 108-14008		
2 PLC ± -	3 PLC ± 0.20 [.008]	APPLICATION SPEC 114-26004		
4 PLC ± -	ANGLES ± -	SIZE A2	CAGE CODE 00779	DRAWING NO G-5645522
MATERIAL 1	FINISH SEE TABLE	WEIGHT -	RESTRICTED TO -	
CUSTOMER DRAWING		SCALE 10:1	SHEET 1 of 1	REV 0

单击下面可查看定价，库存，交付和生命周期等信息

[>>TE Connectivity\(泰科\)](#)