

THIS DRAWING IS UNPUBLISHED. RELEASED FOR PUBLICATION  
 © COPYRIGHT - By - ALL RIGHTS RESERVED.

REVISIONS					
P	LTR	DESCRIPTION	DATE	DWN	APVD
F2		REVISED PER ECO-11-012152	15JUN11	HMR	DR
F3		REVISED PER ECO-17-008806	16FEB2018	RS	DR

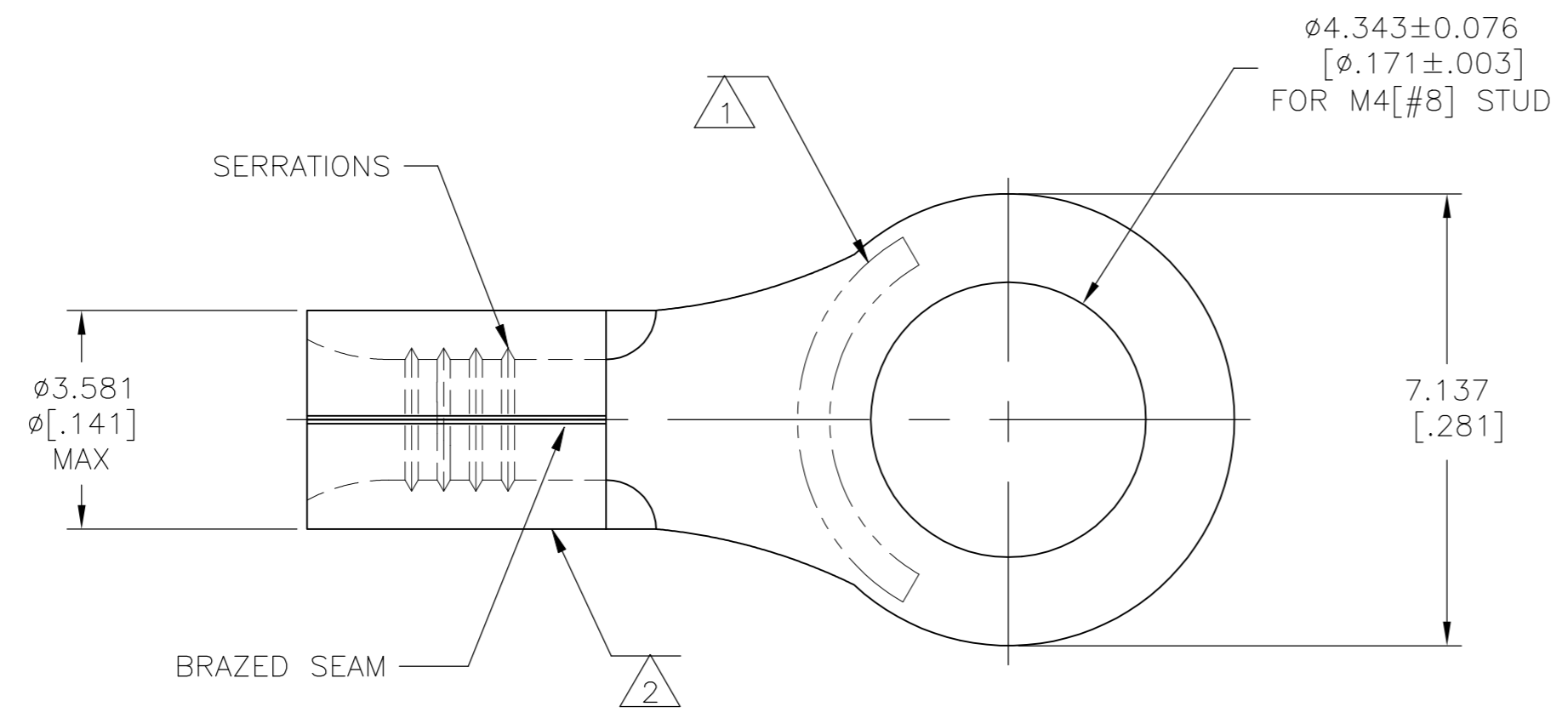

**AMP**  
 WIRE RANGE  
 22-16 AWG  
 SOLID OR STRANDED

- 1 STAMP AMP 22-18 APPROX AS SHOWN 22-16 TERMINALS ARE STAMPED 22-18 IN ACCORDANCE WITH MILITARY SPECIFICATION SAE AS7928 COMMERCIAL WIRE RANGE IS 22-16
- 2 WIRE BARREL COLOR CODED ORANGE TO DENOTE NICKEL MATERIAL
- 3 NOTE DELETED
- 4 NOTE DELETED
- 5 NOTE DELETED
- 6 NOTE DELETED

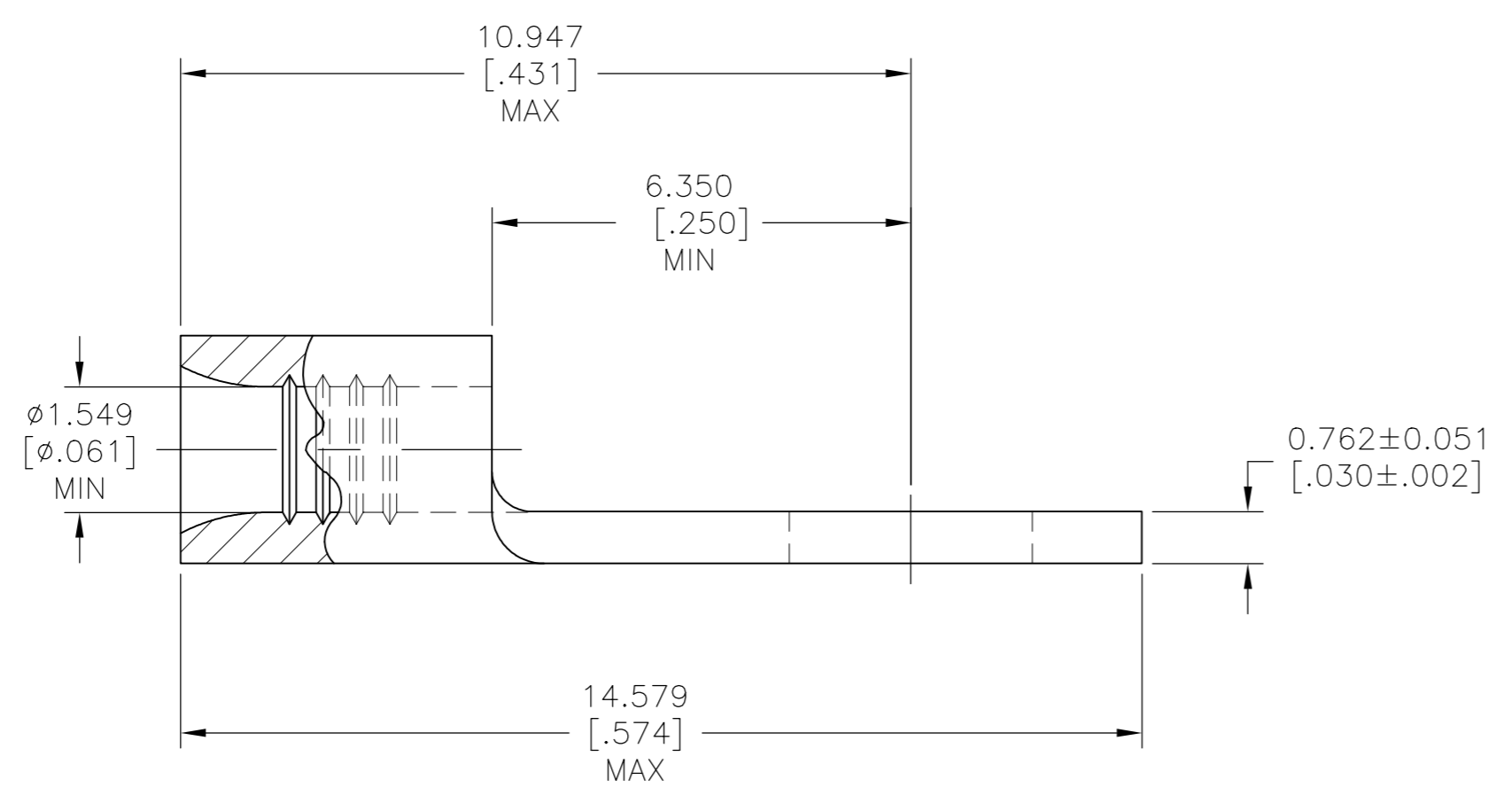

<b>AMP INCORPORATED</b>		MAX RECOMMENDED OPERATING TEMPERATURE: SEE TABLE
<b>CUSTOMER SERVICE SYSTEMS</b>		
FOR ADDITIONAL PRODUCT INFORMATION OR COPIES OF DRAWINGS AND TECHNICAL DOCUMENTS	PRODUCT INFORMATION CENTER 1-800-522-6752	VOLTAGE RATING: NOT APPLICABLE
FOR APPLICATION TOOLING INFORMATION	TOOLING ASSISTANCE CENTER 1-800-722-1111	WIRE CROSS SECTIONAL AREA RANGE: 0.26-1.65mm <sup>2</sup> [509-3,260] CIR MILS SOLID OR STRANDED
FOR ORDER ENTRY	1-800-526-5142	THIS DRAWING IS A CONTROLLED DOCUMENT FOR AMP INCORPORATED. IT IS SUBJECT TO CHANGE AND THE CONTROLLING ENGINEERING ORGANIZATION SHOULD BE CONTACTED FOR THE LATEST REVISION.

---	649°C [1200°F]	1000	LOOSE PIECE	321890
FINISH	MAX OPERATING TEMP	QTY	PACKAGING TYPE	PART NO

THIS DRAWING IS A CONTROLLED DOCUMENT.		DWN TA BRINKMAN 4-15-93	<b>STE</b> TE Connectivity Ltd.	
DIMENSIONS: mm [INCHES]		CHK DA PATTERSON 4-15-93		
TOLERANCES UNLESS OTHERWISE SPECIFIED: 0 PLC ± - 1 PLC ± - 2 PLC ± - 3 PLC ± 0.127[.005] 4 PLC ± - ANGLES ± -		APVD DE MILLER 4-15-93	NAME TERMINAL, RING TONGUE, HIGH TEMPERATURE, STRATO-THERM, 22-16 AWG	
MATERIAL NICKEL ASTM B-162 ANNEALED	FINISH SEE TABLE	APPLICATION SPEC	SIZE A2	CAGE CODE 00779
CUSTOMER DRAWING		WEIGHT -	DRAWING NO 321890	RESTRICTED TO -
		SCALE 10:1	SHEET 1 of 1	REV F3

单击下面可查看定价，库存，交付和生命周期等信息

[>>TE Connectivity\(泰科\)](#)