

N/C 1841-1-5620

REVISIONS			
SYM	DESCRIPTION	DATE	APPROVED
N/C	NEW RELEASE PER E.O. A12333	1-31-92	SP

PART NUMBER	SIZE	WIRE RANGE	SEALING RANGE		± A ±.010	± B ±.010	C MIN.	INSERT AND EXTRACT TCOL NUMBER	CRIMP TOOL
			MIN. O.D.	MAX. O.D.					
1841-1-5620	20	24-22-20	.040	.083	.101	.281	.163	M15570-20	M22520/1-01

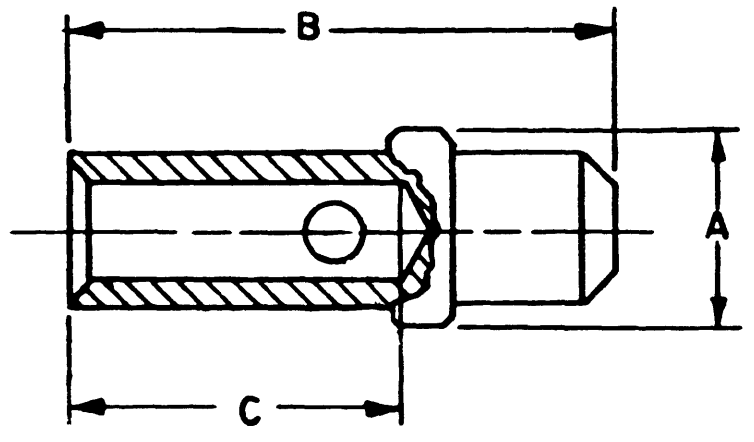

SIZE 20

SIZE	APPROX. WT. PER CONTACT IN LBS.
20	.0004

3. CONTACT FINISH: DEUTSCH ALLOY OVER NICKEL PER QQ-N-290.
2. BODY MATERIAL: PER MIL-C-39029 TYPE A.
1. DIMENSIONS ARE IN INCHES UNLESS OTHERWISE SPECIFIED.

NOTE:

SIGNATURE & DATE	
DR	B. WOOD 1-24-92
CHK	Jo Powell 1-31-92
PE	B. WOOD 1-24-92
APPD	
SCALE	ONE WT

CONTACT
TERMINAL JUNCTION
SIZE 20

ENVELOPE

CP	MATL. CODE
The Deutsch Company ELECTRONIC COMPONENTS DIVISION Municipal Airport Banning, California	
B	1841-1-5620
DWG SIZE	CODE 11139 SHEET 1 OF 1

单击下面可查看定价，库存，交付和生命周期等信息

[>>TE Connectivity\(泰科\)](#)