

4

3

2

1

THIS DRAWING IS UNPUBLISHED. RELEASED FOR PUBLICATION  
 © COPYRIGHT - TE Connectivity ALL RIGHTS RESERVED.

REVISIONS					
P	LTR	DESCRIPTION	DATE	DWN	APVD
	J	REVISED PER ECN 0G10-0114-98	10AUG98	SU	MB
	J1	REVISED PER ECO-17-014438	10OCT2017	RS	DR
	J2	REVISED PER ECO-18-003950	15MAR2018	RS	DR

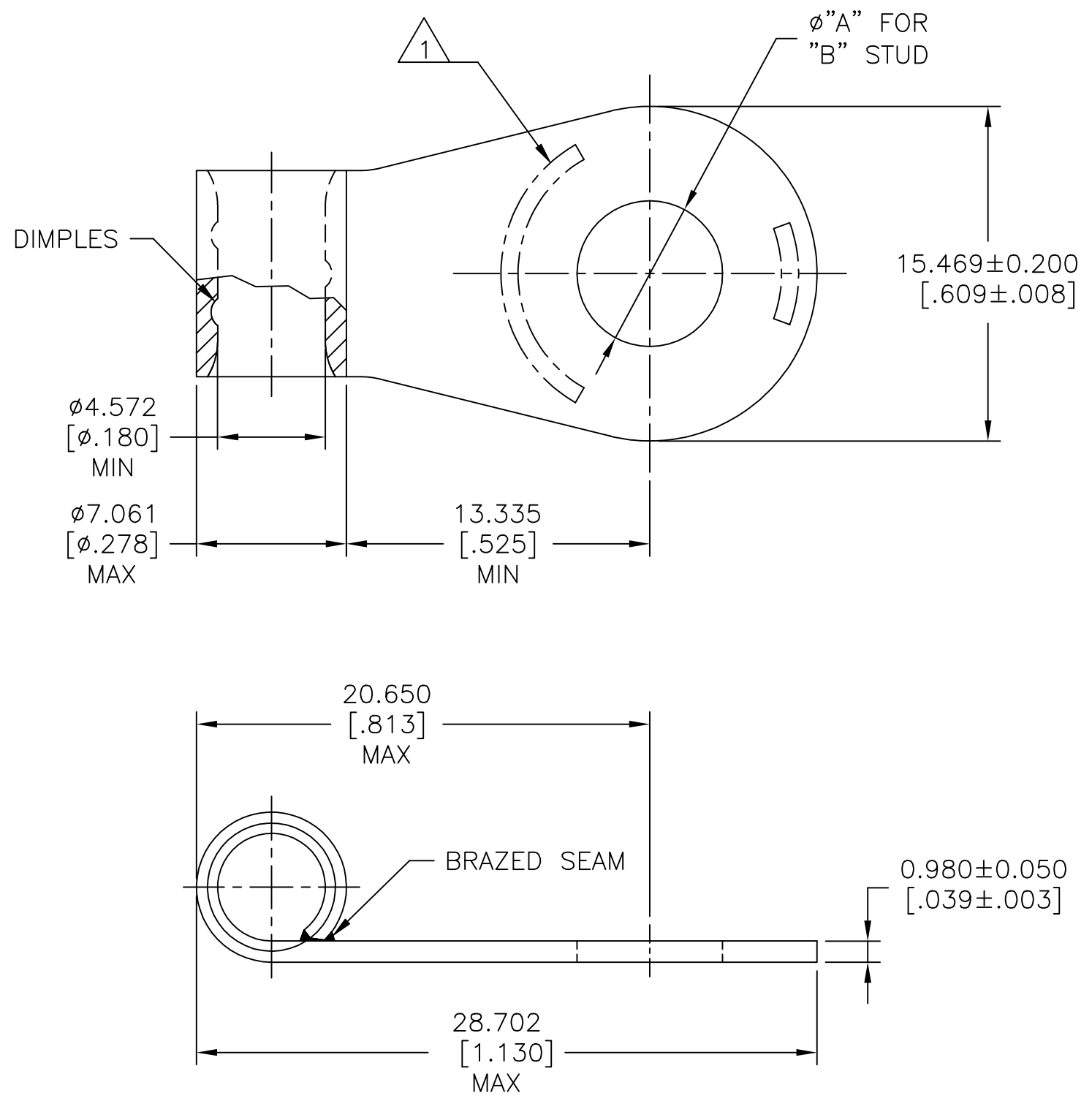

<b>AMP</b> WIRE RANGE	E13288 Listed
8 AWG SOLID OR STRANDED	8 AWG STRANDED
LR7189 Certified	MILITARY P/N AND CLASS
8 AWG SOLID OR STRANDED	NOT APPLICABLE

- 1 STAMP AMP 8W\* APPROX AS SHOWN.
- 2 TIN PLATE 0.00254[.000100] MIN EXT THICK PER ASTM B545.
- 3 NOTE DELETED.
- 4 NOTE DELETED.

M8 <sup>5/16</sup>	8.331 [.328]	100	LOOSE PIECE	2	322727-2
M6 <sup>1/4</sup>	6.731 [.265]	100	LOOSE PIECE	2	322727
"B"	"A"	QTY.	PACKAGE TYPE	FINISH	PART NUMBER

**AMP INCORPORATED**  
**CUSTOMER SERVICE SYSTEMS**

FOR ADDITIONAL PRODUCT INFORMATION OR COPIES OF DRAWINGS AND TECHNICAL DOCUMENTS  
 PRODUCT INFORMATION CENTER  
 1-800-522-6752

FOR APPLICATION TOOLING INFORMATION  
 TOOLING ASSISTANCE CENTER  
 1-800-722-1111

FOR ORDER ENTRY  
 1-800-526-5142

RECOMMENDED OPERATING TEMPERATURE:  
 170°C[338°F]MAX

VOLTAGE RATING:  
 NOT APPLICABLE

WIRE CROSS SECTIONAL AREA RANGE:  
 6.64-10.54mm<sup>2</sup>[13,100-20,800] CIR MILS  
 SOLID OR STRANDED

THIS DRAWING IS A CONTROLLED DOCUMENT.

DIMENSIONS:  
 mm [INCHES]

TOLERANCES UNLESS OTHERWISE SPECIFIED:

0 PLC ± -  
 1 PLC ± -  
 2 PLC ± -  
 3 PLC ± 0.127[.005]  
 4 PLC ± -  
 ANGLES ± -

MATERIAL  
 COPPER  
 PER ASTM B-152  
 ANNEALED

FINISH  
 SEE NOTES

DWN DK SCHRUM 11JUN97  
 CHK MJ SPICER 12JUN97  
 APVD JL MECKLEY 12JUN97

**TE** TE Connectivity Ltd.

NAME  
 TERMINAL, RING TONGUE,  
 FLAG, SOLISTRAND™  
 8 AWG

SIZE A3 CAGE CODE 00779 DRAWING NO C=322727 RESTRICTED TO -

WEIGHT CUSTOMER DRAWING SCALE 4:1 SHEET 1 of 1 REV J2

单击下面可查看定价，库存，交付和生命周期等信息

[>>TE Connectivity\(泰科\)](#)