

4

3

2

1

THIS DRAWING IS UNPUBLISHED. RELEASED FOR PUBLICATION  
COPYRIGHT BY TYCO ELECTRONICS CORPORATION, ALL RIGHTS RESERVED.

LOC	DIST	REVISIONS					
		P	LTR	DESCRIPTION	DATE	DWN	APVD
DS	-		C1	REVISED (ECR-11-005815)	22.MAR.'11	KT	HG

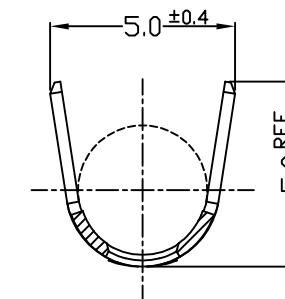
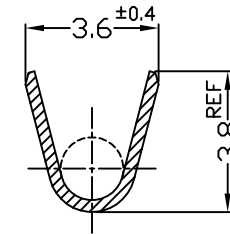
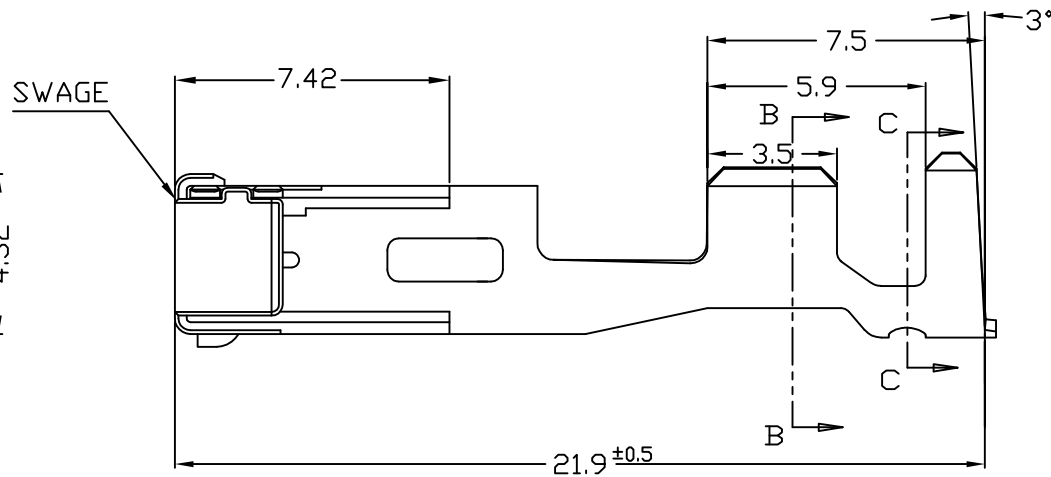
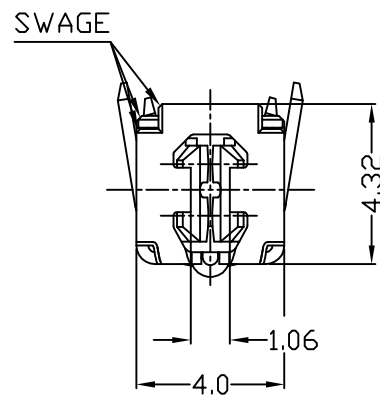
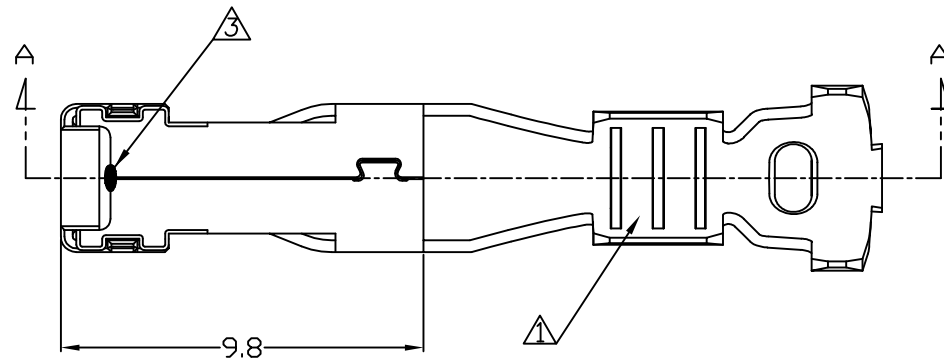

SECTION "B-B"

SECTION "C-C"

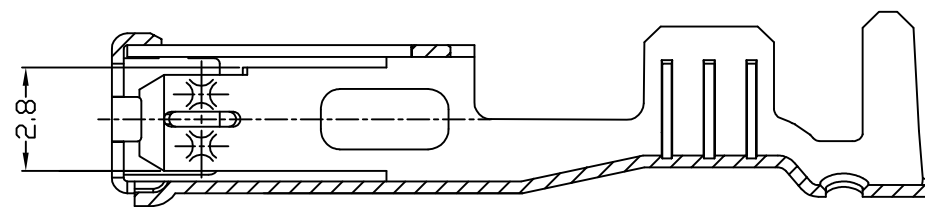
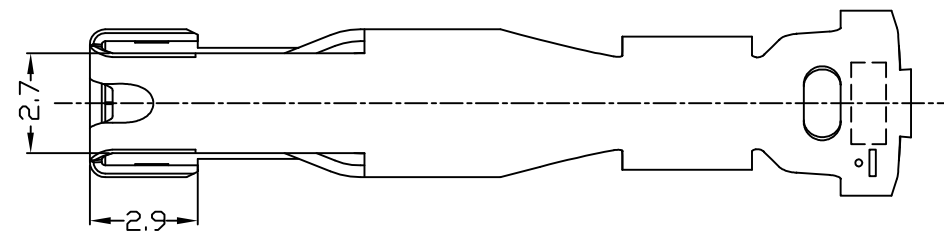

SECTION "A-A"

NOTE;

- ▲ THREE SERRATIONS CENTERED IN WIRE BARREL.
- 2 WIRE SIZE EQUIV 1.0 ~ 2.0SQ.
- APPLICATION SPEC: 114-61033
- △ WELDING POINT

THIS DRAWING IS A CONTROLLED DOCUMENT FOR TYCO ELECTRONICS CORPORATION  
IT IS SUBJECT TO CHANGE AND THE CONTROLLING ENGINEERING ORGANIZATION  
SHOULD BE CONTACTED FOR THE LATEST REVISION.

DIMENSIONS: MM	TOLERANCES UNLESS OTHERWISE SPECIFIED: 0 <XX<10 ± 0.25 10<XX<30 ± 0.3 ANGLES ± 3°
MATERIAL SEE TABLE	FINISH SEE TABLE

PRE-TINNED	CuNiSi Alloy 0.32THK.	936606-1			
FINISH	MATERIAL	PART NO			
DWN KT JUNG	 TE Connectivity	NAME 2.8mm MCP-E SEALED RECEP CONTACT			
CHK KT LIM					
APVD HG CHD					
PRODUCT SPEC -					
APPLICATION SPEC 114-61033	SIZE	CAGE CODE	DRAWING NO	RESTRICTED TO	
WEIGHT -	A3	00779	C-936606	-	
CUSTOMER DRAWING			SCALE 5/1	SHEET 1 OF 1	REV C1

单击下面可查看定价，库存，交付和生命周期等信息

[>>TE Connectivity\(泰科\)](#)