

THIS DRAWING IS UNPUBLISHED. RELEASED FOR PUBLICATION
 © COPYRIGHT BY TYCO ELECTRONICS CORPORATION. ALL RIGHTS RESERVED.

LOC	DIST	REVISIONS					
AD	00	P	LTR	DESCRIPTION	DATE	DWN	APVD
		K		ECO-05-004683	17JAN06	BSV	MM

NOTE:
FINISH

- △1 .000030 GOLD OVER NICKEL SELECTIVE ON CONTACT AREA.
- △2 .000015 GOLD OVER .000050 NICKEL SELECTIVE ON CONTACT AREA.
- △3 GOLD FLASH OR TIN PLATE OVER NICKEL ON SOLDER TAB.
- △4 GOLD PLATING THICKNESS TO BE MEASURED WITH A MASK HAVING A .012 APERTURE LOCATED .156 FROM THE NOSE OF CONTACT
- △5 .000100/.000200 BRIGHT TIN LEAD PLATING ALL OVER, NICKEL UNDER PLATE ALL OVER.
- △6 GOLD FLASH OR MATTE TIN PLATE OVER NICKEL ON SOLDER TAB.

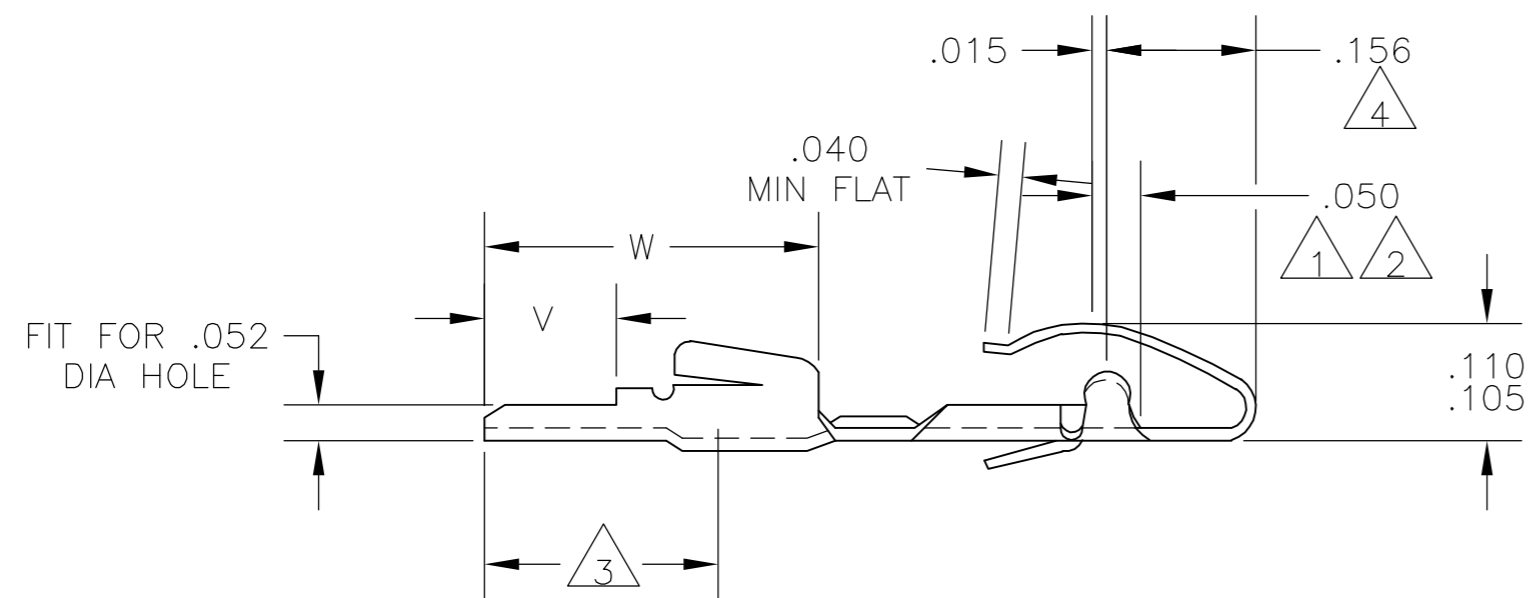
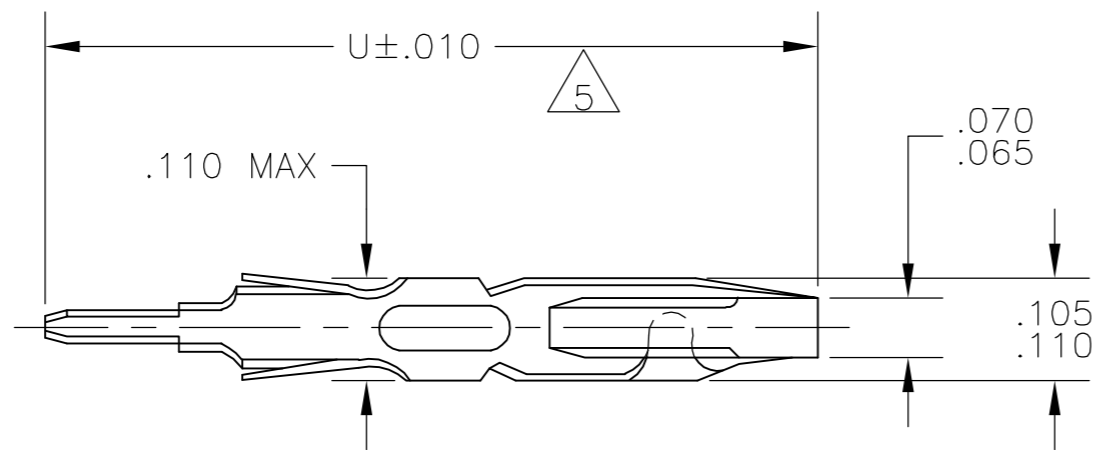

	1/16	△2 △6	.345	.120	.810	5-583294-2
	1/16	△1 △6	.345	.120	.810	5-583294-1
OBSOLETE	1/16	△5	.345	.120	.810	583294-8
OBSOLETE	3/32	△2	.375	.150	.840	583294-4
OBSOLETE	3/32	△1	.375	.150	.840	583294-3
	1/16	△2 △1	.345	.120	.810	583294-2
	1/16	△1	.345	.120	.810	583294-1
	BOARD THK	FINISH	W	V	U	PART NO.

THIS DRAWING IS A CONTROLLED DOCUMENT.		DWN	26SEP67	Tyco Electronics Corporation Harrisburg, PA 17105-3608
DIMENSIONS: INCHES		CHK	14SEP67	
TOLERANCES UNLESS OTHERWISE SPECIFIED:		APVD	18SEP67	
0 PLC ± - 1 PLC ± - 2 PLC ± - 3 PLC ± - 4 PLC ± - ANGLES ± -		NAME		AMP LEAF SOLDER DIP CONTACT FOR .052 DIA.HOLE
MATERIAL PHOSPHOR BRONZE		FINISH SEE TABLE		
		PRODUCT SPEC	SIZE	
		APPLICATION SPEC	CAGE CODE	
		WEIGHT	DRAWING NO	
		CUSTOMER DRAWING	RESTRICTED TO	
		SCALE	A2 00779 C=583294	
		SHEET	1 OF 1	
		REV	K	

583294

单击下面可查看定价，库存，交付和生命周期等信息

[>>TE Connectivity\(泰科\)](#)