

REVISIONS					
P	LTR	DESCRIPTION	DATE	DWN	APVD
F4		RELEASE PER ECR-15-009002	31JAN2019	JH	PKS

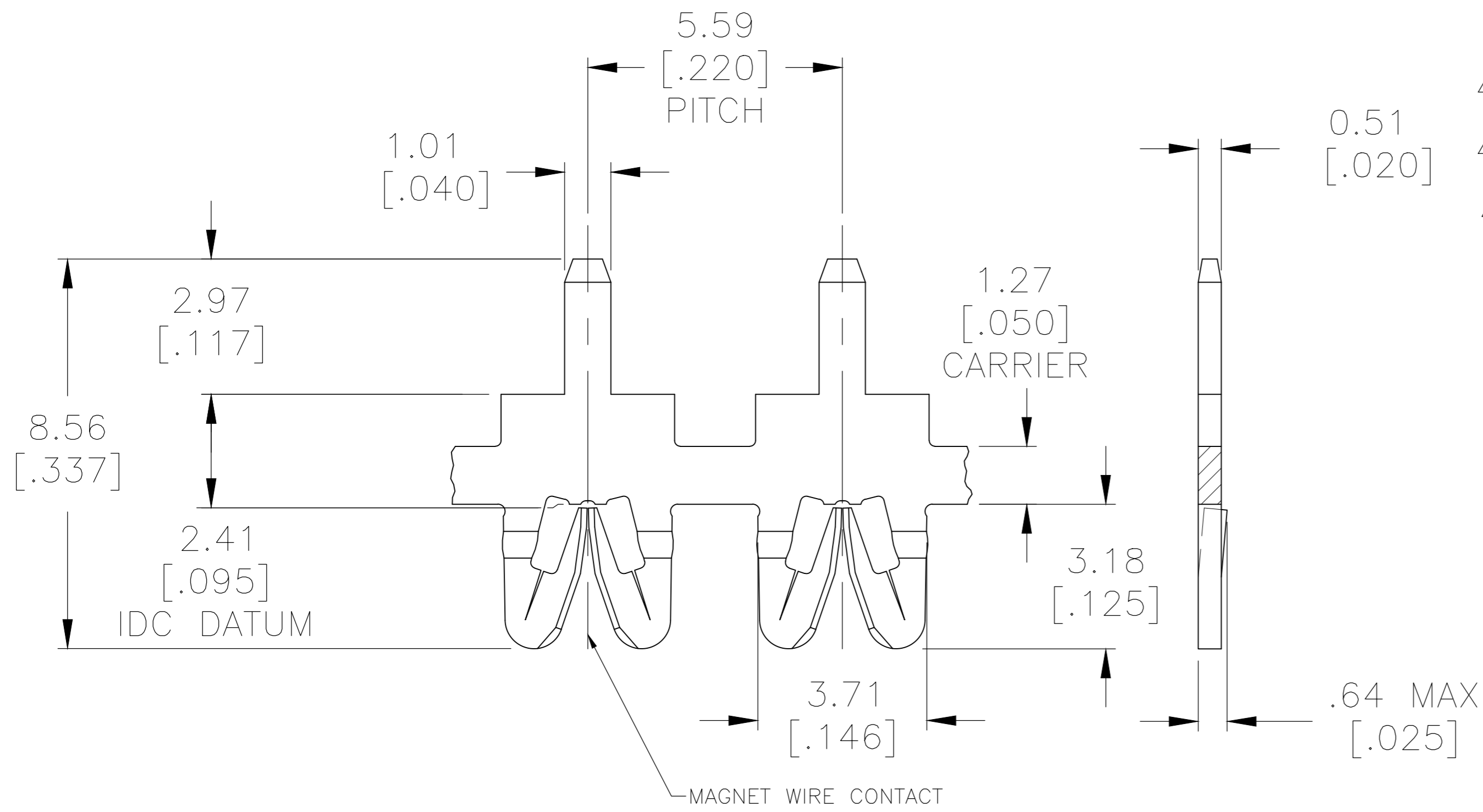

- 1 SPECIFICATIONS:  
MAGNET WIRE #18 - #34 AWG,  
1.02MM(.040")-0.16MM(.006") DIA COPPER.
- 2 POCKET RECOMMENDATION: #1601424
- 3 TERMINAL APPLICATION TO COMPLY WITH TYCO  
ELECTRONICS SPECIFICATION 114-13166 FIGURE 5
- 4 POST TIN PLATE .000120-.000200 THK  
OVER .000050 MIN THK NICKEL
- 5 OBSOLETE PARTS: OBSOLETE CIS STREAMLINING PER D.RENAUD/D.SINISI

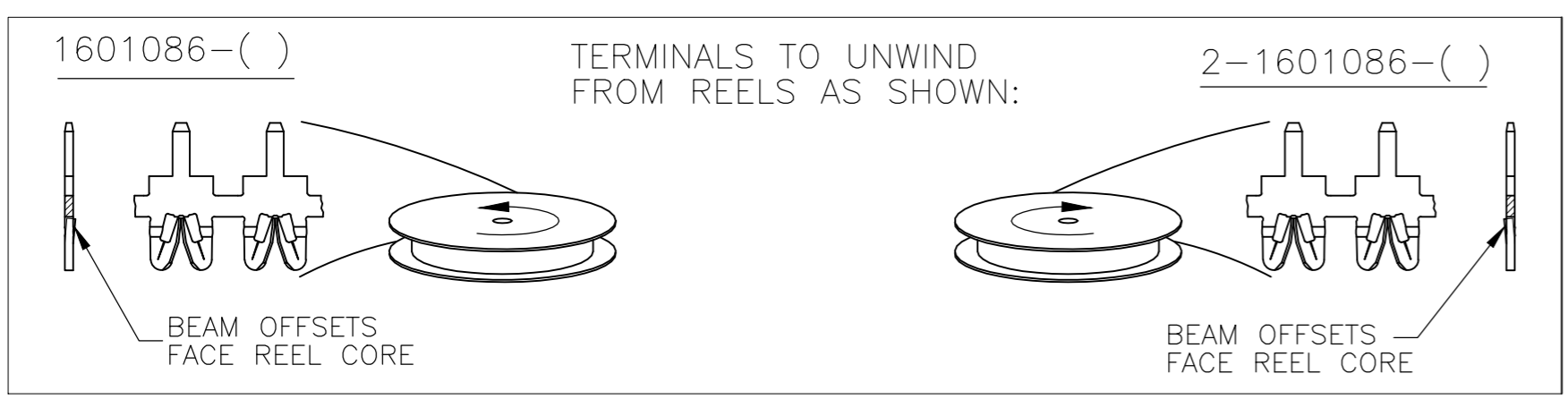
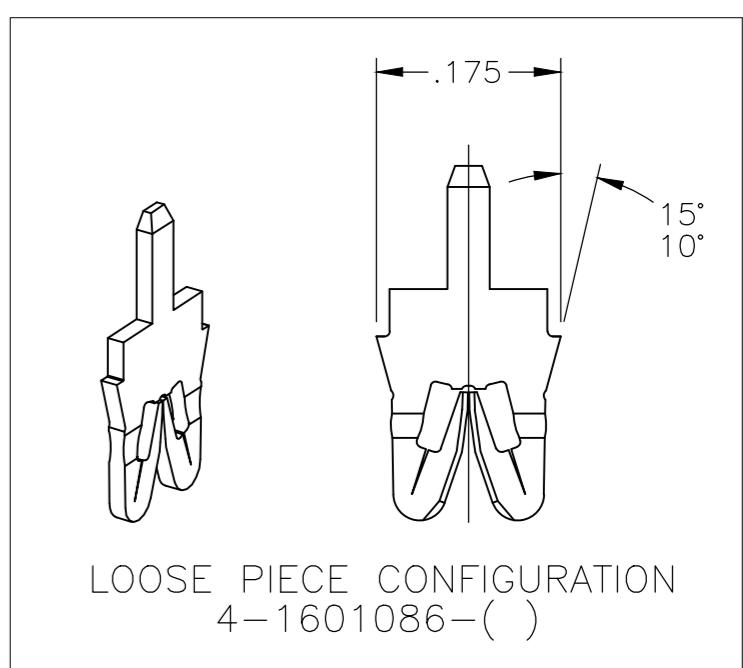

	TIN OVER NICKEL 4	-	4-1601086-3
OBSOLETE	TIN OVER NICKEL 4	-	1601086-3
OBSOLETE	Unplated	131-158-000	2-1601086-1
SUPERSEDED BY 1601086-3	Post Tin Lead Plate over Copper Underplate	131-157-024	1601086-2
OBSOLETE	Unplated	131-157-000	1601086-1
	FINISH	REFERENCE PART NUMBER	PART NUMBER

THIS DRAWING IS A CONTROLLED DOCUMENT.

DIMENSIONS: mm [INCHES]	TOLERANCES UNLESS OTHERWISE SPECIFIED: 0 PLC ± - 1 PLC ± 0.25 [.010] 2 PLC ± 0.13 [.005] 3 PLC ± - 4 PLC ± - ANGLES ± 2°	DWN J.WELLER 11JAN2002 CHK M.FEHER 11JAN2002 APVD K.RANDOLPH 11JAN2002 PRODUCT SPEC 108-2085 APPLICATION SPEC 3	NAME STANDARD RANGE WIRE TO .117 P.C. BOARD SIAMEZE TERMINAL
MATERIAL BRASS, SPRING HARD	FINISH SEE TABLE	WEIGHT 0.000000	SIZE A2 CAGE CODE 00779 DRAWING NO. C=1601086 RESTRICTED TO -
CUSTOMER DRAWING		SCALE 11:1	SHEET 1 OF 1 REV F4

单击下面可查看定价，库存，交付和生命周期等信息

[>>TE Connectivity\(泰科\)](#)