

THIS DRAWING IS UNPUBLISHED. RELEASED FOR PUBLICATION, 19 .
© COPYRIGHT 19 BY AMP INCORPORATED, HARRISBURG, PA. ALL INTERNATIONAL RIGHTS RESERVED. AMP PRODUCTS MAY BE COVERED BY U.S. AND FOREIGN PATENTS AND/OR PATENTS PENDING.

| REVISIONS | | | | | | |
|-----------|---|------|-----|------------------------|----------|----------|
| P | F | ZONE | LTR | DESCRIPTION | DATE | APPROVED |
| 0 | ✓ | | D | REL. WAS 5210-659-1 | | |
| ✓ | ✓ | A | | REV LOC & DIST AD-4171 | 11-22-89 | BF |

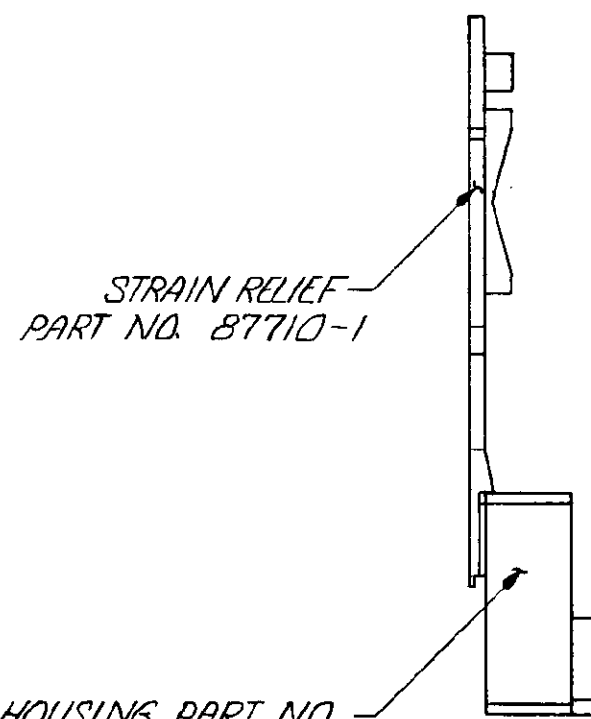
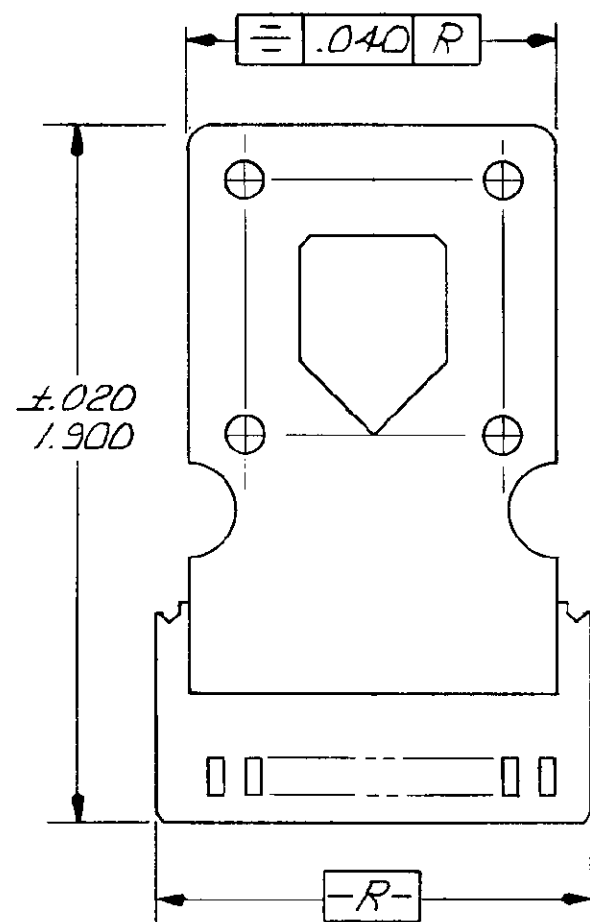

1. STRAIN RELIEF ULTRASONICALLY WELDED TO THE HOUSING.

103583

| | | |
|------------------|-------------|----------|
| | | |
| 102387-4 | 20 | 103583-1 |
| HOUSING PART NO. | NO. OF POS. | PART NO. |

| | | | |
|--------------------------------------------------------------------------------------------------------------|----------------------------------|------------------------------------------------------------------------------------------------------------|-------------------------|
| UNLESS OTHERWISE SPECIFIED DIMENSIONS ARE IN INCHES. TOLERANCES ON: DECIMALS \pm = ANGLES \pm = | CONTRACT NO | AMP AMP INCORPORATED Harrisburg, Pa. 17105 | |
| | DR <i>MA Meyer 1-30-85</i> | | |
| MATERIAL FLAME RETARDANT THERMOPLASTIC COLOR: BLACK | CHK <i>W. J. ... 1/21/85</i> | NAME <i>ASSEMBLY, MOD IV, CRIMP SNAP- IN HOUSING WITH STRAIN RELIEF, DOUBLE ROW, .100 X .100 Q</i> | |
| | APPD <i>W. J. ... 1/31/85</i> | SIZE C | FSCM NO 00779 |
| FINISH | DSGN APPD | DRAWING NO 103583 | |
| | OTHER APPD | SCALE <i>4:1</i> | SHEET |

单击下面可查看定价，库存，交付和生命周期等信息

[>>TE Connectivity\(泰科\)](#)