

4

3

2

1

THIS DRAWING IS UNPUBLISHED.

RELEASED FOR PUBLICATION

© COPYRIGHT - TE Connectivity Ltd.

ALL RIGHTS RESERVED.

REVISIONS

P	LTR	DESCRIPTION	DATE	DWN	APVD
	E1	REVISED PER ECR-16-001552	20DEC2019	RZ	RS

- ① BRASS PER QQ-B-626
- ② GOLD PLATE PER MIL-G-45204
0.76µm [.000030] MINIMUM THICK
- ③ GOLD PLATE PER MIL-G-45204
1.27µm [.000050] MINIMUM THICK
- ④ GOLD PLATE PER MIL-G-45204
2.54µm [.000100] MINIMUM THICK
- ⑤ SILVER PLATE PER QQ-S-365
2.54µm [.000100] MINIMUM THICK
- ⑥ GOLD PLATE PER MIL-G-45204
0.20µm [.000008] MINIMUM THICK

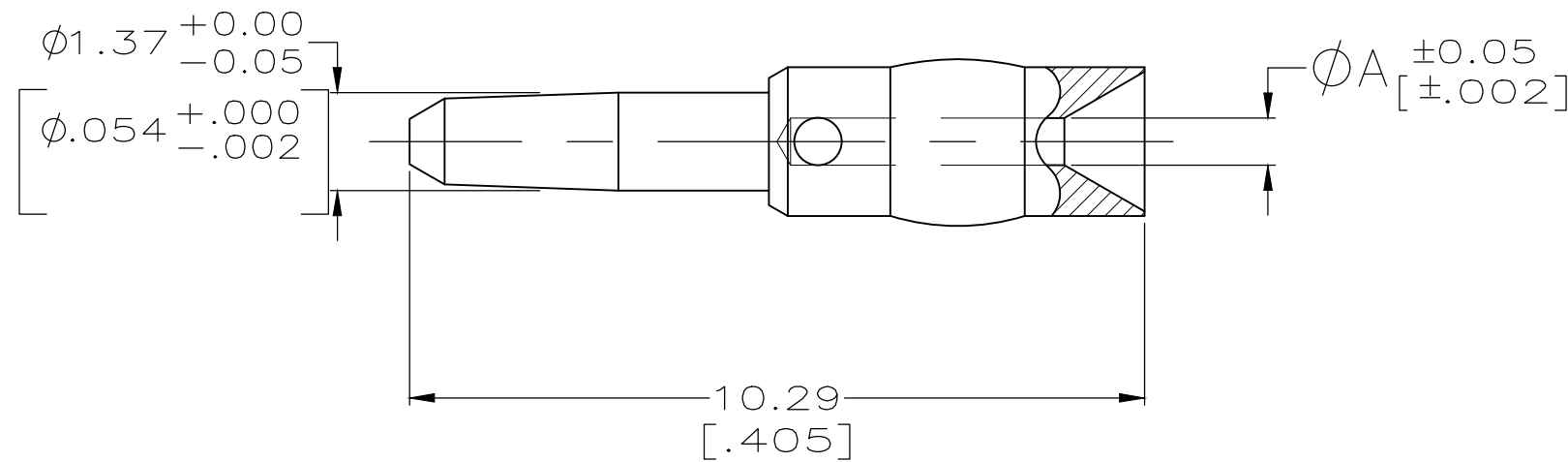

1.09 [.043]	④	1-331357-7
0.99 [.039]	④	1-331357-6
0.99 [.039]	⑤	1-331357-5
1.09 [.043]	⑥	1-331357-4
0.99 [.039]	⑥	1-331357-3
1.09 [.043]	③	1-331357-2
0.99 [.039]	③	1-331357-0

A	FINISH	PART NUMBER
---	--------	-------------

THIS DRAWING IS A CONTROLLED DOCUMENT.		DWN B.SCOTT 2-15-91															
DIMENSIONS: INCHES		CHK J. LIPPERT 3-20-91															
TOLERANCES UNLESS OTHERWISE SPECIFIED:		APVD -	NAME CONTACT, PLUG, SERIES BNC														
<table border="1"> <tr><td>0 PLC</td><td>± -</td></tr> <tr><td>1 PLC</td><td>± -</td></tr> <tr><td>2 PLC</td><td>± 0.13 [.005]</td></tr> <tr><td>3 PLC</td><td>± -</td></tr> <tr><td>4 PLC</td><td>± -</td></tr> <tr><td>ANGLES</td><td>± -</td></tr> </table>		0 PLC	± -	1 PLC	± -	2 PLC	± 0.13 [.005]	3 PLC	± -	4 PLC	± -	ANGLES	± -	PRODUCT SPEC -	RESTRICTED TO -		
0 PLC	± -																
1 PLC	± -																
2 PLC	± 0.13 [.005]																
3 PLC	± -																
4 PLC	± -																
ANGLES	± -																
MATERIAL 1		APPLICATION SPEC -	SIZE A3	CAGE CODE 00779	DRAWING NO C-331357												
FINISH SEE TABLE		WEIGHT 0.000000	SCALE 10:1														
CUSTOMER DRAWING			SHEET 1 OF 1		REV E1												

单击下面可查看定价，库存，交付和生命周期等信息

[>>TE Connectivity\(泰科\)](#)