

THIS DRAWING IS UNPUBLISHED. RELEASED FOR PUBLICATION 20
 © COPYRIGHT 20 BY - ALL RIGHTS RESERVED.

REVISIONS				
P	LTR	DESCRIPTION	DATE	APVD
	A	INITIAL RELEASE	30APR2021	AJ SZ

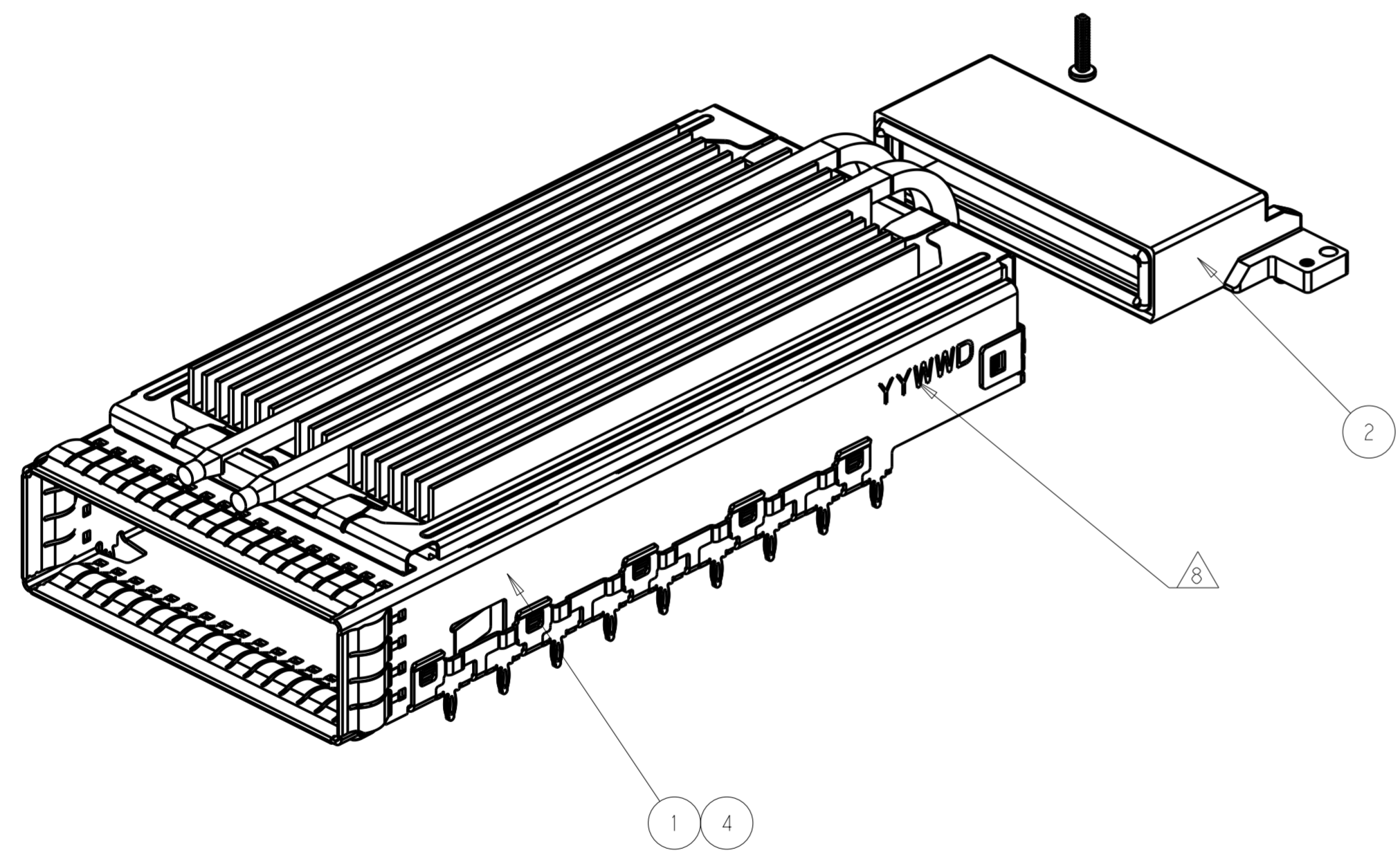

- 1. MATERIAL :CAGE :0.4MM THICK NICKEL SILVER ALLOY;
EMI SPRING: COPPER ALLOY;
HEAT SINK CLIP: STAINLESS STEEL;
HEAT SINK:ALUMINUM ALLOY;
RECEPTACLE COVER:ZINC ALLOY;
- 2. FINISH: EMI SPRING :1.27um NICKEL PALTING OVER ALL;
HEAT SINK:BLACK ANODIZED COATING;
RECEPTACLE COVER: 1.27um MIN NICKEL PLATING OVER COPPER PLATING;
HEAT SINK CLIP:PASSIVATE;
- 3.MATES WITH CFP MSA COMPLIANT TRANSCEIVERS.
- 4.DATUM AND BASIC DIMENSION ESTABLISHED BY CUSTOMER.
- 5.MINIMUM PC BOARD THICKNESS: SIGLE SIDE APPLICATIONS=2.99±0.63mm.
BELLY TO BELLY APPLICATION=3.0mm MIN.
- 6.PADS AND VIAS CHASSIS GROUND;
- 7:REFERENCE APPLICATION SOEC 114-32146,HOLE A, FOR
RECOMMENDED DRILL HOLE DIAMETER AND PLATING THICKNESS.
- 8:DATE CODE LOCATED AT APPROXIMATE AREA AS SHOWN

QTY	UNIT	PAR NUMBER	DESCRIPTION	ITEM
2	2	2292789-1	SCREW	3
1	1	2274846-1	RECEPTACLE COVER ASSEMBLY	2
1	-	2314914-2	CAGE ASSEMBLY WITH H/S,LP,CFP2 1X1	4
-	1	2314914-1	CAGE ASSEMBLY WITH H/S,LP,CFP2 1X1	1
-2	-1	PAR NUMBER	DESCRIPTION	ITEM

THIS DRAWING IS A CONTROLLED DOCUMENT.		DWN ANDY XIE 28DEC2016	STE TE Connectivity	
		CHK SEAN HAN 28DEC2016		
		APVD SEAN HAN 28DEC2016	NAME HARD WARE KITS WIHT LP CFP2 1X1	
DIMENSIONS: mm		PRODUCT SPEC 108-32103	SIZE A2	
TOLERANCES UNLESS OTHERWISE SPECIFIED: 0 PLC ± 1 PLC ±0.25 2 PLC ±0.15 3 PLC ±0.10 4 PLC ±0.05 ANGLES ± FINISH		APPLICATION SPEC 114-32145	DRAWING NO C-2314979	
MATERIAL -		WEIGHT -	RESTRICTED TO -	
		CUSTOMER DRAWING	SCALE 1:1	SHEET 1 OF 7
			REV A	

THIS DRAWING IS UNPUBLISHED. RELEASED FOR PUBLICATION 20
 © COPYRIGHT 20 BY - ALL RIGHTS RESERVED.

REVISIONS					
P	LTR	DESCRIPTION	DATE	DWN	APVD
-		SEE SHEET 1	-	-	-

2314914-1 AS SHOWN IN THIS SHEET:

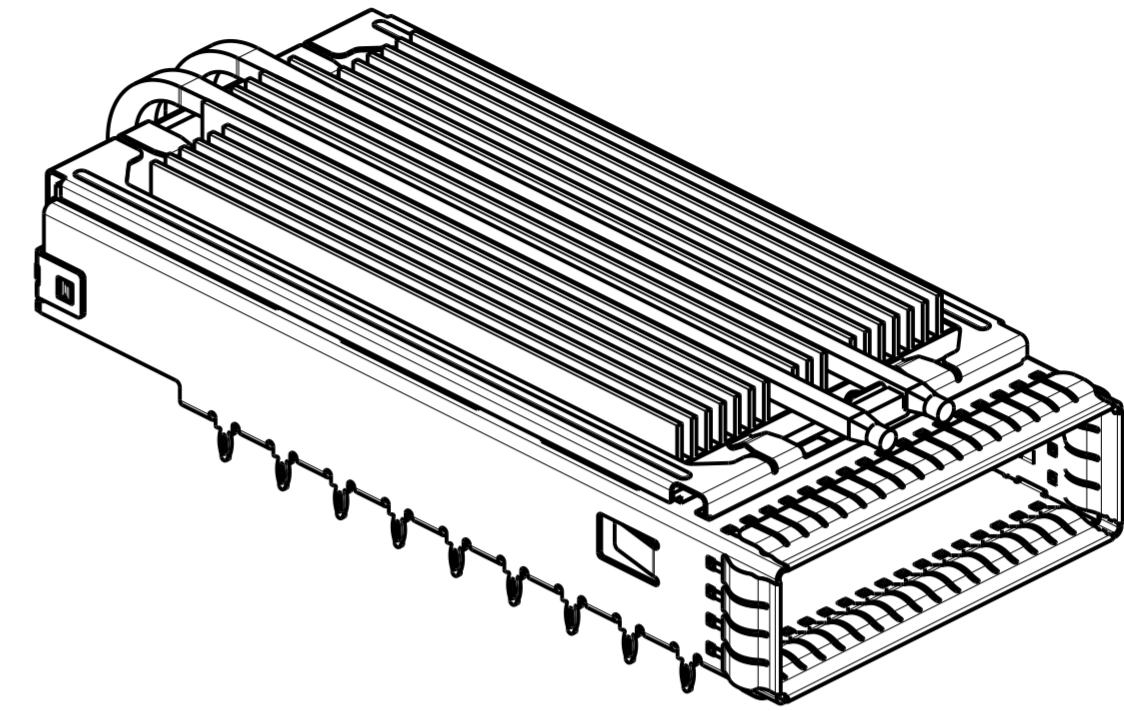
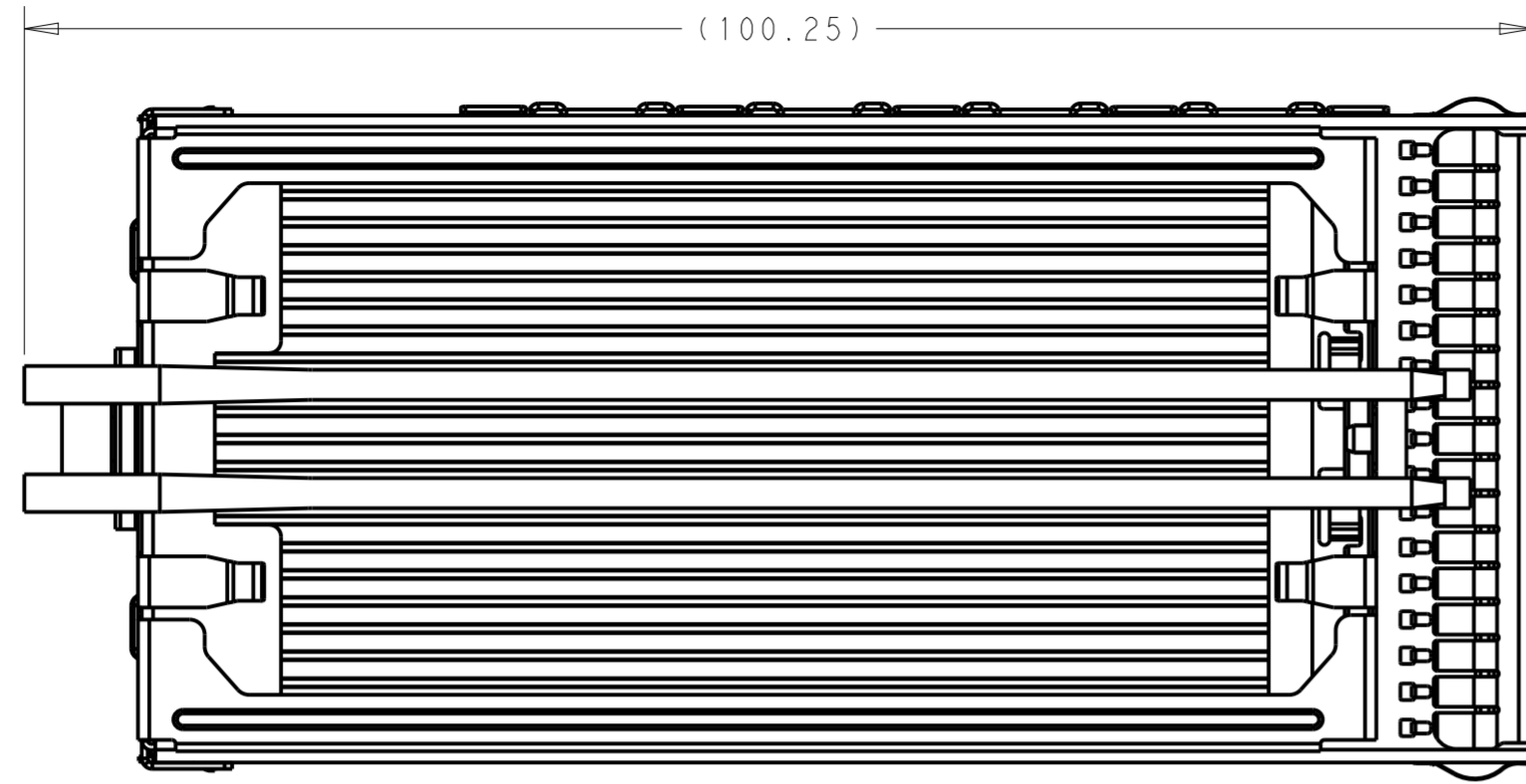

2314914-1 AS SHOWN
SCALE 3:2

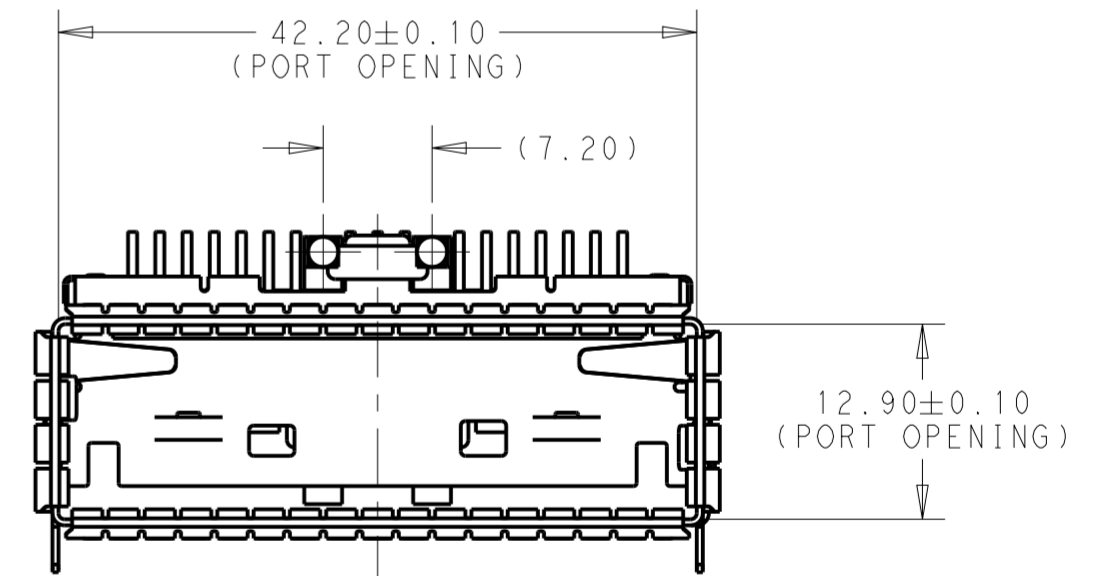
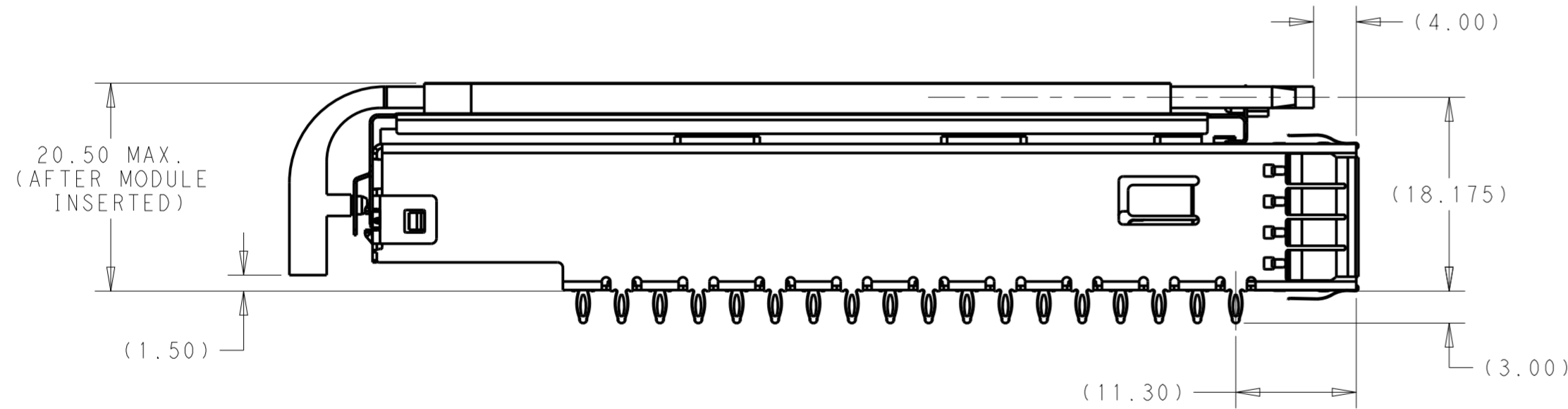

THIS DRAWING IS A CONTROLLED DOCUMENT.		DWN ANDY.XIF 28DEC2016	TE Connectivity	
DIMENSIONS:		CHK SEAN.HAN 28DEC2016		
mm		APVD SEAN.HAN 28DEC2016		
		PRODUCT SPEC 108-32103		
TOLERANCES UNLESS OTHERWISE SPECIFIED:		APPLICATION SPEC 114-32145	NAME HARD WARE KITS WIHT LP CFP2 1X1	RESTRICTED TO
0 PLC ± 1 PLC ±0.25 2 PLC ±0.15 3 PLC ±0.1 4 PLC ±0.05 ANGLES ±1 FINISH		WEIGHT -	SIZE A2	CAGE CODE -
MATERIAL SEE NOTES		CUSTOMER DRAWING	DRAWING NO G-2314979	SCALE 1:1
SEE NOTES			SHEET 2 OF 7	REV A

THIS DRAWING IS UNPUBLISHED. RELEASED FOR PUBLICATION 20
 © COPYRIGHT 20 BY - ALL RIGHTS RESERVED.

REVISIONS				
P	LTR	DESCRIPTION	DATE	APVD
-		SEE SHEET 1	-	-

2314914-2 AS SHOWN IN THIS SHEET:

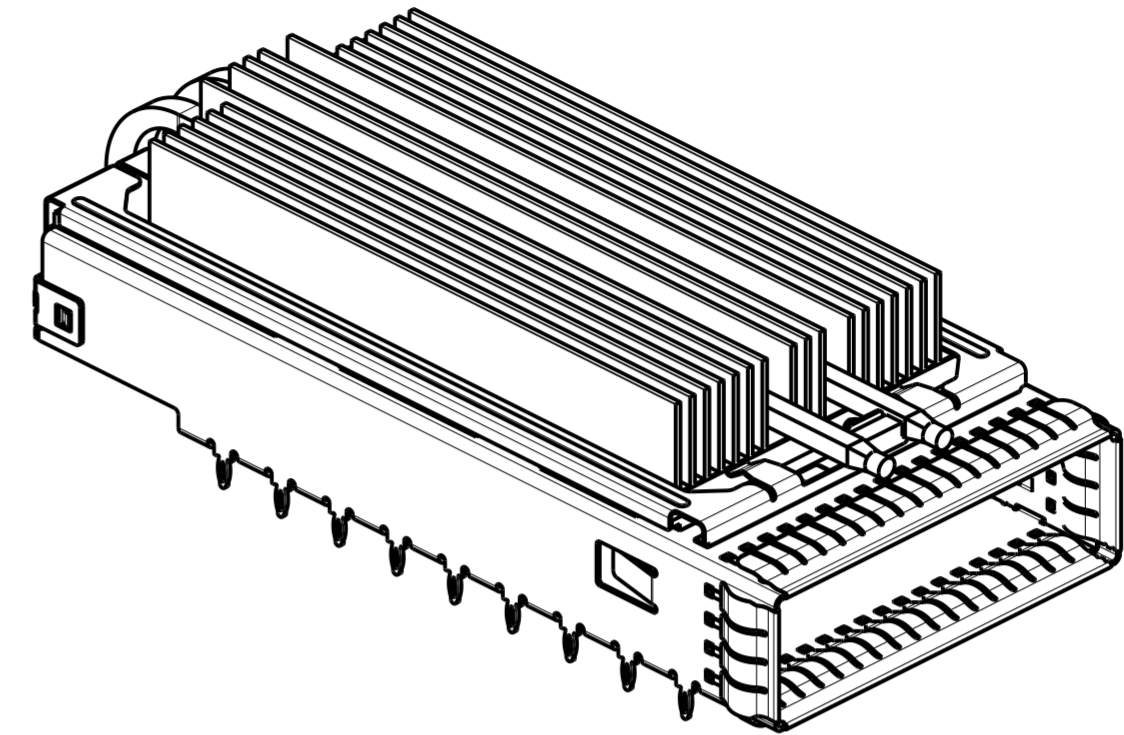
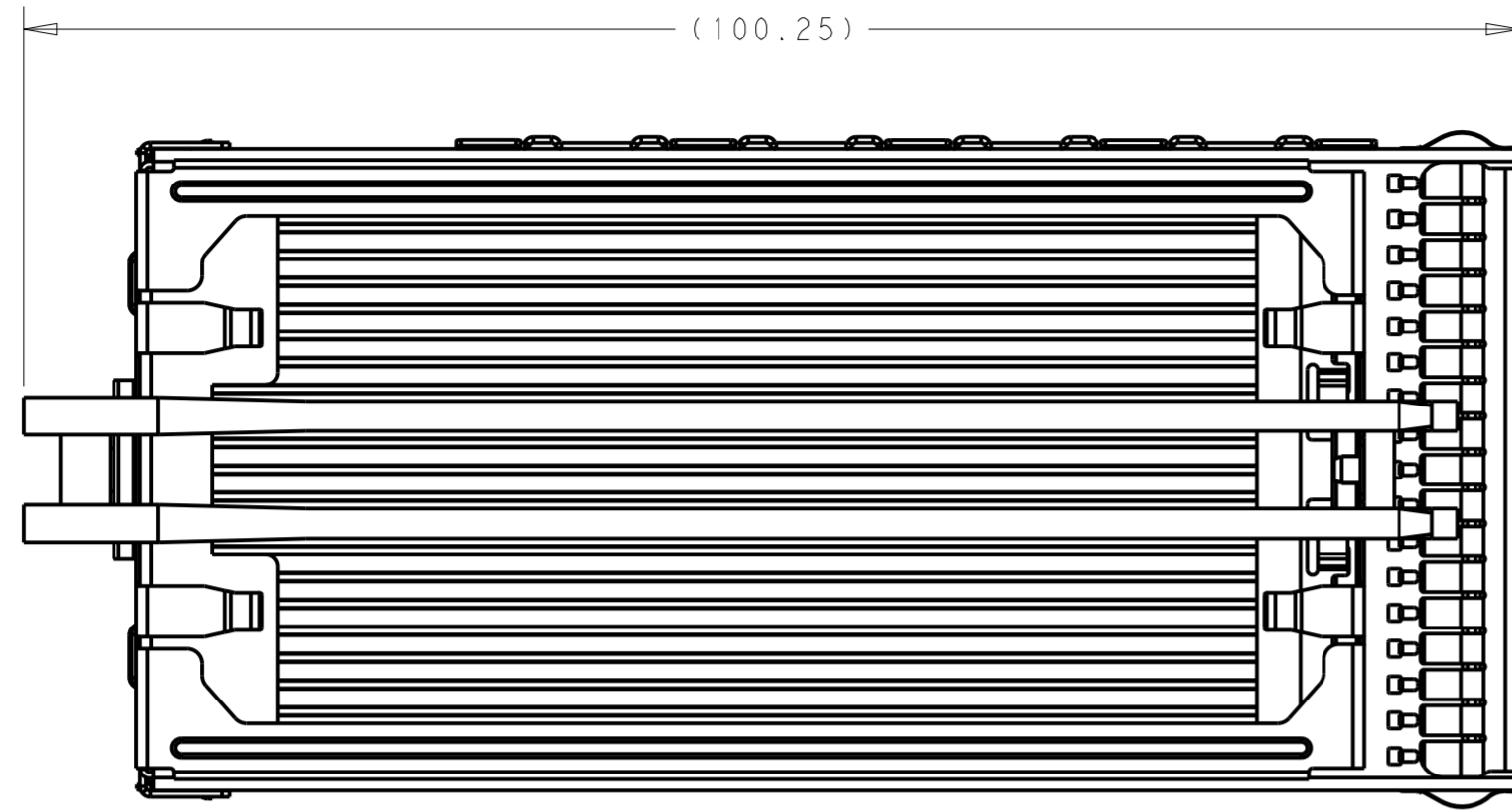

2314914-2 AS SHOWN
SCALE 3:2

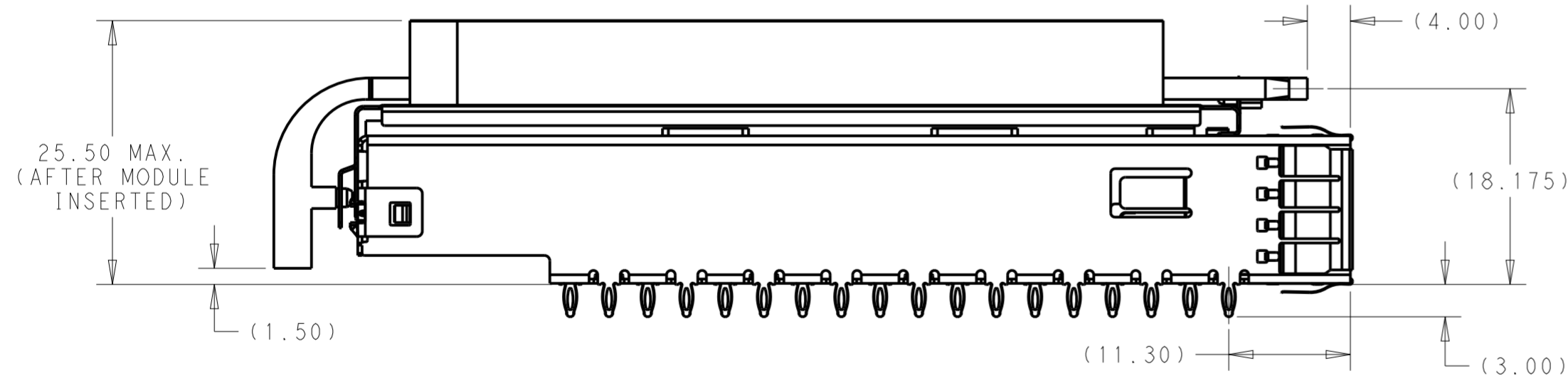

SCALE 2:1

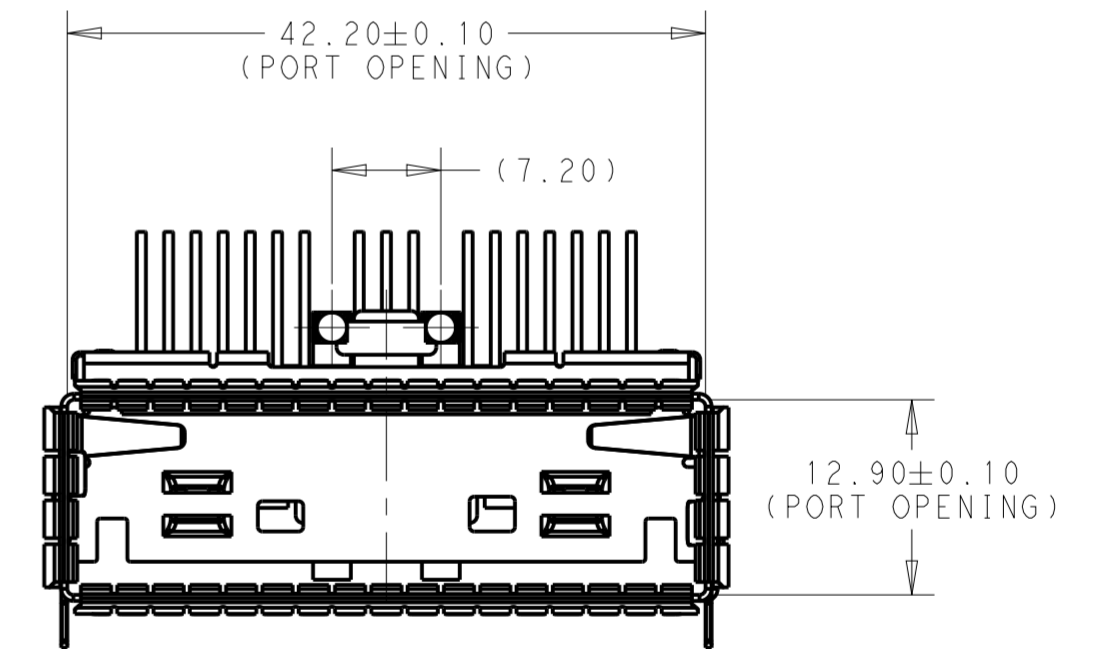

THIS DRAWING IS A CONTROLLED DOCUMENT.		DWN ANDY XIE 28DEC2016	TE Connectivity	
		CHK SEAN HAN 28DEC2016		
		APVD SEAN HAN 28DEC2016		
		PRODUCT SPEC		
DIMENSIONS:	TOLERANCES UNLESS OTHERWISE SPECIFIED:	108-32103	NAME HARD WARE KITS WIHT LP	
mm	0 PLC ±	APPLICATION SPEC	CFP2 1X1	
	1 PLC ±0.25	114-32145	SIZE	CAGE CODE
	2 PLC ±0.15	WEIGHT	A2	-
	3 PLC ±0.10	CUSTOMER DRAWING	DRAWING NO G-2314979	
	4 PLC ±0.05		RESTRICTED TO	
	ANGLES ±		SCALE	1:1
	FINISH		SHEET	3 OF 7
MATERIAL			REV	A

THIS DRAWING IS UNPUBLISHED. RELEASED FOR PUBLICATION 20
 © COPYRIGHT 20 BY - ALL RIGHTS RESERVED.

REVISIONS				
P	LTR	DESCRIPTION	DATE	APVD
-		SEE SHEET 1	-	-

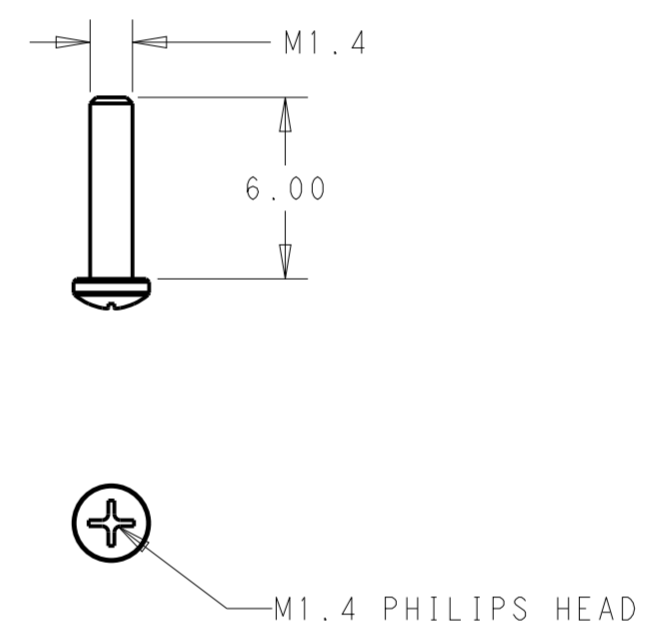
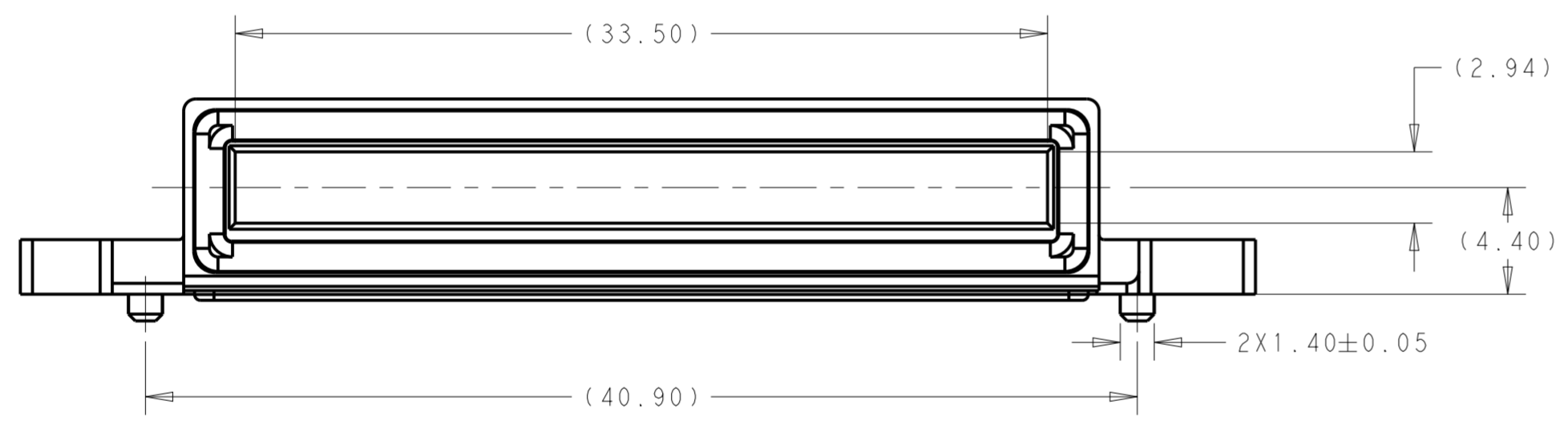
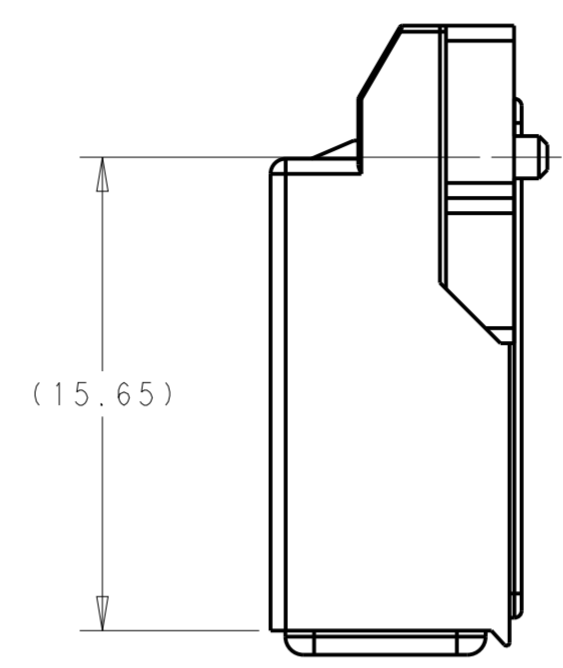
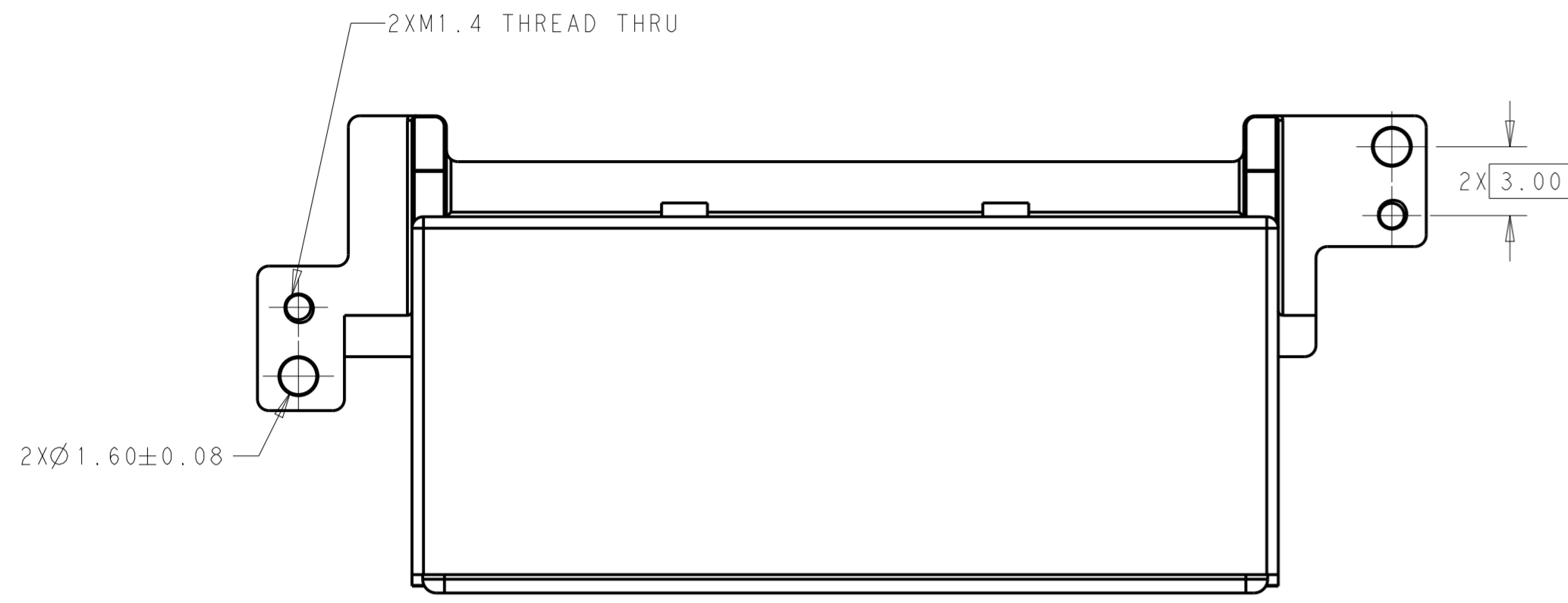

SCALE 4:1

2292789-1 AS SHOWN

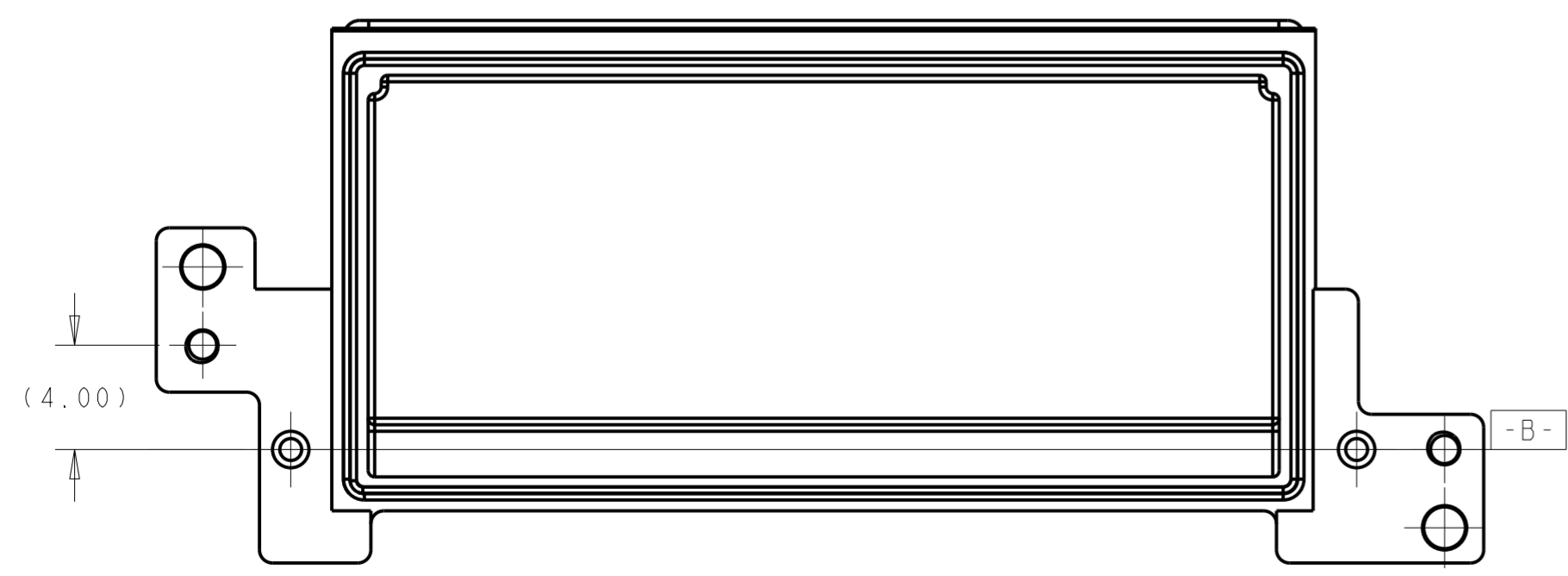

2274846-1 AS SHOWN

THIS DRAWING IS A CONTROLLED DOCUMENT.		DWN ANDY.XIE 28DEC2016	TE Connectivity	
DIMENSIONS: mm		CHK SEAN.HAN 28DEC2016		
TOLERANCES UNLESS OTHERWISE SPECIFIED:		APVD SEAN.HAN 28DEC2016	NAME HARD WARE KITS WIHT LP	
0 PLC ±		PRODUCT SPEC 108-32103	CFP2 1X1	
1 PLC ±0.25		APPLICATION SPEC 114-32145	SIZE A2	CAGE CODE -
2 PLC ±0.15		WEIGHT -	DRAWING NO C-2314979	RESTRICTED TO -
3 PLC ±0.1		CUSTOMER DRAWING	SCALE 4:1	SHEET 4 OF 7
4 PLC ±0.05			REV A	
ANGLES ±1				
FINISH				
MATERIAL SEE NOTES				
SEE NOTES				

THIS DRAWING IS UNPUBLISHED. RELEASED FOR PUBLICATION 20
 © COPYRIGHT 20 BY - ALL RIGHTS RESERVED.

REVISIONS					
P	LTR	DESCRIPTION	DATE	DWN	APVD
-	-	SEE SHEET 1	-	-	-

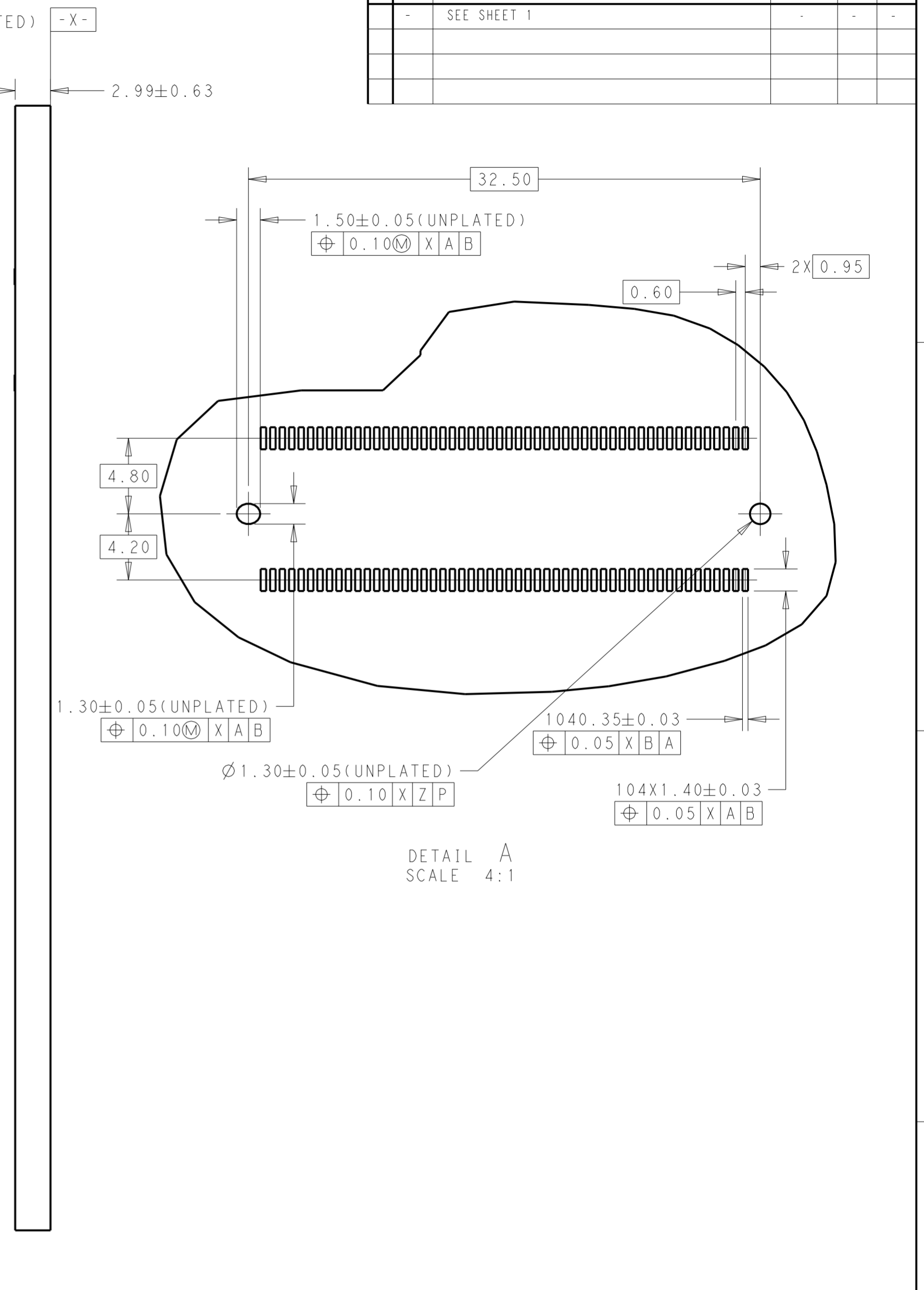
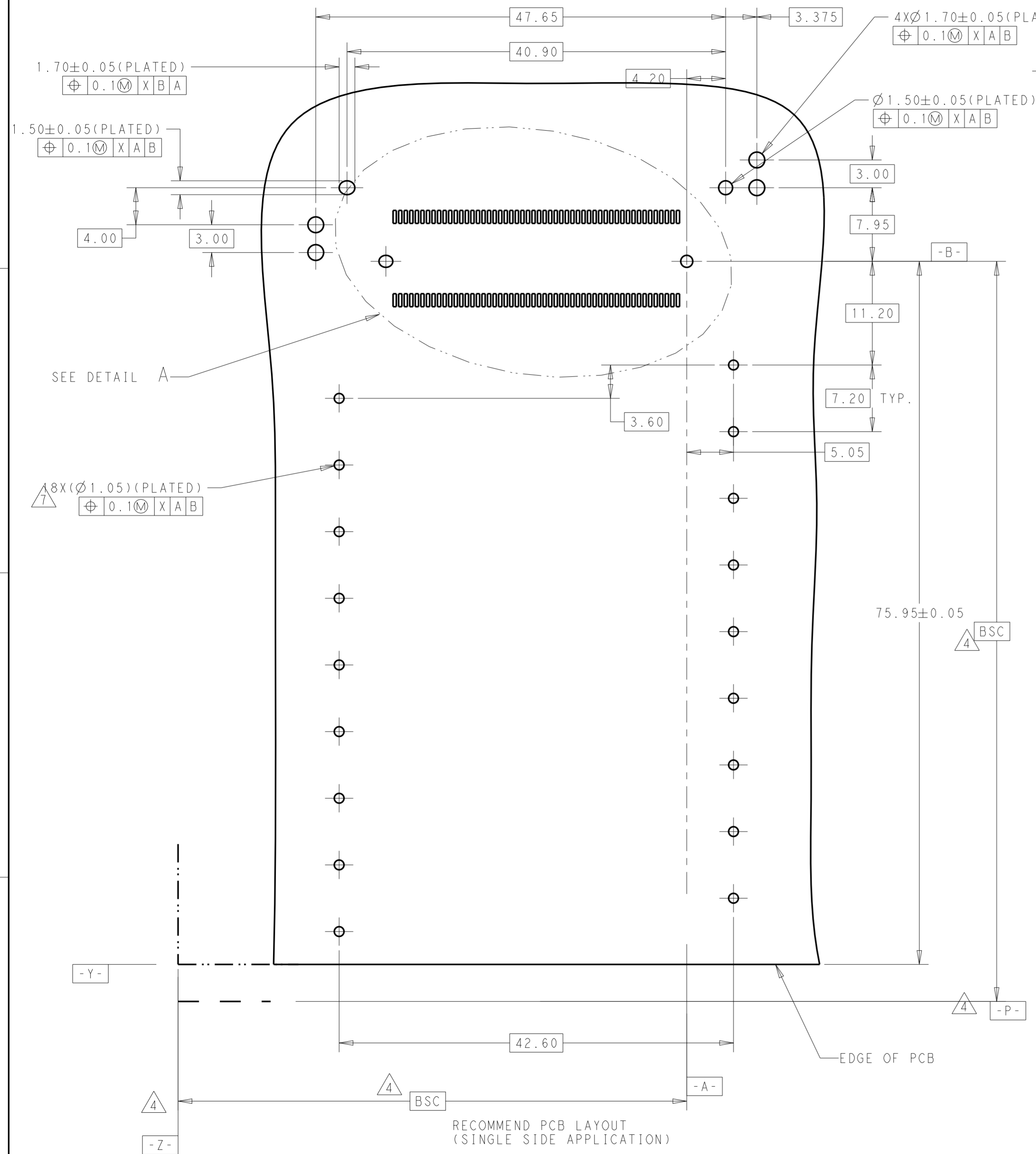

DETAIL A
SCALE 4:1

RECOMMEND PCB LAYOUT
(SINGLE SIDE APPLICATION)

THIS DRAWING IS A CONTROLLED DOCUMENT.		DWN ANDY.XIE 28DEC2016	TE Connectivity	
DIMENSIONS: mm		CHK SEAN.HAN 28DEC2016		
TOLERANCES UNLESS OTHERWISE SPECIFIED:		APVD SEAN.HAN 28DEC2016	NAME HARD WARE KITS WIHT LP CFP2 1X1	
0 PLC ±	1 PLC ±0.25	PRODUCT SPEC -	SIZE A2	CAGE CODE -
2 PLC ±0.15	3 PLC ±0.1	APPLICATION SPEC -	DRAWING NO. C-2314979	RESTRICTED TO -
4 PLC ±0.05	ANGLES ±1	WEIGHT -	SCALE 3:1	SHEET 5 OF 7
MATERIAL SEE NOTES	FINISH SEE NOTES	CUSTOMER DRAWING	REV A	

THIS DRAWING IS UNPUBLISHED. RELEASED FOR PUBLICATION 20
 © COPYRIGHT 20 BY - ALL RIGHTS RESERVED.

REVISIONS				
P	LTR	DESCRIPTION	DATE	APVD
-	-	SEE SHEET 1	-	-

CROSS-HATCHED DENOTES COMPONENT AND TRACE KEEP-OUT AREA (EXCEPT CHASSIS GROUND) FOR NON-MAYLARTAPE APPLICATION. COMPONENTS AND TRACES ARE ONLY ALLOWED FOR APPLICATION WITH MYLAR TAPE

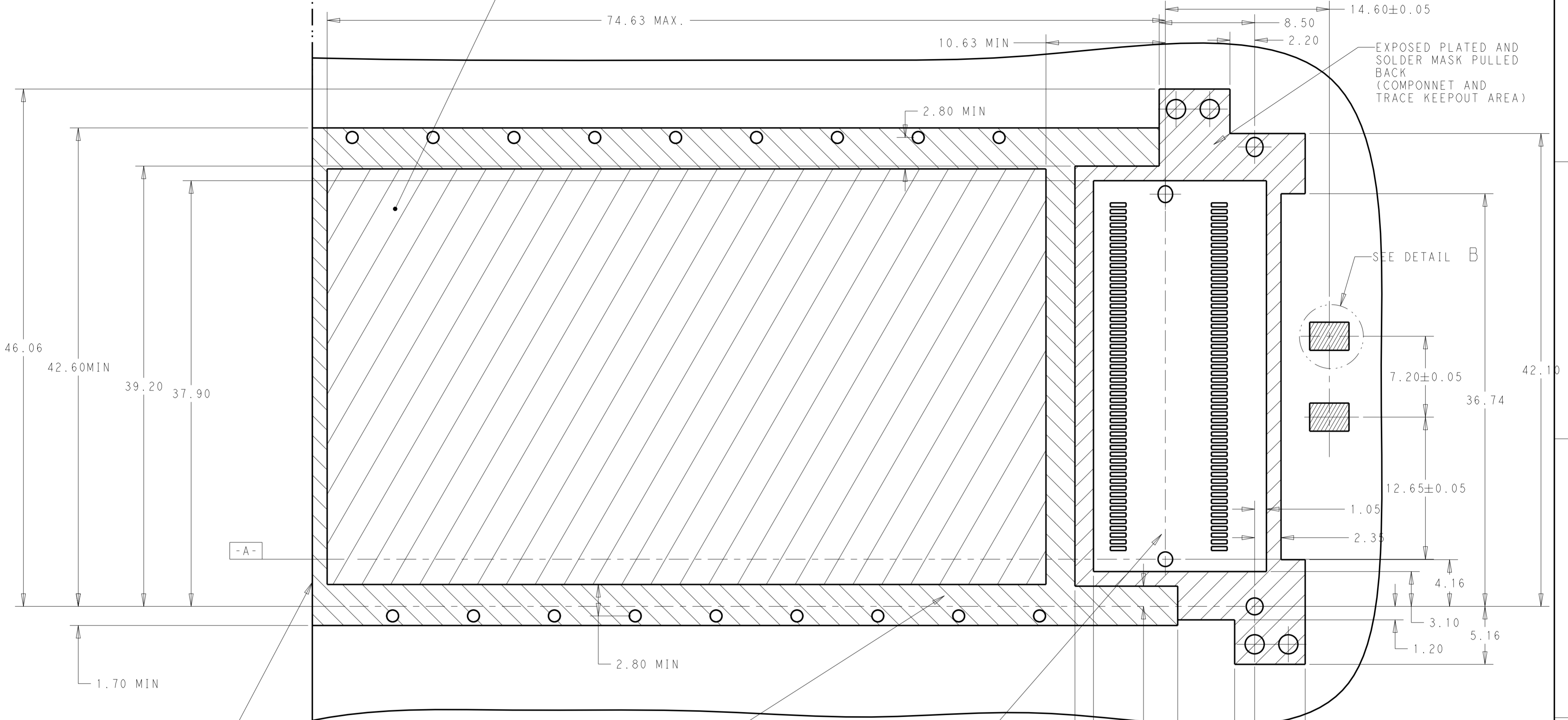

EXPOSED PLATED AND SOLDER MASK PULLED BACK (COMPONENT AND TRACE KEEPOUT AREA)

SEE DETAIL B

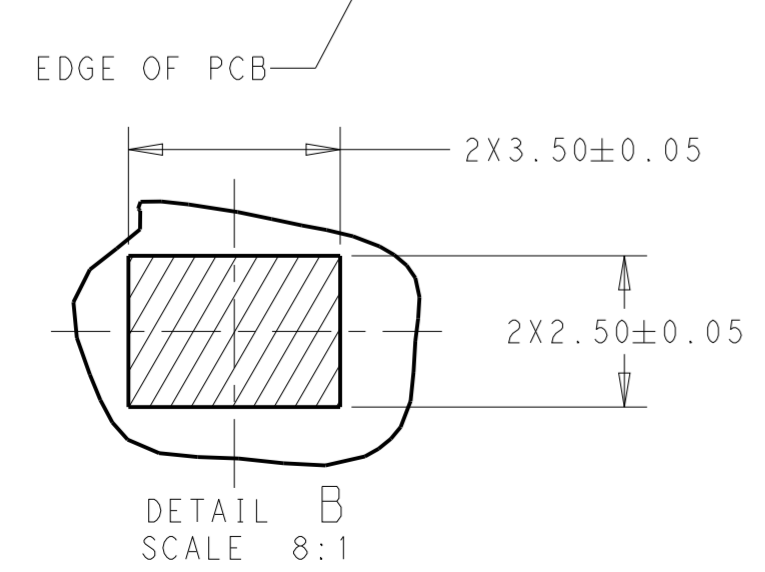

CROSS-HATCHED DENOTES COMPONENT AND TRACE KEEP-OUT AREA (EXCEPT CHASSIS GROUND)
 COMPONENT KEEP-OUT AREA (TRACE ALLOWED)

THIS DRAWING IS A CONTROLLED DOCUMENT.		DWN ANDY.XIE 28DEC2016	STE TE Connectivity	
		CHK SEAN.HAN 28DEC2016		
		APVD SEAN.HAN 28DEC2016	NAME HARD WARE KITS WIHT LP CFP2 1X1	
DIMENSIONS: mm		TOLERANCES UNLESS OTHERWISE SPECIFIED:	SIZE CAGE CODE DRAWING NO RESTRICTED TO	
0 PLC ±0.10		1 PLC ±0.10	A2 - C-23149799	
2 PLC ±0.10		2 PLC ±0.10	SCALE 1:1 SHEET 6 OF 7 REV A	
3 PLC ±0.10		3 PLC ±0.10		
4 PLC ±0.05		4 PLC ±0.05		
ANGLES ±1		FINISH		
MATERIAL SEE NOTES		FINISH SEE NOTES		
		CUSTOMER DRAWING		

THIS DRAWING IS UNPUBLISHED. RELEASED FOR PUBLICATION 20
 © COPYRIGHT 20 BY - ALL RIGHTS RESERVED.

REVISIONS				
P	LTR	DESCRIPTION	DATE	APVD
-	-	SEE SHEET 1	-	-

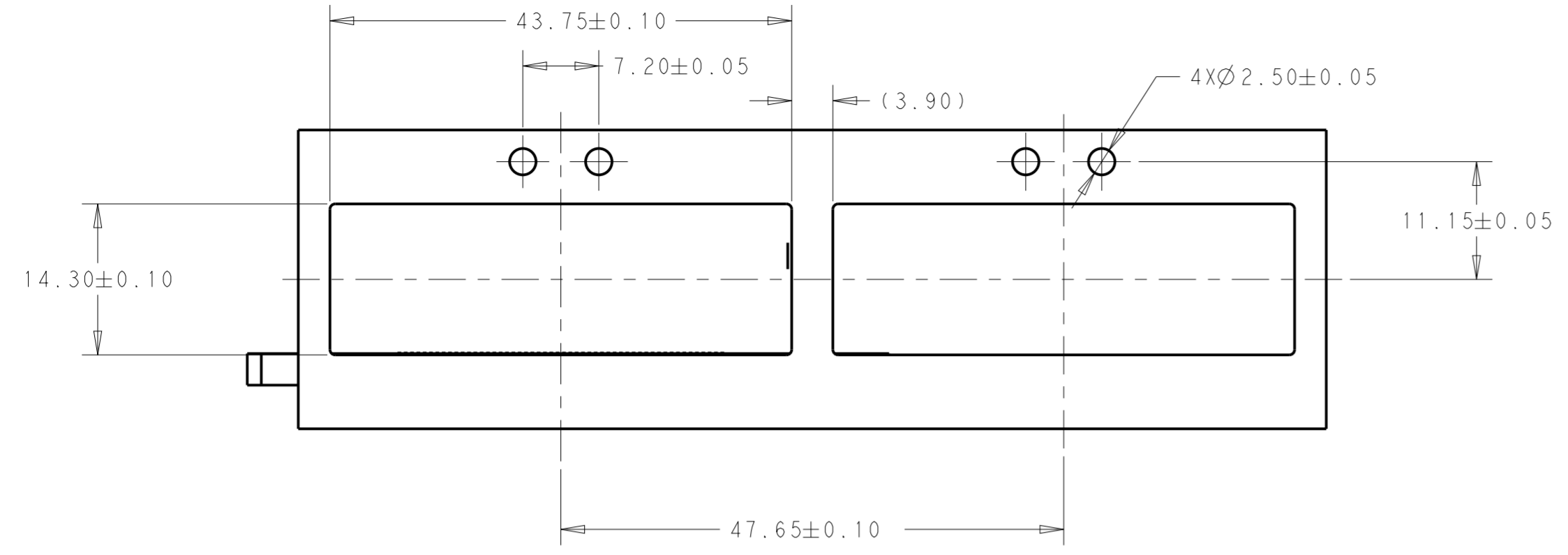

SCALE 2:1

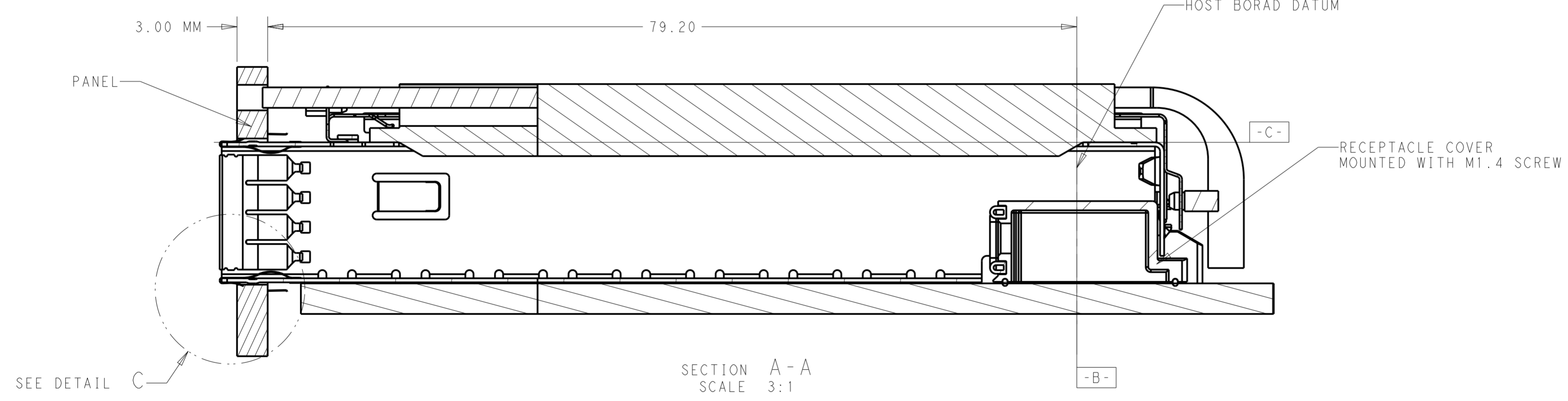
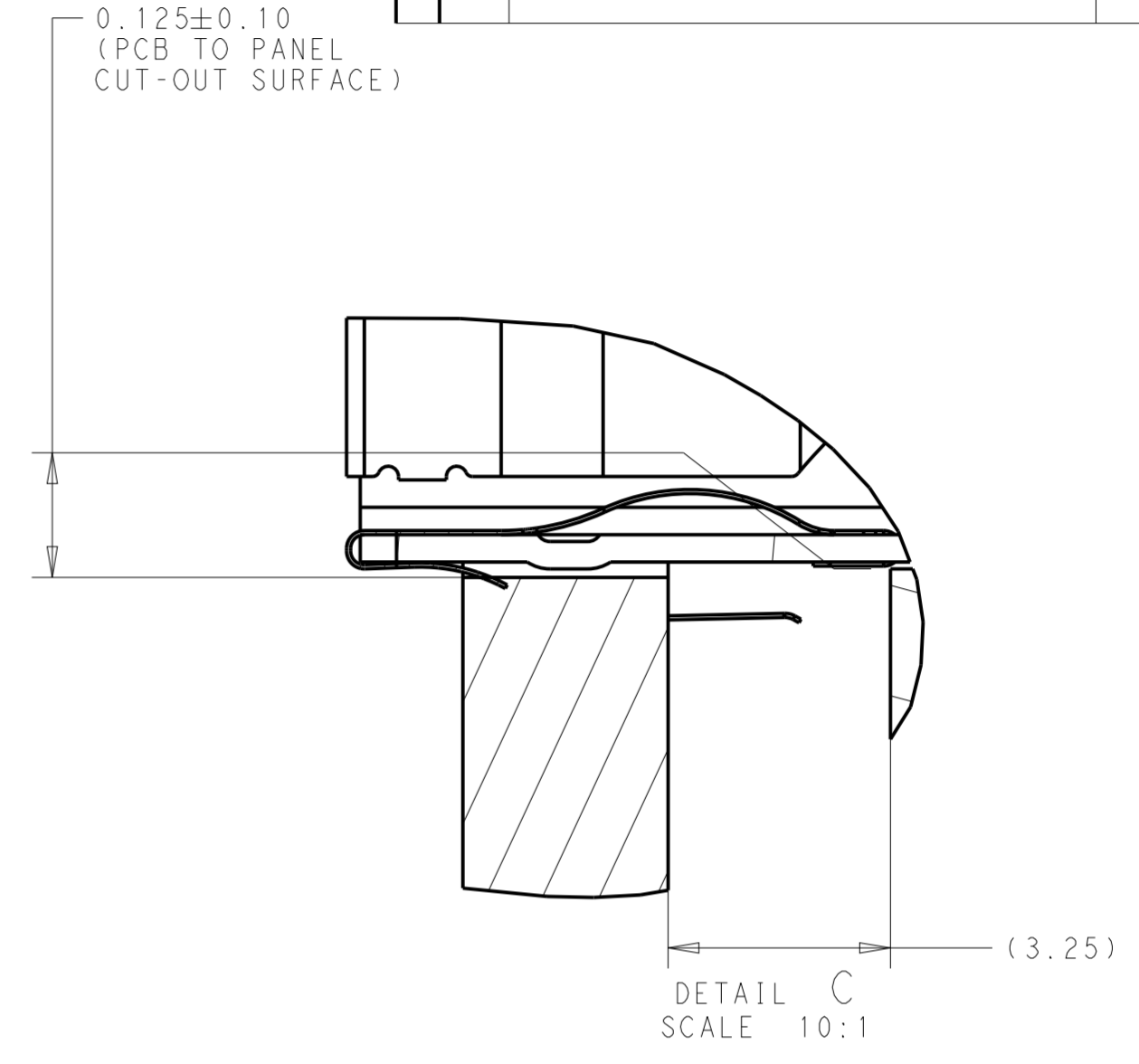

THIS DRAWING IS A CONTROLLED DOCUMENT.		DWN ANDY.XIE 28DEC2016	STE TE Connectivity	
DIMENSIONS: mm		CHK SEAN.HAN 28DEC2016		
TOLERANCES UNLESS OTHERWISE SPECIFIED:		APVD SEAN.HAN 28DEC2016	NAME HARD WARE KITS WIHT LP CFP2 1X1	
0 PLC ±	1 PLC ±0.25	PRODUCT SPEC -	SIZE A2	CAGE CODE -
2 PLC ±0.15	3 PLC ±0.1	APPLICATION SPEC -	DRAWING NO. C-2314979	RESTRICTED TO -
4 PLC ±0.05	ANGLES ±1	WEIGHT -	SCALE 1:1	SHEET 7 OF 7
MATERIAL SEE NOTES	FINISH SEE NOTES	CUSTOMER DRAWING	REV A	

单击下面可查看定价，库存，交付和生命周期等信息

[>>TE Connectivity\(泰科\)](#)