

THIS DRAWING IS UNPUBLISHED. RELEASED FOR PUBLICATION, 19 .
 © COPYRIGHT 19 BY AMP INCORPORATED. ALL RIGHTS RESERVED.

LOC	DIST	REVISIONS			
P	LTR	DESCRIPTION	DATE	DWN	APVD
AJ	16	F	REDWN AND REV PER EC 0220-0720-95	15FEB96	MEC FPM
		G	REVISED PER 0503-0155-96	12-6-96	JG FM

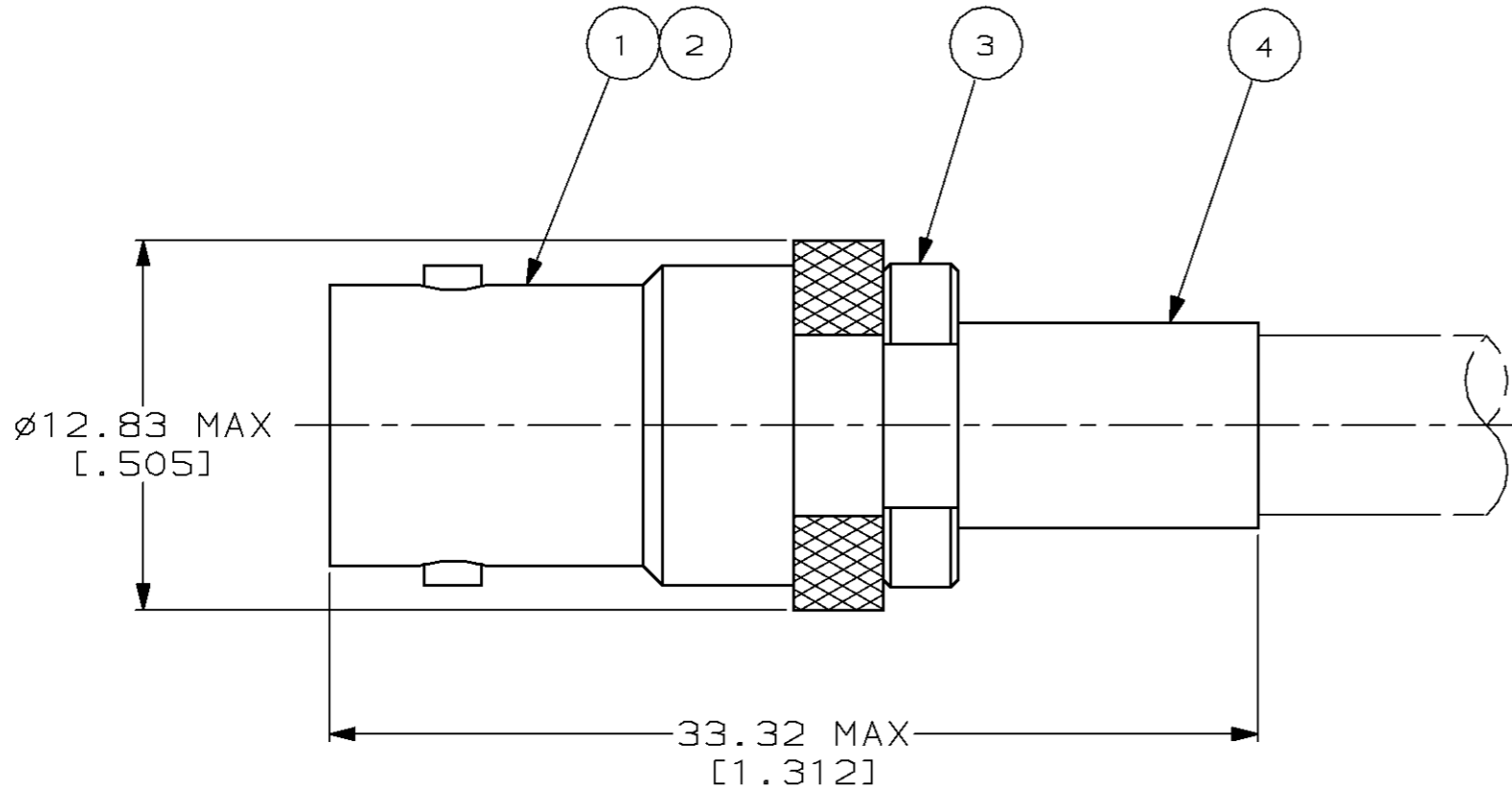

- USE INSTRUCTION SHEET 1799-2
- USE CRIMP TOOL 69141-1 WITH CABLE RG-59/U, 59A/U, 59B/U, 62/U, 62A/U, 62B/U, 124/U, 140/U AND 210/U

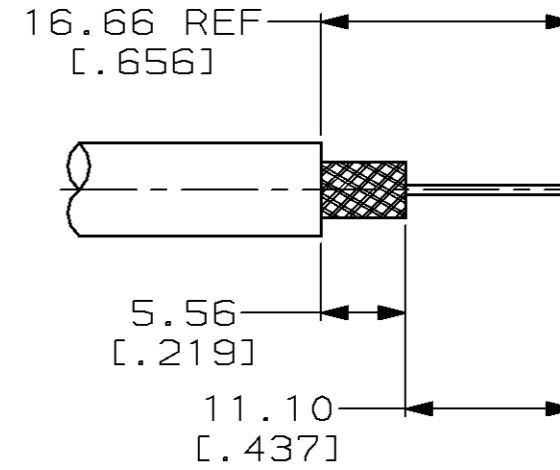

RECOMMENDED STRIP LENGTH
SCALE 2:1

OBSOLETE	-	-	-	-	2-329063-2
△2	329041	50793-2	2-329106-1	329061	2-329063-1
OBSOLETE	-	-	-	-	329063
④	FERRULE QTY=1	③	CRIMP END ASSEMBLY QTY=1	②	GASKET QTY=1
				①	JACK ASSEMBLY QTY=1
					PART NUMBER

THIS DRAWING IS A CONTROLLED DOCUMENT.

DIMENSIONS: mm [INCHES]	TOLERANCES UNLESS OTHERWISE SPECIFIED:	DWN MICHAEL E. COWHER 06FEB96	AMP AMP Incorporated Harrisburg, PA 17105-3608
	0 PLC ±- 1 PLC ±- 2 PLC ±0.41 [.016] 3 PLC ±- 4 PLC ±- ANGLES ±-	CHK FRANK P. MORANA 15FEB96	
MATERIAL	FINISH	APVD FRANK P. MORANA 15FEB96	NAME JACK, BNC
		PRODUCT SPEC	SIZE A3
		APPLICATION SPEC	CAGE CODE 00779
		WEIGHT	DRAWING NO C-329063
		CUSTOMER DRAWING	SCALE 4:1
			SHEET 1 OF 1
			REV G

单击下面可查看定价，库存，交付和生命周期等信息

[>>TE Connectivity\(泰科\)](#)