

THIS DRAWING IS UNPUBLISHED. RELEASED FOR PUBLICATION  
 © COPYRIGHT BY TYCO ELECTRONICS CORPORATION. ALL RIGHTS RESERVED.

LOC	DIST	REVISIONS					
HC	00	P	LTR	DESCRIPTION	DATE	DWN	APVD
		A		REV PER ECO 06-002539	07APR06	GB	JH

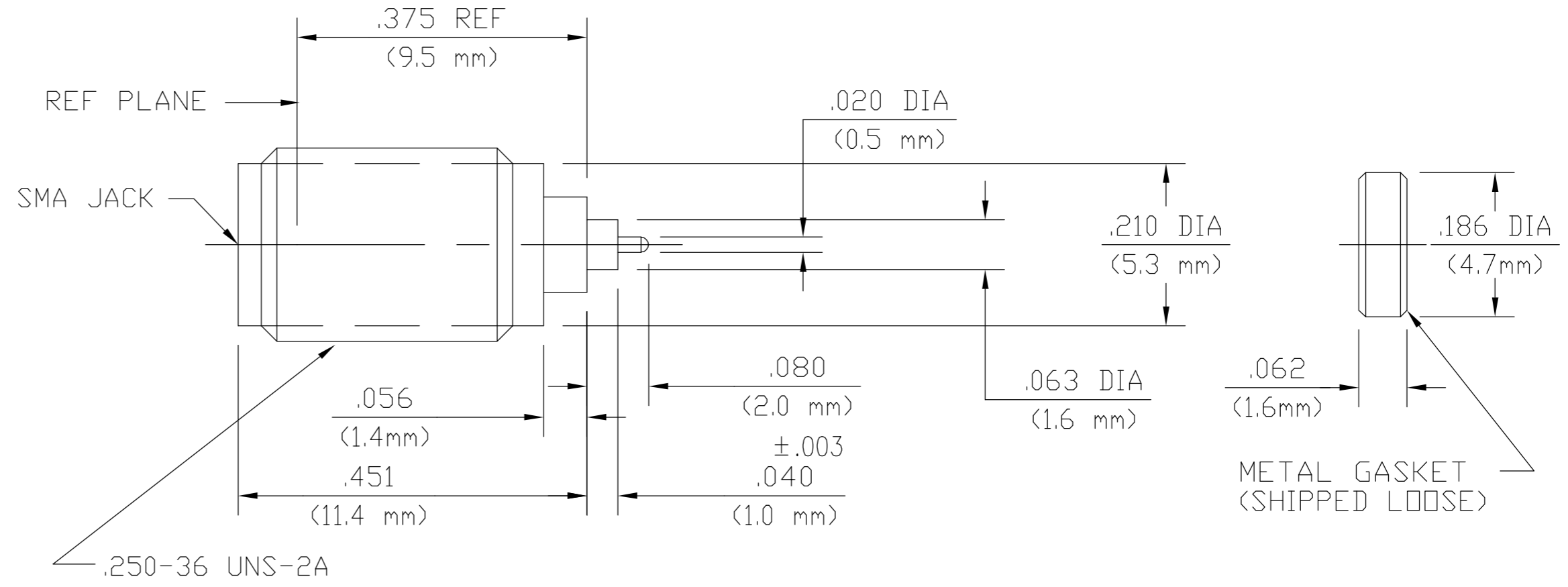
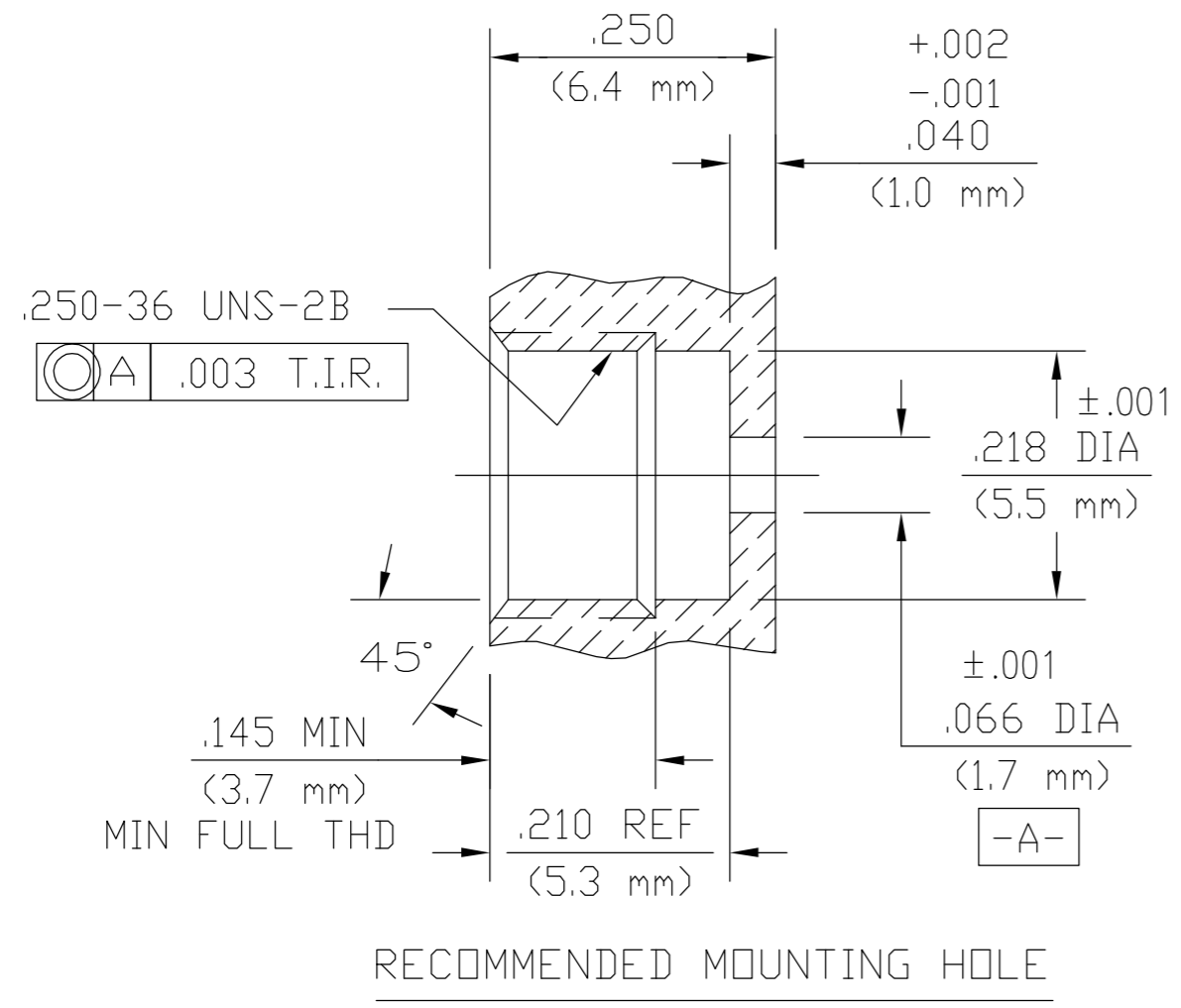

6053226-1  
 PART NUMBER

ELECTRICAL	MECHANICAL	ENVIRONMENTAL
Nominal Impedance (Ohms) 50	Interface Dimensions MIL-STD-348A	TEMPERATURE RATING -65°C TO +125°C
Frequency Range (GHz) DC - 26.5	FIG 310.2	Vibration - MIL-STD-202, Method 204, Condition D, 20G's
Volt Rating (VRMS MAX) 335 @ Sea Level	Recommended Mating Torque N/A	Shock - MIL-STD-202, Method 213, Condition I
VSWR 1.04 + (.009 F(GHz))	Mating Characteristics:	Thermal Shock MIL-STD-202, Method 107, Condition B
Insertion Loss (dB MAX) .05√F(GHz)	Insertion (MAX Lbs) 3.0	EXCEPT HIGH TEMP 115°C
RF Leakage (dB MIN) -(100 - F(GHz))	Withdrawal (MIN Oz) 1.0	Moisture Resistance - MIL-STD-202, Method 106
Corona, 70,000 Ft (VRMS MIN) 333	Force To Engage (In/Lbs MAX) 2.0	Corrosion - MIL-STD-202, Method 101, Condition B, 5% salt spray
Dielectric Withstanding Voltage (VRMS MIN) 1000 @ Sea Level	Force To Disengage (In/Lbs MAX) 2.0	Leak Test - MIL-STD-202, Method 112, Condition C, Procedure I, 1 x 10 CC/Sec
Contact Resistance (Milliohms MAX)	Center Contact Captivation	
Center Contact 10.0	Axial 6.0 Lbs	
Outer Contact 2.0	Radial N/A	
RF High Potential (VRMS MIN @ 5 MHz) 670 @ Sea Level	Weight (Grams) T.B.D.	
I.R.(Megohms) 5000		

COMPONENT	MATERIAL	FINISH
HOUSING	STAINLESS STEEL PER ASTM-A484 AND ASTM-A582, TYPE 303	GOLD PLATE PER ASTM B 488
DIELECTRIC	TFE FLUOROCARBON PER ASTM D 1710	N/A
CTR CONTACT	BERYLLIUM COPPER PER ASTM B196	GOLD PLATE PER ASTM B 488
CONTACT EXT	IRON-NICKEL-COBALT ALLOY PER MIL-I-23011 (KOVAR)	GOLD PLATE PER ASTM B 488
METAL GASKET	SAE C12L14 STEEL	SILVER PLATE PER ASTM B 700
HERMETIC SEAL	GLASS BEAD	N/A

THIS DRAWING IS A CONTROLLED DOCUMENT.

DIMENSIONS: INCHES (mm)	TOLERANCES UNLESS OTHERWISE SPECIFIED:	DWN M.Y. 18APR91	Tyco Electronics Corporation Harrisburg, PA 17105-3608
0 PLC ± -	1 PLC ± -	CHK C.W. 18APR91	
	2 PLC ± -	APVD G.D.D. 18APR91	NAME
	3 PLC ± .005	PRODUCT SPEC	SMA PANEL FEEDTHRU JACK RECEPTACLE HERMETICALLY SEALED (2058-5119-00)
MATERIAL SEE NOTES	FINISH SEE NOTES	APPLICATION SPEC 408-4847	SIZE CAGE CODE DRAWING NO RESTRICTED TO
		WEIGHT -	A2 00779 C=6053226
		CUSTOMER DRAWING	SCALE 5:1 SHEET 1 of 1 REV A

单击下面可查看定价，库存，交付和生命周期等信息

[>>TE Connectivity\(泰科\)](#)