

LOC	DIST	REVISIONS				
P	LTR	DESCRIPTION	DATE	DWN	APVD	
H	-	A	RELEASE FOR PRODUCTION	29FEB2008	PW	DH
		B	ECR-11-006667	19APR2011	PW	DH

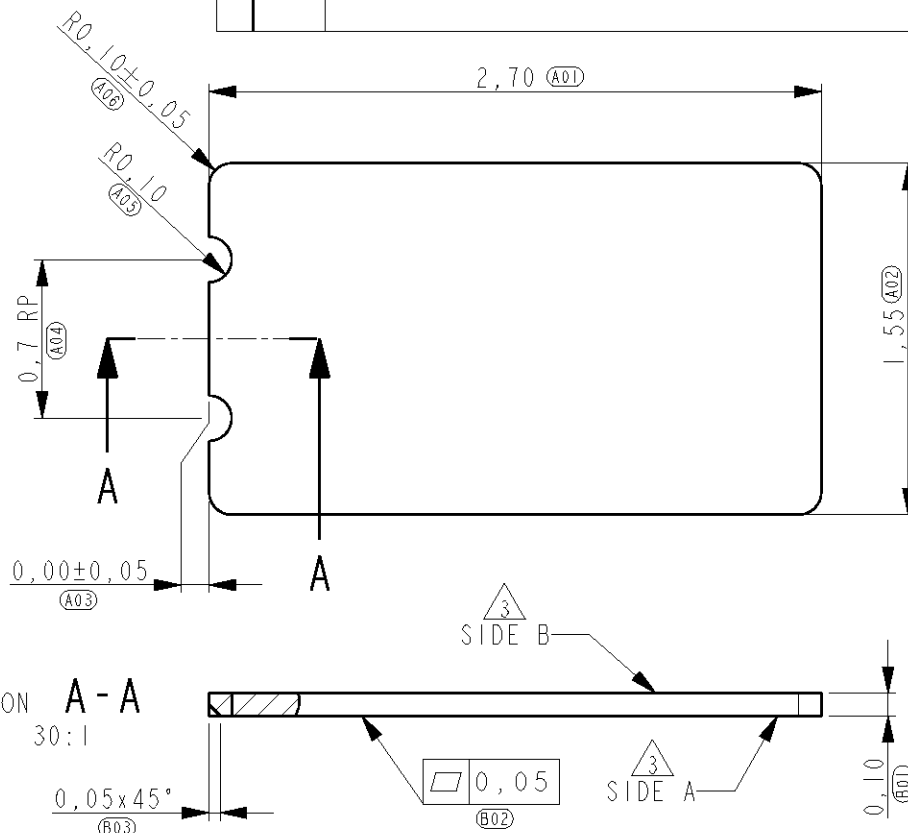

SECTION A-A
SCALE 30:1

NOTES:

- 1 PART NUMBER AS SHOWN: 1982534-3.
- 2 DRAWING REPRESENTS PART VERSION "VI"
- 3 PLATING:
 1,27µm MIN. NICKEL ALL OVER.
 SIDE A (SOLDER SURFACE): 0,05 - 0,20µm GOLD.
 0,40µm MAX. GOLD AT 0,20mm FROM THE EDGE.
 SIDE B (CONTACT SURFACE): 0,50µm MIN. GOLD.
- 4 NMP CODE: 5900017.
- 5 PRODUCTS PASS 2 HOUR ACID TEST ACC. TO NOKIA SPECIFICATION DTY08136-EN.
- 6 SOLDER SURFACE MARKED WITH SMALL STAMPED LETTER "L" FOR IDENTIFICATION OF PLATED SURFACE.

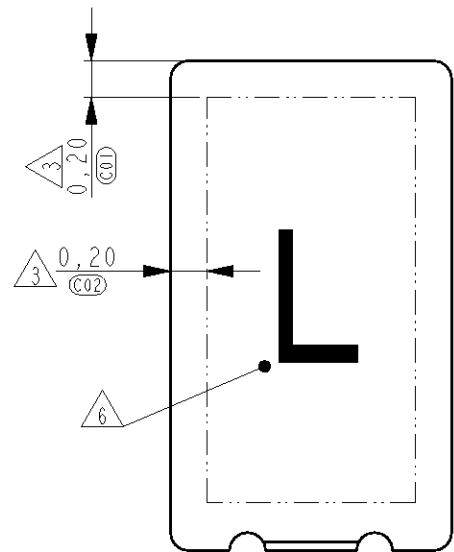

RELEASED FOR PUBLICATION

ALL RIGHTS RESERVED.

BY -

COPYRIGHT -

THIS DRAWING IS UNPUBLISHED.

DIMENSIONS: mm	DWN P.Willems	04-MAY-07	MATERIAL	Cu ALLOY	FINISH	3 -
	CHK H.d.Otter	04-MAY-07	TE TE Connectivity			
TOLERANCES UNLESS OTHERWISE SPECIFIED:	APVD D.Halberstadt	04-MAY-07				
0 PLC ±-	PRODUCT SPEC		SIZE	CAGE CODE	DRAWING NO	RESTRICTED TO
1 PLC ±0,2	-		A 4	00779	C-1982534	-
2 PLC ±0,1	APPLICATION SPEC		WEIGHT		3,6 mg	CUSTOMER DRAWING
3 PLC ±-	-		SCALE		30:1	SHEET 1 OF 2
4 PLC ±-	-		REV		B	
ANGLES ±-	-		SCALE		30:1	SHEET 1 OF 2

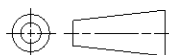

LOC	DIST	REVISIONS					
		P	LTR	DESCRIPTION	DATE	DWN	APVD
H	-	-	-	SEE SHEET 1	-	-	-

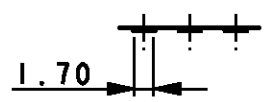
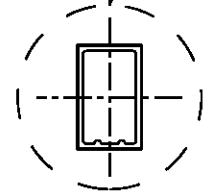
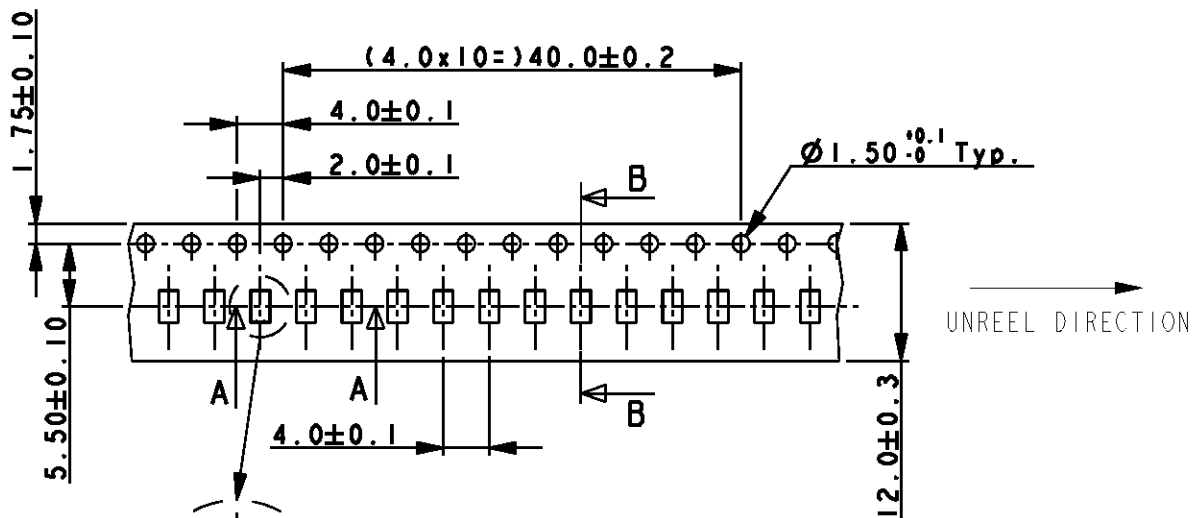

SECTION A-A

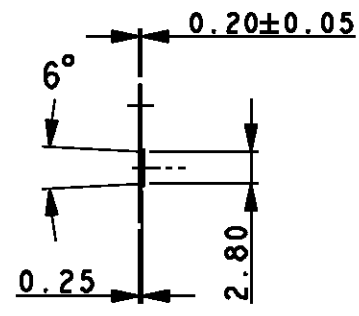

SECTION B-B

NOTES:

- 1 REEL DIMENSIONS: 330x100x12,4mm.
- 2 QUANTITY PER REEL: 20000 PIECES.

THIS DRAWING IS UNPUBLISHED. BY - ALL RIGHTS RESERVED. COPYRIGHT -

DIMENSIONS: mm	DWN P.Willems	04-MAY-07	MATERIAL	Cu ALLOY	FINISH	-
	CHK H.d.Otter	04-MAY-07	TE Connectivity			
TOLERANCES UNLESS OTHERWISE SPECIFIED:	APVD D.Halberstadt	04-MAY-07				
0 PLC ±-	PRODUCT SPEC	-	SIZE	CAGE CODE	DRAWING NO	RESTRICTED TO
1 PLC ±0,2	APPLICATION SPEC	-	A 4	00779	©=1982534	-
2 PLC ±0,1	WEIGHT	3,6 mg	CUSTOMER DRAWING			
3 PLC ±-			SCALE	30:1	SHEET	2 OF 2
4 PLC ±-					REV	B
ANGLES ±-						

单击下面可查看定价，库存，交付和生命周期等信息

[>>TE Connectivity\(泰科\)](#)