

LOC	DIST	REVISIONS					
		P	LTR	DESCRIPTION	DATE	DWN	APVD
GP	00	M1		REVISED PER ECO-11-004835	11MAR11	RK	HMR

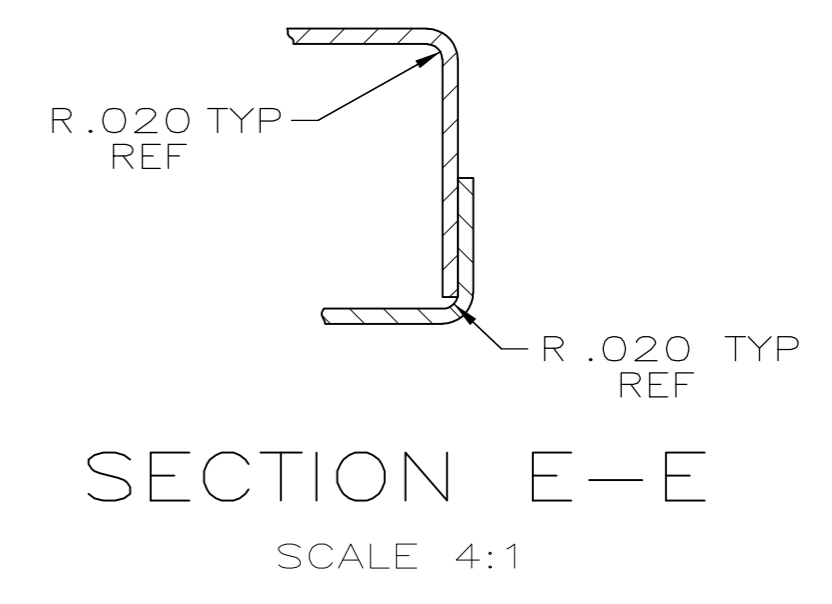
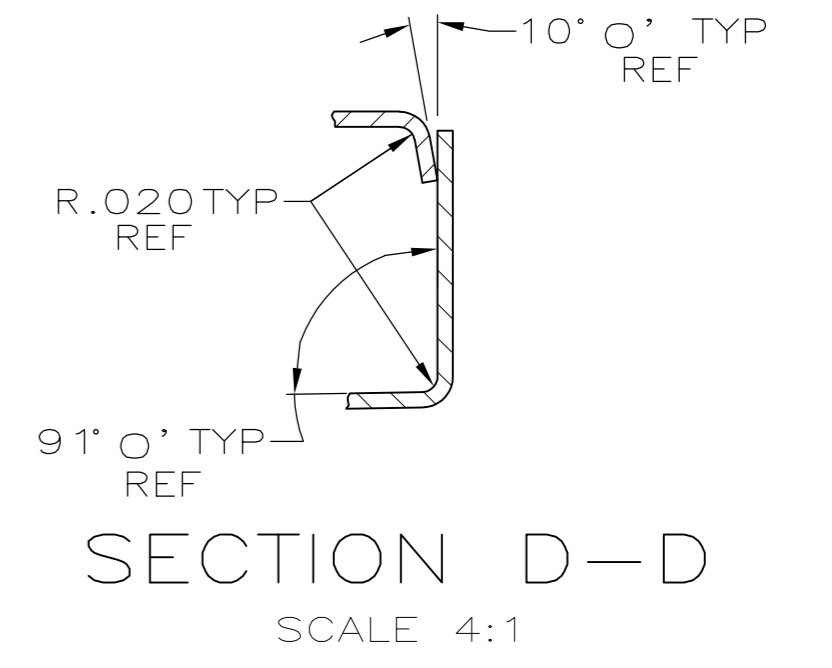
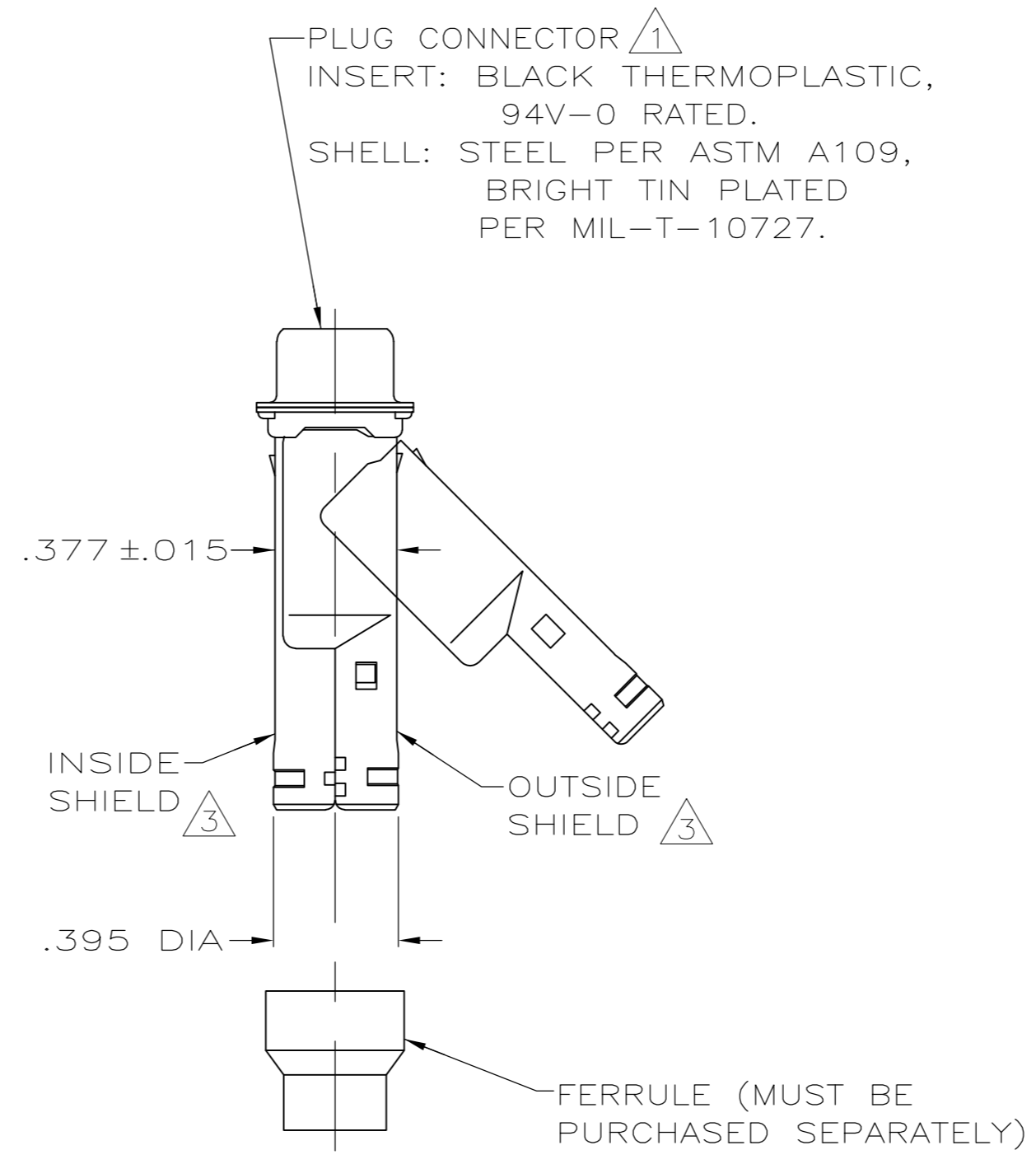
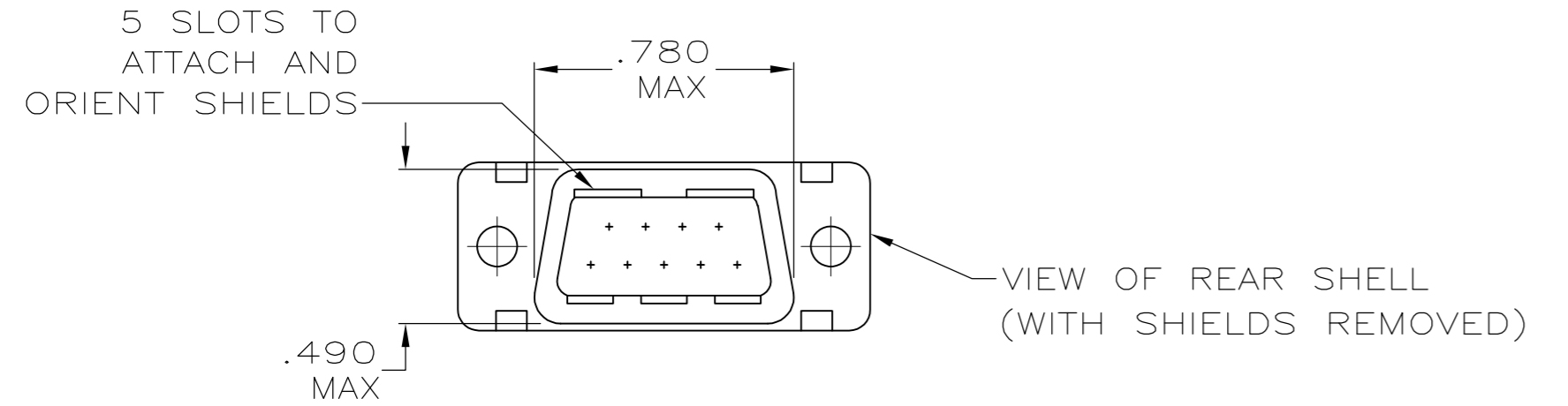
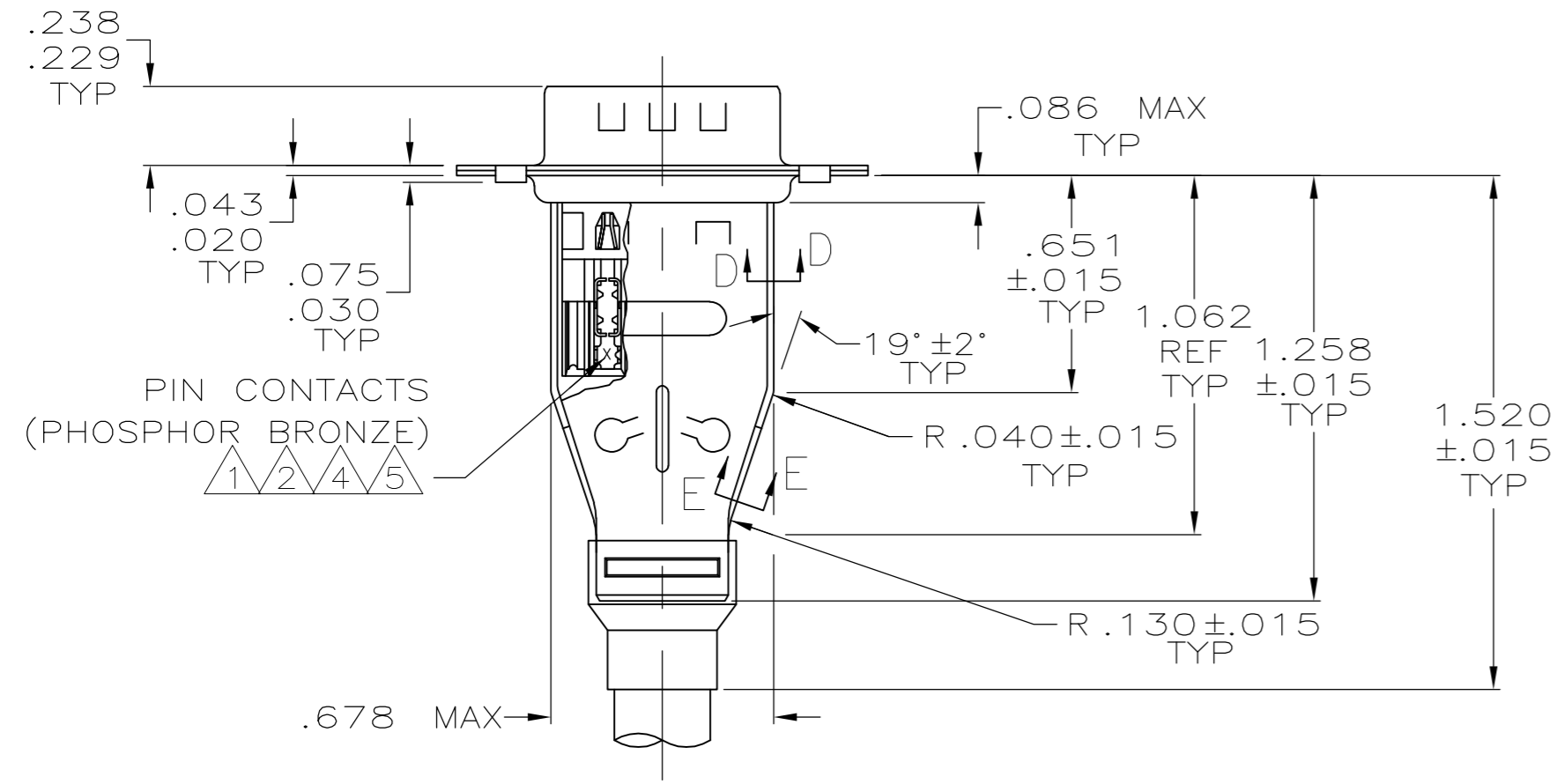
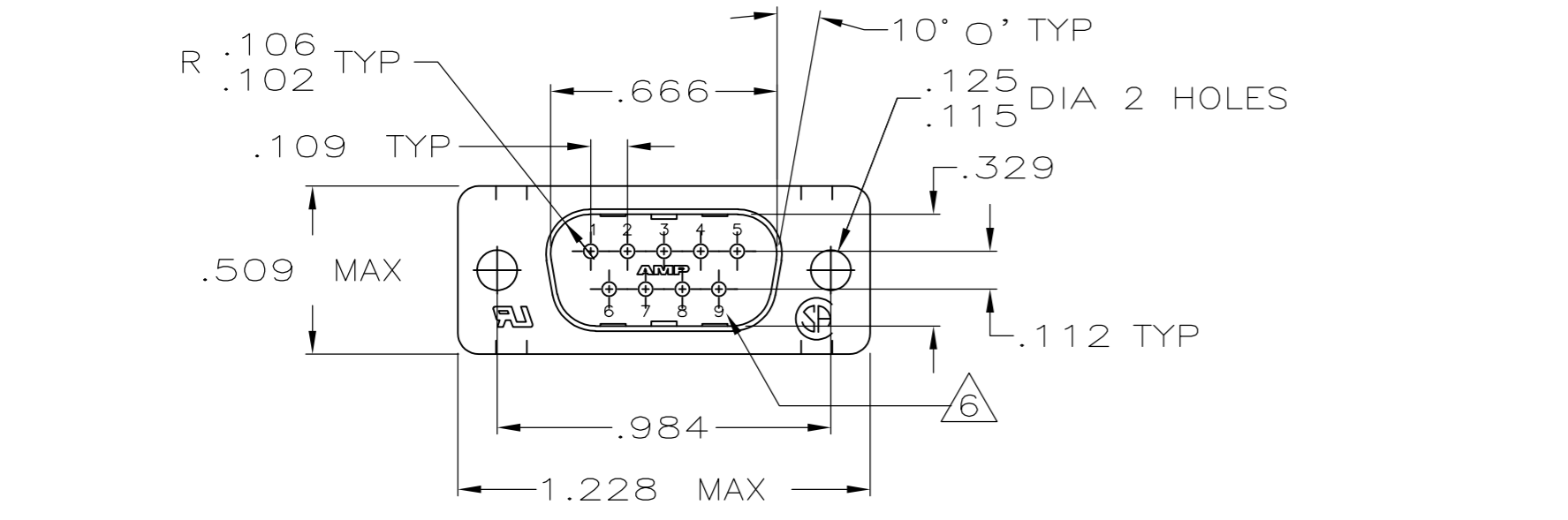

- ⚠️ PLUG CONNECTOR FULLY LOADED WITH CONTACTS. ALL OTHER PARTS SHIPPED UNASSEMBLED (EACH PART INDIVIDUALLY BULK PACKED).
- ⚠️ NUMBER ON CONTACT INDICATES WIRE RANGE.
- ⚠️ SHIELDS: MATERIAL—.020 THICK STEEL, TIN PLATED.
- ⚠️ CONTACTS PLATED GOLD PLATED FOR LENGTH OF .150 MIN FROM MATING END, .000030 MIN GOLD IN MATED AREA. .000100—.000200 BRIGHT TIN OR BRIGHT IN TIN-LEAD IN WIRE TERMINATION AREA. .000050 NICKEL UNDERPLATE ON ENTIRE CONTACT.
- ⚠️ CONTACTS PLATED GOLD PLATED FOR LENGTH OF .150 MIN FROM MATING END, GOLD FLASH IN MATED AREA. .000100—.000200 BRIGHT TIN OR BRIGHT IN TIN-LEAD IN WIRE TERMINATION AREA. .000030 NICKEL UNDERPLATE ON ENTIRE CONTACT.
- ⚠️ RAISED CAVITY IDENTIFICATION AND AMP TRADEMARK.
- ⚠️ CONTACTS GOLD PLATED FOR A LENGTH OF .150 MIN FROM MATING END, .000030 MIN GOLD IN MATED AREA, .000100—.000200 MATTE TIN IN WIRE TERMINATION AREA, ALL OVER .000050 MIN NICKEL UNDERPLATE ON ENTIRE CONTACT.  
OR  
CONTACTS GOLD PLATED FOR A LENGTH OF .150 MIN FROM MATING END, GOLD FLASH OVER PALLADIUM-NICKEL, .000030 MIN TOTAL IN MATED AREA, .000100—.000200 MATTE TIN IN WIRE TERMINATION AREA, ALL OVER .000050 MIN NICKEL UNDERPLATE ON ENTIRE CONTACT.

OBSOLETE	⚠️	3	#20-22	747515-8
	⚠️	2	#22-26	747515-7
OBSOLETE	⚠️	3	#20-22	747515-6
OBSOLETE	⚠️	2	#22-26	747515-5
OBSOLETE	⚠️	1	#26-30	747515-4
OBSOLETE	⚠️	3	#20-22	747515-3
OBSOLETE	⚠️	2	#22-26	747515-2
OBSOLETE	⚠️	1	#26-30	747515-1
	CONTACT FINISH	⚠️	WIRE RANGE	PART NUMBER

THIS DRAWING IS A CONTROLLED DOCUMENT.		DWN L. VARELA - DOCK5 11-16-04		
DIMENSIONS: INCHES		CHK J. GERACE 11-16-04		
TOLERANCES UNLESS OTHERWISE SPECIFIED:		APVD M. WALMSLEY 11-16-04	NAME	
0 PLC ± -		PRODUCT SPEC		KIT, PLUG, SHIELDING HARDWARE, SIZE 1, 9 POSN, HDE-20, AMPLIMITE
1 PLC ± -		108-40011 & 108-40030		
2 PLC ± -		APPLICATION SPEC		SIZE
3 PLC ± .005		114-40002		CAGE CODE
4 PLC ± -		WEIGHT -		DRAWING NO
ANGLES ± 0° 30'		CUSTOMER DRAWING		RESTRICTED TO
MATERIAL SEE CALL-OUTS		FINISH SEE TABLE		SCALE
		A2 00779 C=747515		SHEET
		SCALE 2:1		1 of 1
		REV M1		

单击下面可查看定价，库存，交付和生命周期等信息

[>>TE Connectivity\(泰科\)](#)