



**i NOTE**

All numerical values are in metric units [with U.S. customary units in brackets]. Dimensions are in millimeters [and inches]. Unless otherwise specified, dimensions have a tolerance of  $\pm 0.13$  [ $\pm .005$ ] and angles have a tolerance of  $\pm 2^\circ$ . Figures and illustrations are for identification only and are not drawn to scale.

**1. INTRODUCTION**

This specification covers the requirements for application of AMPMODU 50/50 Grid SMT (Surface Mount Technology) printed circuit (pc) board connectors, Through Hole (TH) PC board connectors and IDC (Insulation Displacement Contact) cable connectors. The connectors have contacts with in- row spacing on 1.27 [.050] centers and row- to- row spacing on 1.27 [.050] centers. They are available in 10- position increments from 10 through 100; the vertical SMT connectors are also available with 16 positions.

The SMT connectors are available as receptacles, and as vertical or right- angle pin header assemblies. They feature solderable hold- downs that help to stabilize the connector before and after soldering. There are unpolarized connectors with two large or two medium hold- downs, and there are polarized connectors containing a large hold- down at the end where the stack height marking is located and a small hold- down at the opposite end. All connectors can be placed on the pc board by hand.

The TH connectors are available as receptacles, and as vertical pin header assemblies. They feature solderable hold- downs that help to stabilize the connector before and after soldering. All connectors can be placed on the pc board by hand.

The IDC connectors are available as receptacle assemblies. Each consists of a housing with insulation displacement contacts and two unassembled covers. These connectors are designed to terminate solid or 7- strand, 30 to 28 AWG ribbon cable with an insulation diameter range of 0.74 to 0.91 [.029 to .036]. They are terminated using manually operated tools.

When corresponding with TE Connectivity (TE) Representatives, use the terminology provided in this specification to facilitate your inquiry for information. Basic terms and features of the connectors are provided in Figures 1, 2 and 3.

*SMT Connectors*

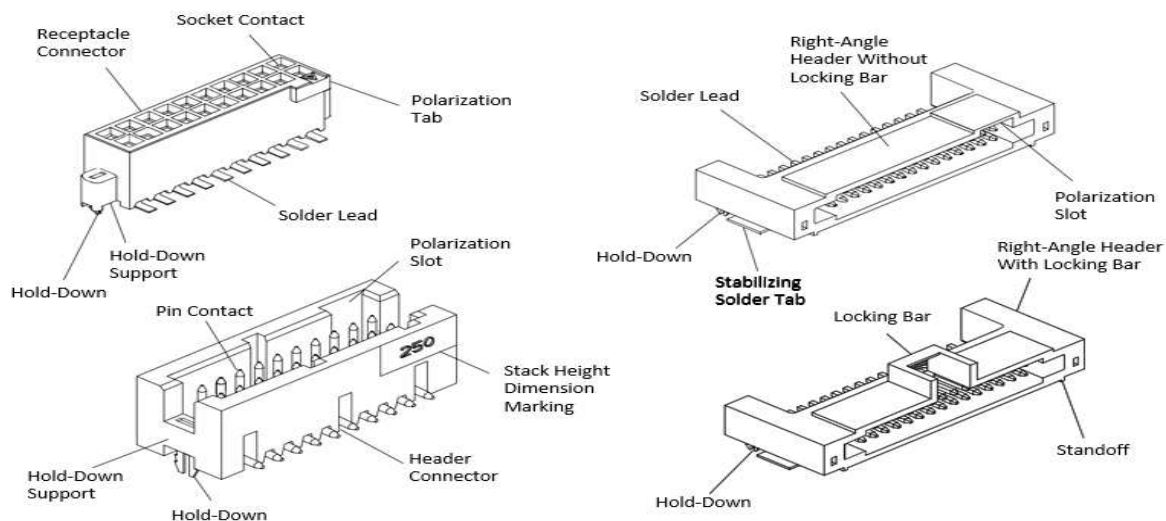

*Figure 1*

IDC Connectors

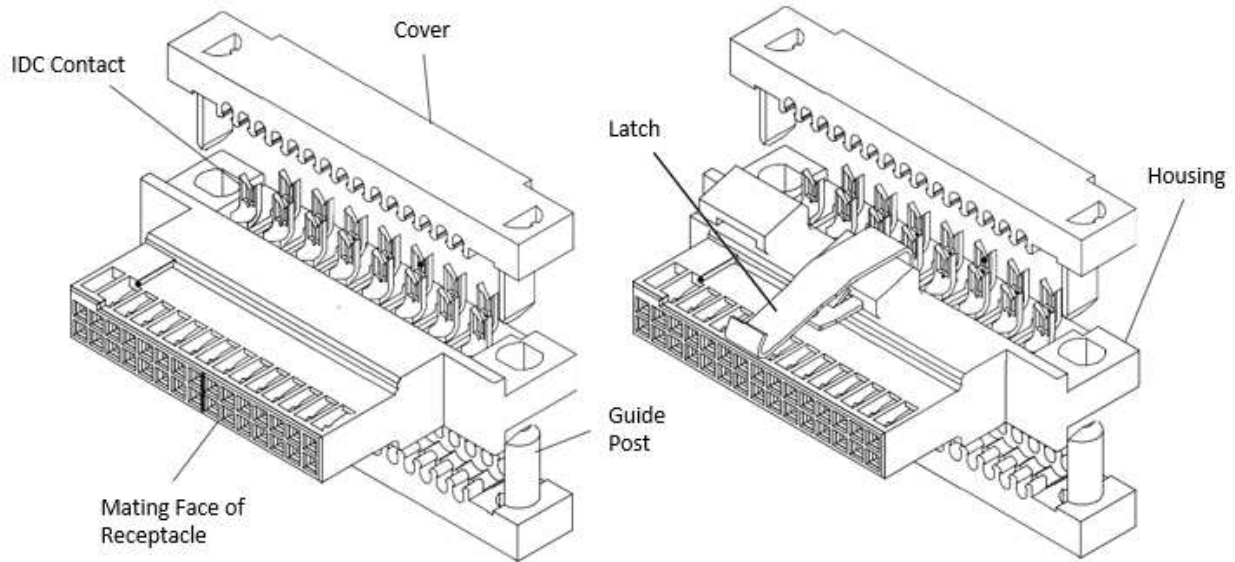

Figure 2

Through Hole Connectors

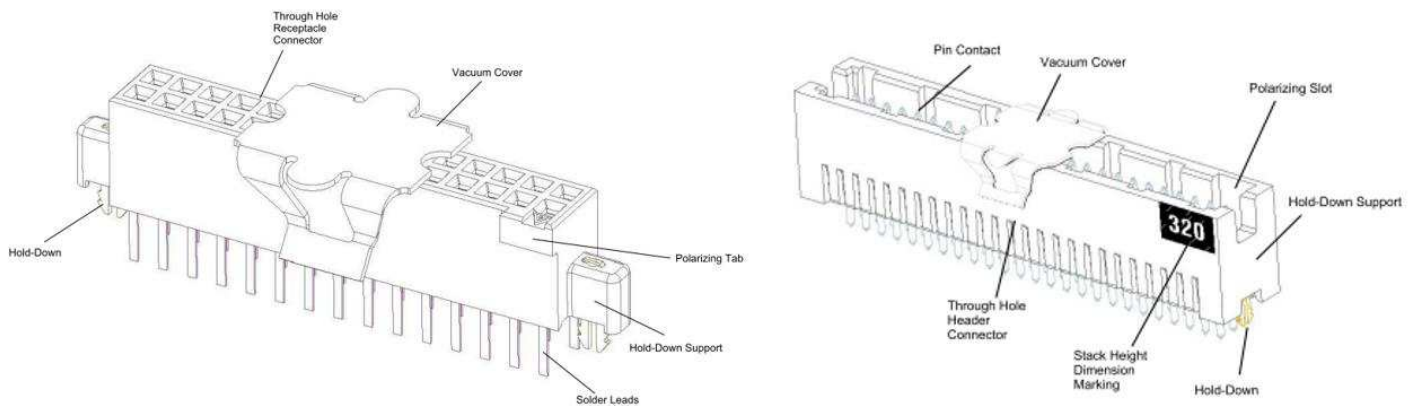

Figure 3



## 2. REFERENCE MATERIAL

### 2.1. Revision Summary

This paragraph is reserved for a revision summary of changes covering the most recent additions and changes made to this specification which include the following:

- Added Through Hole Products
- Added Plated Through Hole callouts

### 2.2. Customer Assistance

Reference Part Number 104652 and Product Code 5375 are representative numbers of AMPMODU 50/50 Grid Connectors. Use of these numbers will identify the product line and expedite your inquiries through a service network established to help you obtain product and tooling information. Such information can be obtained through a local TE Representative or, after purchase, by calling the Tooling Assistance Center or Product Information number at the bottom of page 1.

### 2.3. Drawings

Customer Drawings for specific products are available from the service network. The information contained in Customer Drawings takes priority if there is a conflict with this specification or with any other technical documentation supplied by TE.

### 2.4. Manuals

Manual 402- 40 is available from the service network. This manual provides information on various flux types and characteristics along with the commercial designation and flux removal procedures. A checklist is included in the manual as a guide for information on soldering problems.

### 2.5. Specifications

#### A. Product Specifications

Product Specifications 108- 1332 and 108- 1443 cover test and performance requirements for the SMT and IDC connectors respectively.

#### B. Test Specifications

Test Specification 109- 11 covers suggested test and evaluation methods.

#### C. Workmanship Specification

Workmanship Specification 101- 21 provides requirements and evaluation of solder fillets for surface mounted connectors.

#### D. Commercial Specification

Commercial specification J- STD- 001 provides solder joint requirements.



## 2.6. Instruction Material

The following Instruction Sheets (408) are available for tooling application and repair information for IDC Connectors.

408- 9817 - Applicator Frame Assembly

408- 9909 - Cover Closing Tool

## 3. REQUIREMENTS

### 3.1. Material

The housings for all the connectors are made of glass- filled thermoplastic and the contacts of copper alloy, or phosphor bronze nickel underplated with gold plated contact mating ends. Surface- mount and Through hole solder leads are tin-lead or Tin plated.

### 3.2. Storage

Connectors are packaged and shipped in antistatic tube containers. To prevent damage to the housings and contacts, the connectors should remain in the container until ready for installation. Also, to prevent possible storage contamination and insure maximum solderability for SMT solder leads, the connectors should be used on a first in, first out basis.

### 3.3. Circuit Identification

The number 1 molded on the mating face of the housing provides circuit identification, and the number in the rectangular block molded on the side of the vertical connector housing provides the stacking dimension (in thousandths of an inch) between pc boards when two connectors are fully mated. See Figure 1.

### 3.4. Printed Circuit Boards for SMT Connectors

#### A. Tolerance

At the time of connector placement, the coplanarity of the pad pattern must be held to 0.05 [.002] maximum. We recommend a solder mask to minimize solder bridging between pads. The mask must not exceed the height of the pad by more than 0.05 [.002].



Since the connector housings may rest on top of the solder mask, an excessively high mask will allow too much space between the solder lead and pad for a good solder joint. A solder joint under these conditions would be weak and would not provide long term performance for the connector.

#### B. Material

The pc board material shall be glass epoxy (FR- 4 or G- 10) and should be 1.58 + 0.18 [.062 + .007] thick to ensure proper performance of the connector hold- downs. Consult TE Engineering for suitability of other materials, or other board thicknesses. A solder mask is recommended when soldering SMT connectors.

Those most suitable are Liquid Photo Imageable and Dry Film.

**C. PC Board Layout**

Recommended pc board patterns are provided in Figures 3 through 6. See Figure 3 for vertical receptacles, Figure 4 for vertical headers, Figure 5 for right- angle headers, and Figure 6 and 7 for typical pc board plated through hole configurations.

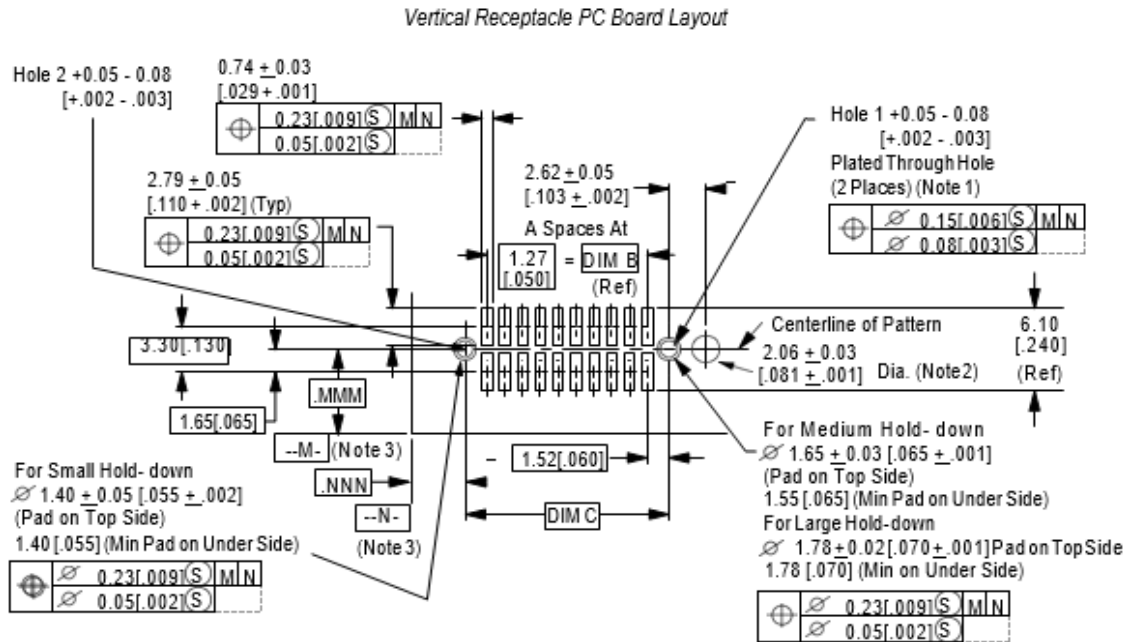

NUMBER OF POSITIONS	NUMBER OF SPACES (A)	DIMENSIONS		HOLD-DOWNS		
		B	C	LARGE	MEDIUM	SMALL
10	4	5.08 [0.200]	8.13 [0.320]	1.32 [0.052] Holes 1 and 2 in Unpolarized Connectors with Large Hold-downs	1.19 [0.047] Holes 1 and 2 in Unpolarized Connectors with Medium Hold-downs	0.94 [0.037] Hole 2 only in Polarized Connectors (Other End has Large Hold-down)
16	7	8.89 [0.350]	11.94 [0.470]			
20	9	11.43 [0.450]	14.48 [0.570]			
30	14	17.78 [0.700]	20.83 [0.820]			
40	19	24.13 [0.950]	27.18 [1.070]			
50	24	30.48 [1.200]	33.53 [1.320]			
60	29	36.83 [1.450]	39.88 [1.570]			
70	34	43.18 [1.700]	46.23 [1.820]			
80	39	49.53 [1.950]	52.58 [2.070]			
90	44	55.88 [2.200]	58.93 [2.320]			
100	49	62.23 [2.450]	65.28 [2.570]			

- NOTES:**
- Hold-down hole. Finish to be tin/lead over 0.03 [0.001] minimum copper.  
For large hold-down use  $1.510 \pm 0.030$  [ $0.0595 \pm .0010$ ] drilled hole (No. 53 drill bit).  
For medium hold-down use  $1.320 \pm 0.030$  [ $0.0520 \pm .0010$ ] drilled hole (No. 55 drill bit).  
For small hold-down use  $1.070 \pm 0.030$  [ $0.0810 \pm .0010$ ] drilled hole (No. 58 drill bit).
  - Optional polarization hole  $2.060 \pm 0.030$  [ $0.0810 \pm .0010$ ] drilled hole (No. 46 drill bit). This feature can be used to help ensure proper orientation of the connector on the board. It will require the use of a polarized hand loading tool (see Section 5).
  - Customer established datum.

Figure 3

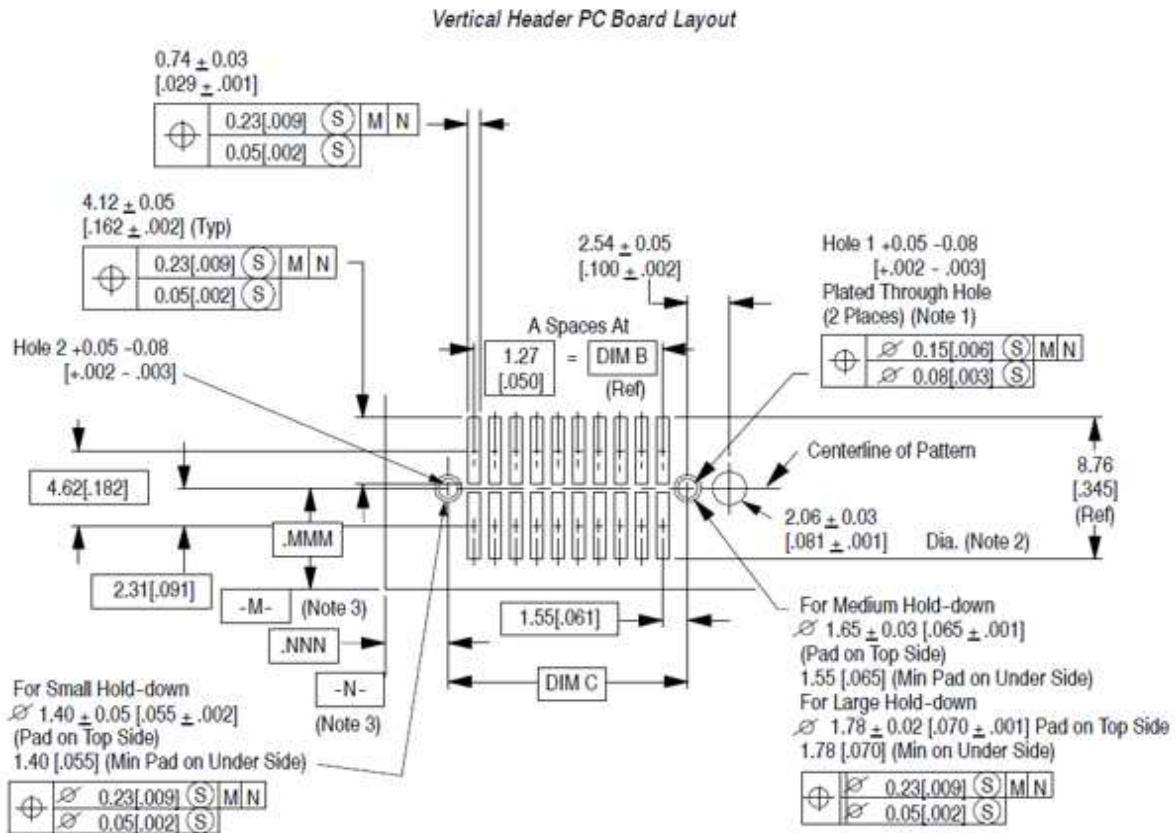

NUMBER OF POSITIONS	NUMBER OF SPACES (A)	DIMENSIONS		HOLD-DOWNS		
		B	C	LARGE	MEDIUM	SMALL
10	4	5.08 [0.200]	8.13 [0.320]	1.32 [.052] Holes 1 and 2 in Unpolarized Connectors with Large Hold-downs	1.19 [.047] Holes 1 and 2 in Unpolarized Connectors with Medium Hold-downs	0.94 [.037] Hole 2 only in Polarized Connectors (Other End has Large Hold-down)
16	7	8.89 [0.350]	11.94 [0.470]			
20	9	11.43 [0.450]	14.48 [0.570]			
30	14	17.78 [0.700]	20.83 [0.820]			
40	19	24.13 [0.950]	27.18 [1.070]			
50	24	30.48 [1.200]	33.53 [1.320]			
60	29	36.83 [1.450]	39.88 [1.570]			
70	34	43.18 [1.700]	46.23 [1.820]			
80	39	49.53 [1.950]	52.58 [2.070]			
90	44	55.88 [2.200]	58.93 [2.320]			
100	49	62.23 [2.450]	65.28 [2.570]			

- NOTES:
- Hold-down hole. Finish to be tin/lead over 0.03 [.001] minimum copper.  
For large hold-down use 1.510 ± 0.030 [.0595 ± .0010] drilled hole (No. 53 drill bit).  
For medium hold-down use 1.320 ± 0.030 [.0520 ± .0010] drilled hole (No. 55 drill bit).  
For small hold-down use 1.070 ± 0.030 [.0810 ± .0010] drilled hole (No. 58 drill bit).
  - Optional polarization hole 2.060 ± 0.030 [.0810 ± .0010] drilled hole (No. 46 drill bit). This feature can be used to help ensure proper orientation of the connector on the board. It will require the use of a polarized hand loading tool (see Section 5).
  - Customer established datum.

Figure 4



Right - Angle Header PC Board Layout

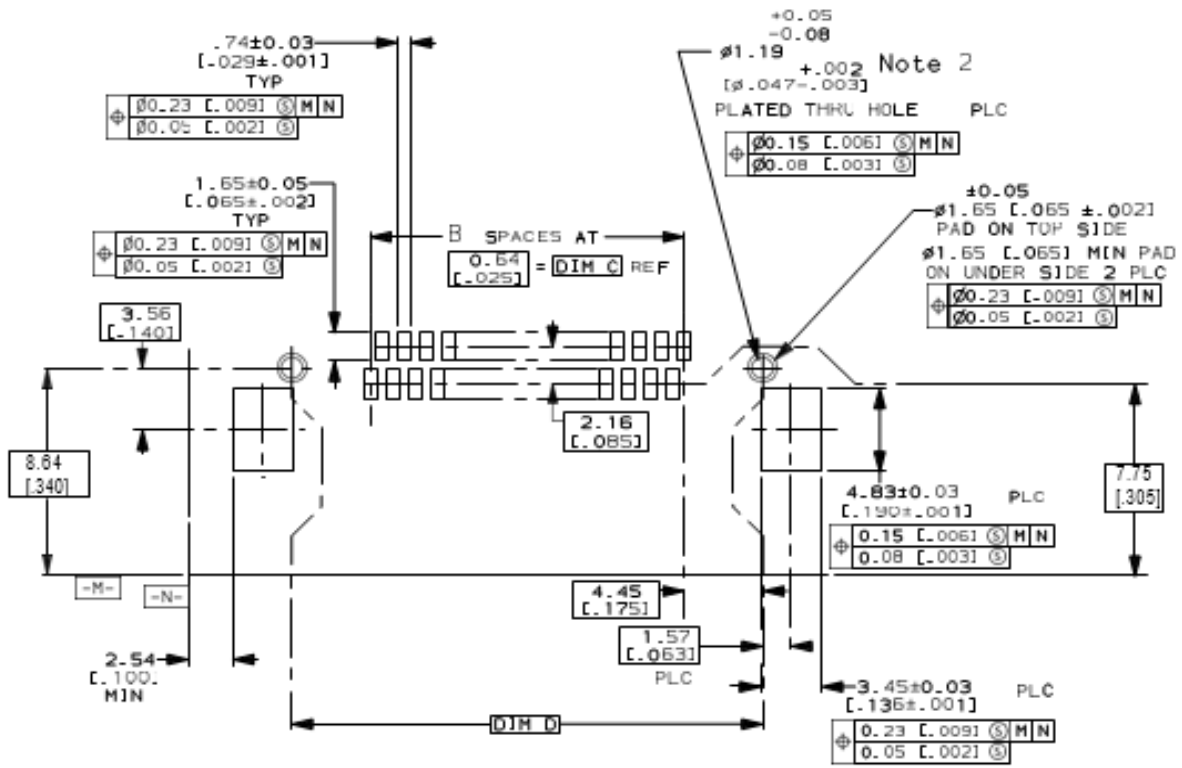

Recommended Board Layout

NUMBER OF POSITIONS	NUMBER OF SPACES (B)	DIMENSIONS	
		C	D
10	9	5.72 [0.225]	13.97 [0.550]
20	19	12.07 [0.475]	20.32 [0.800]
30	29	18.42 [0.725]	26.67 [1.050]
40	39	24.77 [0.975]	33.02 [1.300]
50	49	31.12 [1.225]	39.37 [1.550]
60	59	37.47 [1.475]	45.72 [1.800]
70	69	43.82 [1.725]	52.07 [2.050]
80	79	50.17 [1.975]	58.42 [2.300]
90	89	56.52 [2.225]	64.77 [2.550]
100	99	62.87 [2.475]	71.12 [2.800]

NOTES: 2. Hold-down hole. Use 1.32±0.03 [0.052±0.001] drilled hole (No. 55 drill bit). Finish to be tin/lead over 0.03 [0.001] minimum copper.

Figure 5

*Vertical Through Hole PCB Layout*

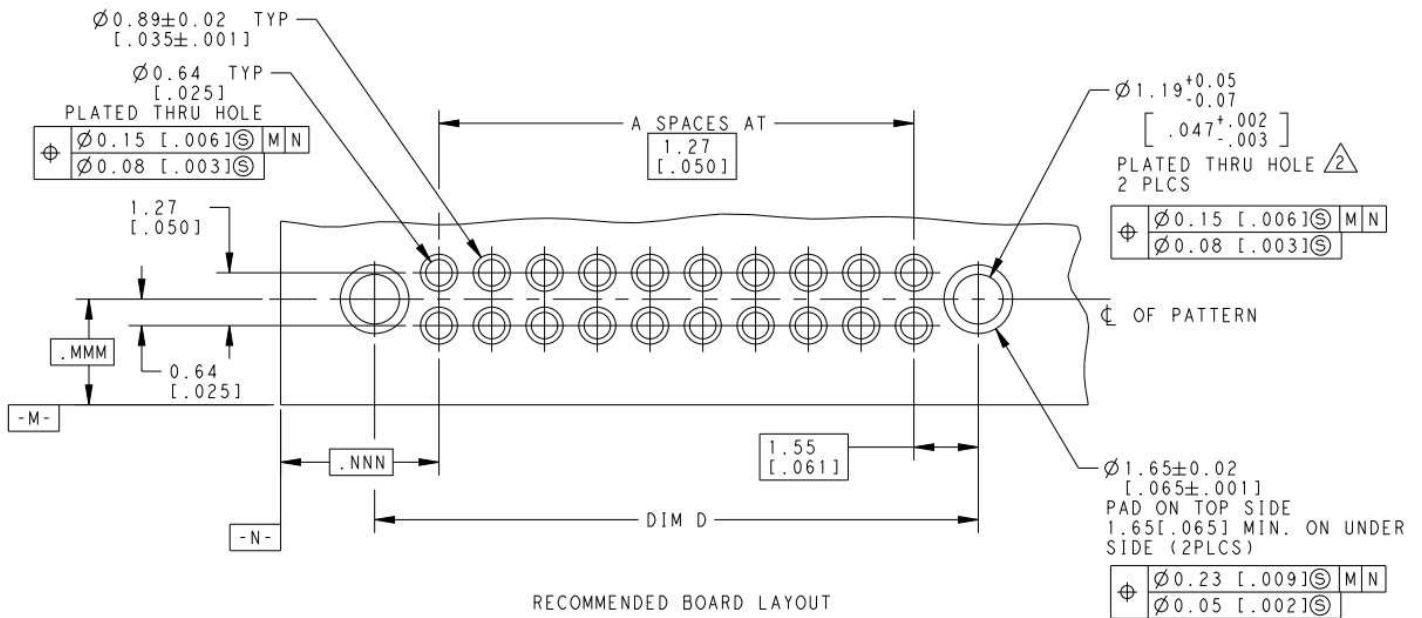

NUMBER OF POSITIONS	NUMBER OF SPACES (A)	"D" DIMENSION	
		MM	INCH
10	4	8.18	0.322
20	9	14.53	0.572
30	14	20.88	0.822
40	19	27.23	1.072
50	24	33.58	1.322
60	29	39.93	1.572
70	34	46.28	1.822
80	39	52.63	2.072
90	44	58.98	2.322
100	49	65.33	2.572

Figure 6



### 3.5. Contact Hole Configuration for Through Hole Connectors

The contact holes in the pc boards must be drilled and plated through to specific dimensions. See Figure 4.

#### Hold Down Hole

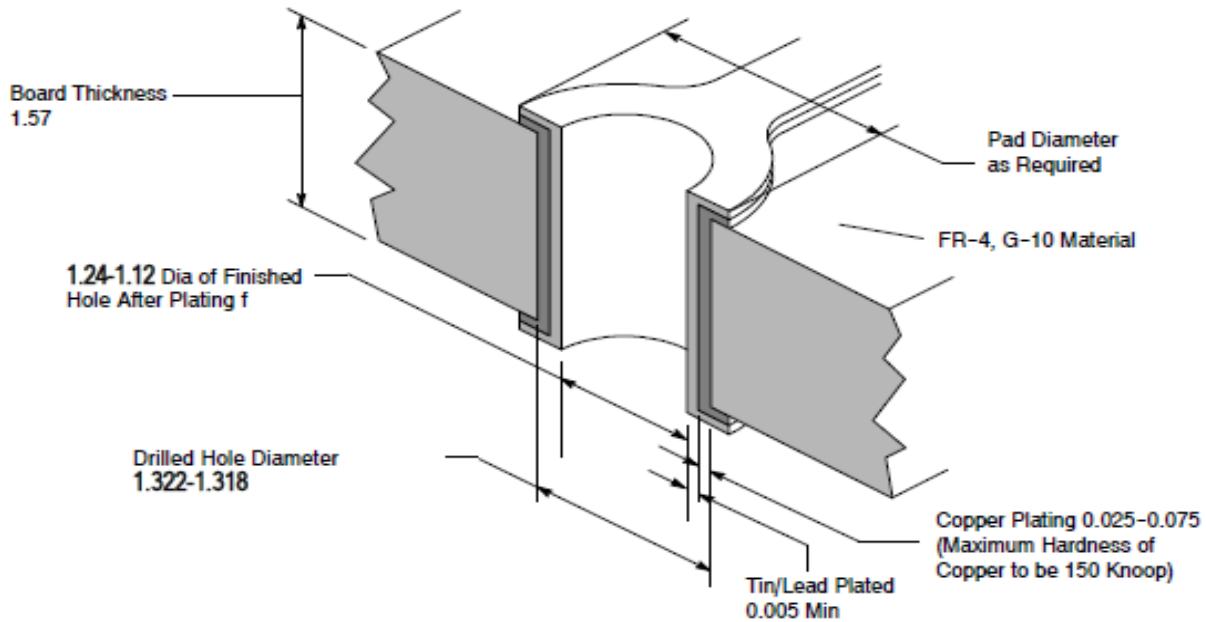

#### Plated Through Holes

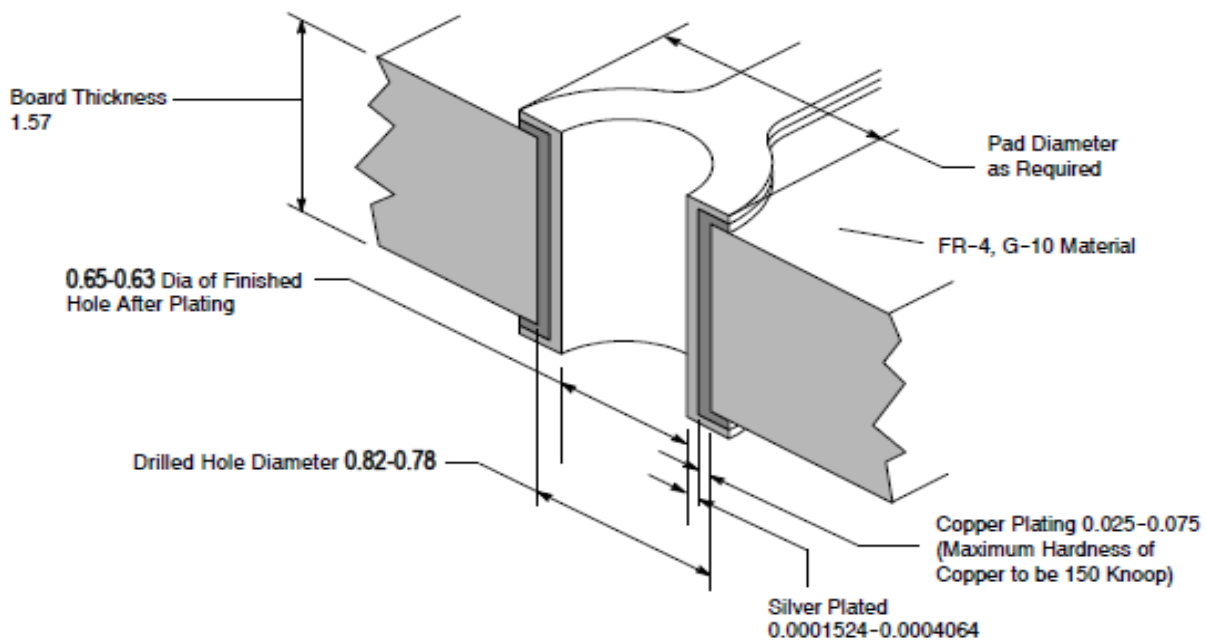

Figure 7

### 3.6. Spacing

#### A. On PC Board Spacing

Connectors can be placed in close proximity to each other on the pc board. The dimensions provided do not include space needed for other pc board components. Check spacing requirements for other components before making your placement layout on the pc board. See Figure 7.

**NOTE**



The use of more than one vertical connector pair to interconnect two pc boards is not recommended due to tolerance build-up.

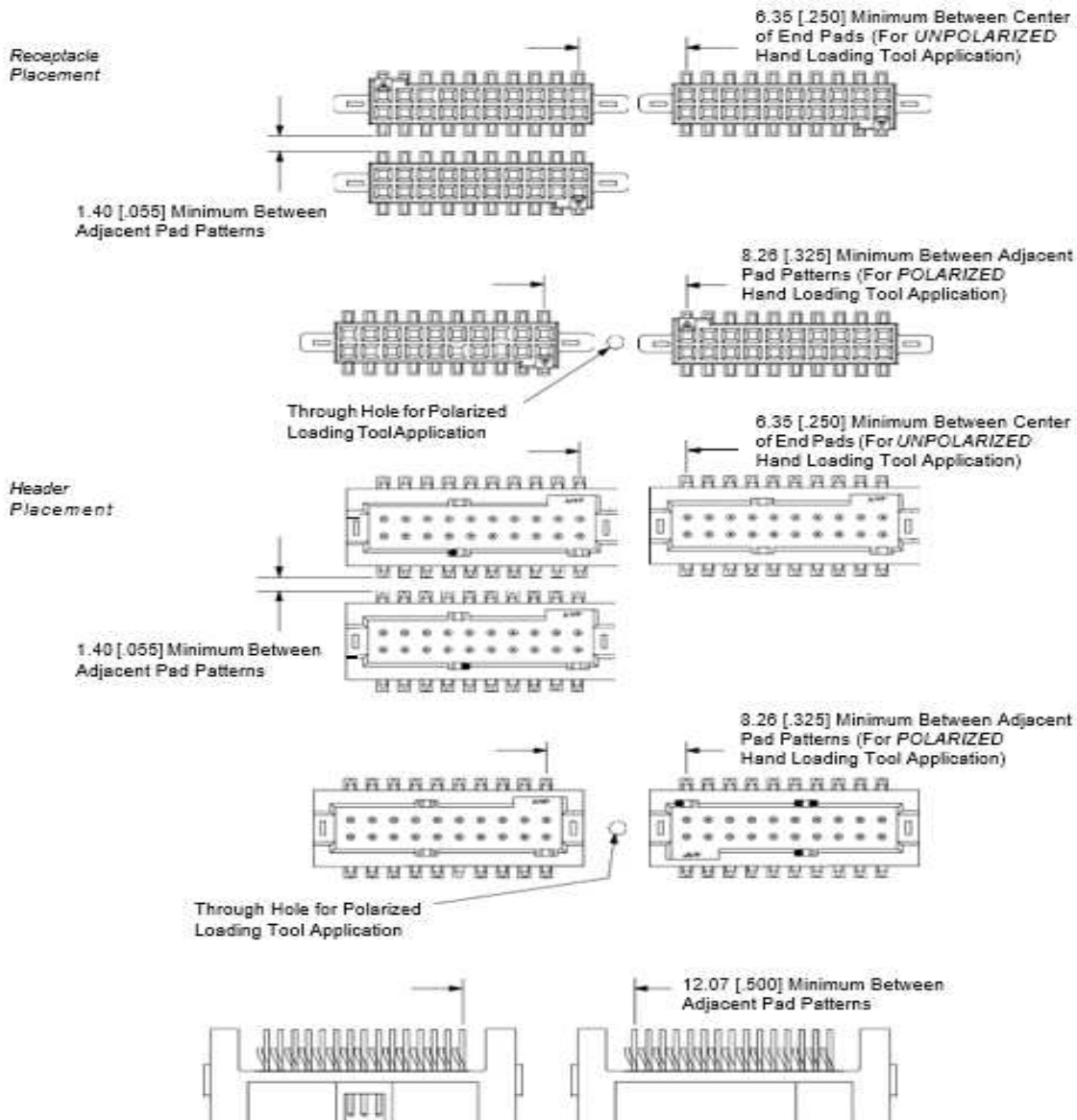
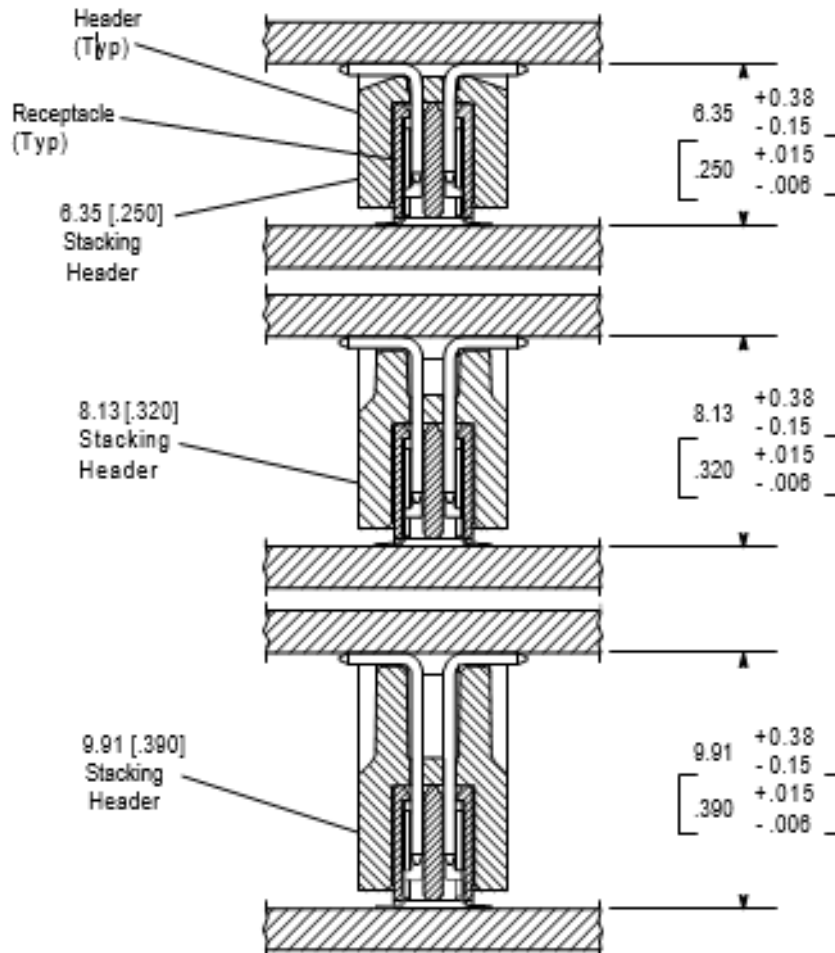

Figure 8

## B. BETWEENPCBOARDSPACING

Board- to- board stacking dimensions for the three vertical header configurations are provided in Figure 9.



**NOTE:** Connector housings must be bottomed on each other to ensure full contact engagement. When fully mated, dimension between boards will be within the range shown.

Figure 9

### 3.7. Polarization and Position Locator

The vertical headers have a polarizing slot and the vertical receptacles have a polarizing tab to ensure proper orientation of mating connectors. These features provide a reference location of the number one contact position. See Figure 1.

### 3.8. Stack Height Indicator

Each vertical header has a dimensional marking on the shroud of 250, 320, or 390 to indicate the nominal spacing in thousandths of an inch between parallel stacked pc boards. See Figure 1.



### 3.9. Mechanical Supports

#### A. Integral Hold- Downs

Hold- downs are an integral part of each connector. They go into plated through holes in the pc board to help stabilize the connectors prior to and during soldering, and they provide some strain relief after soldering. They are soldered into the plated through holes in the pc board during the soldering of the solder leads. The hold- downs are designed for 1.58 [.062] pc boards

#### B. Packaging Hardware

The system should be designed with support for the pc boards to minimize stress on the solder leads of surface-mounted connectors.



*The vertical header and receptacle inherently function as a standoff; however, they must not be used as the only standoff support between two pc boards.*

### 3.9. Processing

The pc board pads must be solderable in accordance with Test Specification 109- 11- 1.

#### A. Typical Solder Paste Characteristics

1. Alloy type shall be either 63 Sn/37 Pb or 60 Sn/40 Pb.
2. Flux shall be RMA type.
3. Solids by weight shall be 85% minimum.
4. Mesh designation - 200 to +325 (74 to 44 square micron openings, respectively).
5. Minimum viscosity of screen print shall be 5 x 10% cp (centipoise).
6. Minimum viscosity of stencil print shall be 7.5 x 10% cp (centipoise).

#### B. Solder Volume

Solder volume for each component shall be:

Receptacle .....	0.17 mm <sup>3</sup> [.0000106 in. <sup>3</sup> ] per contact
Vertical Header.....	0.71 mm <sup>3</sup> [.0000432 in. <sup>3</sup> ] per contact
Vertical Hold- down .....	1.34 mm <sup>3</sup> [.0000819 in. <sup>3</sup> ] per vertical header hold- down
Right- Angle Header .....	0.22 mm <sup>3</sup> [.0000134 in. <sup>3</sup> ] per contact
Right- Angle Hold- Down Barb....	1.50 mm <sup>3</sup> [.0000914 in. <sup>3</sup> ] per right- angle header hold- down
Right- Angle Hold- Down Pad .....	2.41 mm <sup>3</sup> [.0001470 in. <sup>3</sup> ] per right- angle header hold- down



Solder volume may vary depending on solder paste composition.

#### C. STENCIL

Stencil aperture will be determined by the thickness of the stencil being used. Generally, the thinner stencils will have a larger aperture to maintain a given volume of solder paste. Solder deposition should be within the pad area of the contact solder tines. Typical aperture openings are provided in Figures 10, 11, and 12.



All traces must be covered by solder mask in the solder deposit area. Exposed traces could cause bridging and create a short, or wick solder away from the solder leads, producing a weak solder joint.



If a hold-down aperture is required other than that specified, the design must ensure that the connector housing will not sit on the solder deposit.



The recommended aperture width is 0.64 [0.025] for the vertical receptacles and right - angle headers, and 0.69 [0.027] for the vertical headers. It may be wider; however, care must be given to ensure against solder bridging during processing.

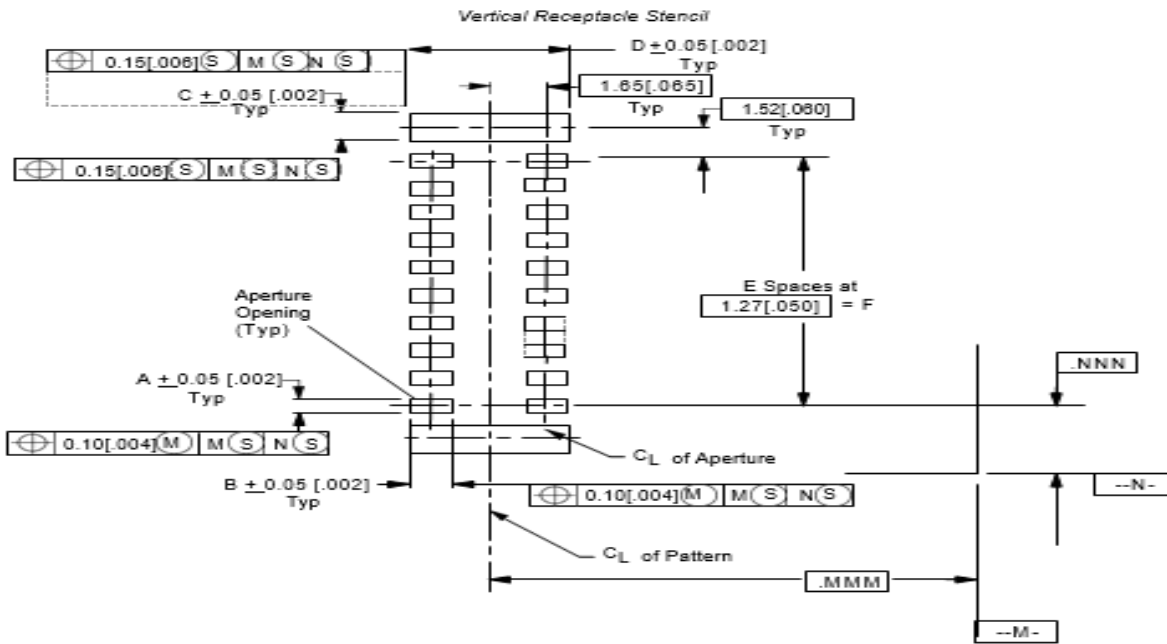

NOMINAL PAD SIZE	STENCIL THICKNESS	PAD APERTURE DIMENSION		HOLD-DOWN APERTURE DIMENSION	
		A	B	C	D
0.74 X 2.79 [.029 X .110]	0.20 [.008]	0.64 [.025]	1.35 [.053]	2.01 [.079]	3.30 [.130]
	0.23 [.009]	0.64 [.025]	1.19 [.047]	1.78 [.070]	3.30 [.130]
	0.25 [.010]	0.64 [.025]	1.09 [.043]	2.01 [.079]	3.30 [.130]
NO. OF POSN (10 - 50)	E (Spaces)	F (Center to Center)	NO. OF POSN 60 - 100	E (Spaces)	F (Center to Center)
	10	4		5.08 [0.200]	29
18	7	8.89 [0.350]	70	34	43.18 [1.700]
20	9	11.43 [0.450]	80	39	49.53 [1.950]
30	14	17.78 [0.700]	90	44	55.88 [2.200]
40	19	24.13 [0.950]	100	49	62.23 [2.450]
50	24	30.48 [1.200]	--	--	--

Figure 10

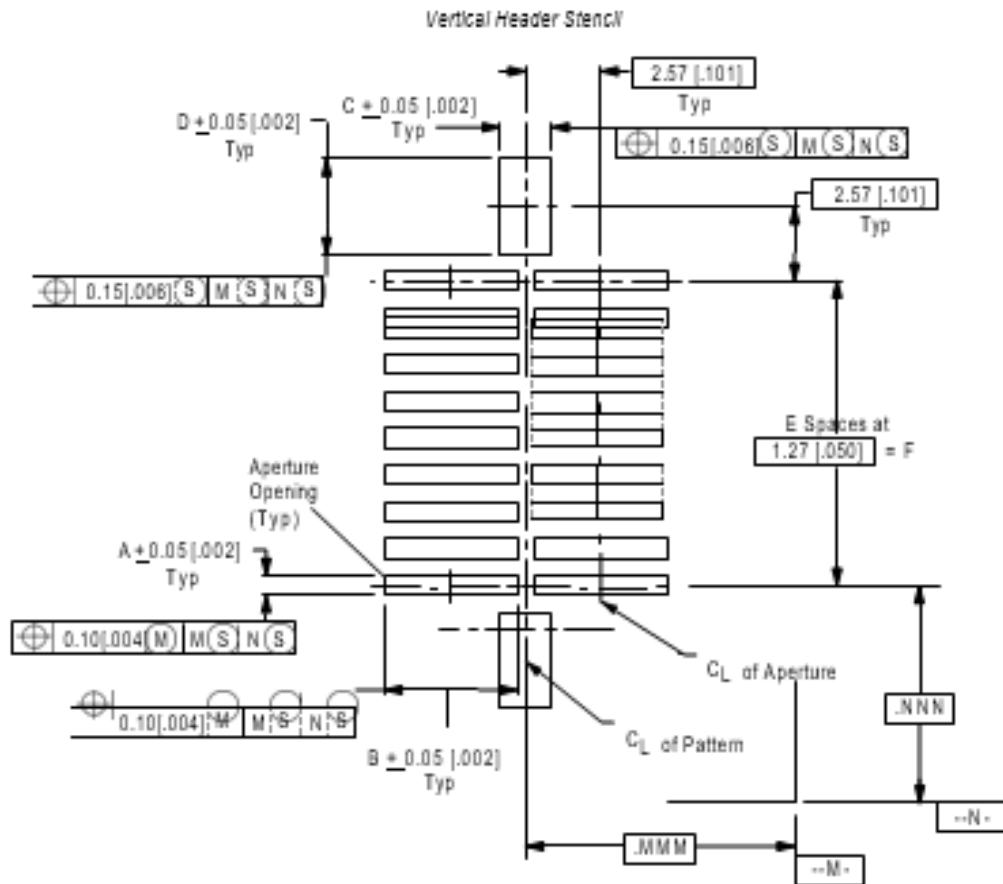

NOMINAL PAD SIZE	STENCIL THICKNESS	PAD APERTURE DIMENSION		HOLD-DOWN APERTURE DIMENSION	
		A	B	C	D
0.74 X 4.11 [.029 X .162]	0.20 [.008]	0.74 [.029]	4.72 [.188]	1.40 [.055]	4.72 [.188]
	0.23 [.009]	0.69 [.027]	4.52 [.178]	1.27 [.050]	4.62 [.182]
	0.25 [.010]	0.69 [.027]	4.06 [.160]	1.27 [.050]	4.17 [.164]

NO. OF POSN (10 - 50)	E	F	NO. OF POSN 50 - 100	E	F
	{spaces}	{Center to Center}		{spaces}	{Center to Center}
10	4	5.08 [0.200]	60	29	36.83 [1.450]
18	7	8.89 [0.350]	70	34	43.18 [1.700]
20	9	11.43 [0.450]	80	39	49.53 [1.950]
30	14	17.78 [0.700]	90	44	55.88 [2.200]
40	19	24.13 [0.950]	100	49	62.23 [2.450]
50	24	30.48 [1.200]	--	--	--

Figure 11



Right - Angle Header Assembly Stencil

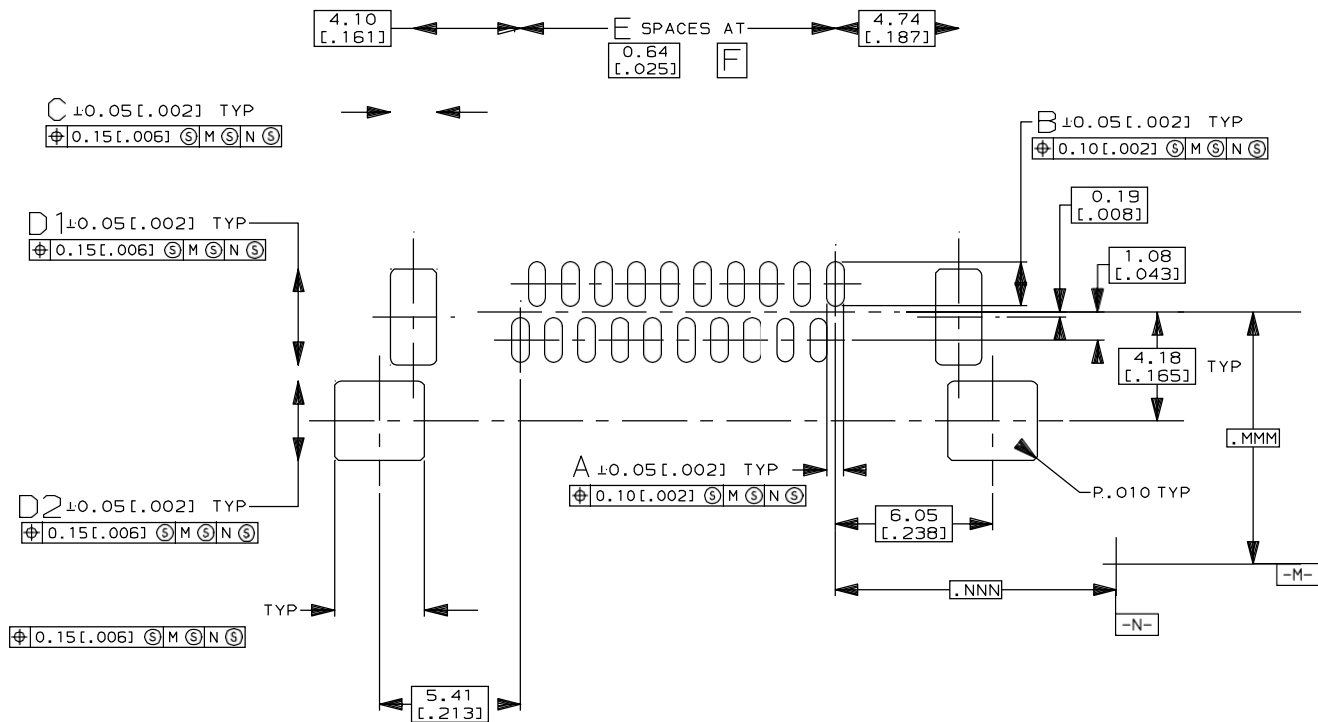

NOMINAL PAD SIZE	STENCIL THICKNESS	PAD APERTURE DIMENSION		HOLD DOWN APERTURE DIMENSION		
		A	B	C	D1	D2
0.74 x 2.79 [.029 X .110]	0.20 [.008]	0.64 [.025]	1.83 [.072]	1.78 [.070]	4.14 [.163]	3.43 [.135]
	0.23 [.009]	0.64 [.025]	1.65 [.065]	1.78 [.070]	3.68 [.145]	3.05 [.120]
	0.25 [.010]	0.64 [.025]	1.50 [.059]	1.78 [.070]	3.33 [.131]	2.74 [.108]

NO. OF POSN (10-50)	E (SPACES)	F (CENTER-TO-CENTER)	NO. OF POSN (60-100)	E (SPACES)	F (CENTER-TO-CENTER)
	10	9		5.76 [.225]	60
20	19	2.16 [.475]	70	69	44.16 [1.725]
30	29	18.56 [.725]	80	79	50.55 [1.975]
40	39	24.96 [.975]	90	89	56.96 [2.225]
50	49	31.36 [1.225]	100	99	63.36 [2.475]

Figure 12

#### D. SOLDER SCREEN

Generally, we do not recommend screen application of solder paste because of the limited volume of paste that can be deposited. If a screen application is required, we recommend removal of all screen from the solder tine and hold-down pad areas. Consult your supplier for compatibility of screen and paste, and for application techniques.

#### E. SOLDER MASK

Solder mask is recommended between all pads. If a trace is run between adjacent pads on the solder side of the pc board, a solder mask must be applied over the trace to prevent bridging and wicking of solder away from the contact solder tines. Additionally, there should be solder mask covering any traces in the area of the hold-down solder deposit. Liquid Photo Imageable or Dry Film solder masks are recommended.

#### F. CONNECTOR PLACEMENT

Connectors can be placed on the pc board by hand. When doing so, grip the connector at the ends of the housing without touching the contact to prevent contamination and deformation of the solder tines. Vertical connectors can be placed on the pc board with a hand loading tool. When using the tool, the connectors should be emptied from the shipping tube into a feeder device and picked up with the tool as described in the instructions packaged with the tool.

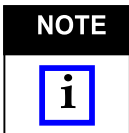

*Optimally, the connector solder tines should be aligned on the pc board pads. However, misregistration is permissible for certain performance classifications as specified in J-STD-001. See Figure 13.*

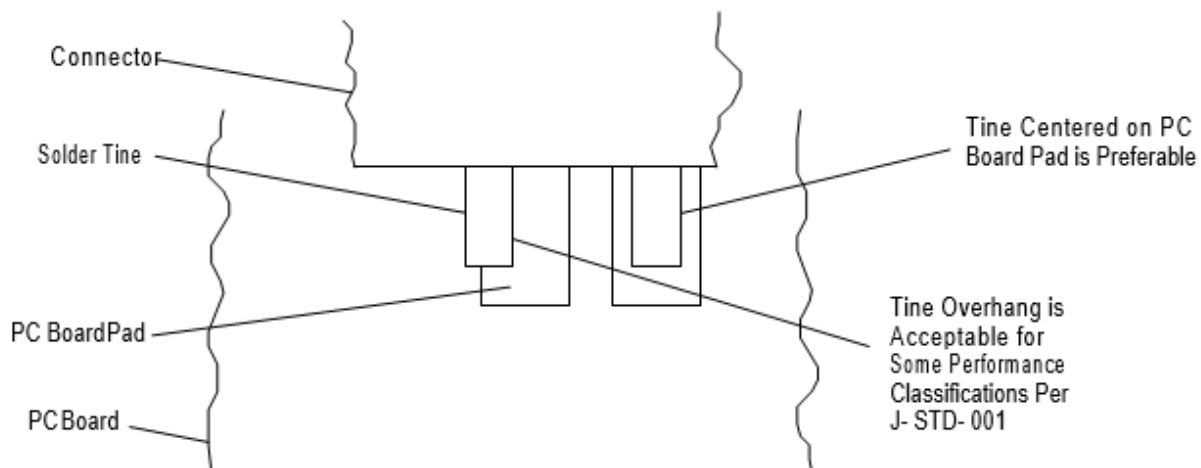

Figure 13





**G. SOLDER**

1. Parameters

The connectors will withstand temperatures of 260\_C [500\_F] for a maximum of three minutes. Higher temperatures can be withstood for short periods of time as indicated in Figure 14 for the infrared (IR) reflow. Refer to the recommendations provided in Figure 14 for typical reflow parameters. Due to the many variables involved with the reflow process (i.e., component density, orientation, etc.), we recommend that the user conduct trial runs under actual manufacturing conditions to ensure product and process compatibility.

Preheat 350_C [662_F]	ZONE 1	ZONE 2	ZONE 3
TOP HEATER	285_ [545_]	265_ [509_]	310_ [590_]
BOTTOM HEATER	285_ [545_]	265_ [509_]	310_ [590_]

Figure 14

2. Process

We recommend that connectors be soldered using vapor phase (VPR), double sided non- focused infrared (IR), or equivalent soldering technique. We have had success using Vitronics IR (Model SMD 718) equipment.

Vitronics is a trademark.

**H. CLEANING**

Removal of fluxes, residues, and activators is necessary. Consult with the supplier of the solder paste and flux for recommended cleaning solvents. The following is a listing of common cleaning solvents that will not affect the receptacle and header connectors. The connectors will be unaffected by any of these solvents for five minutes at 105\_C [221\_F]. See Figure 15.

CLEANER		TIME (Minutes)	TEMPERATURES (Maximum)	
NAME	TYPE		CELSIUS	FAHRENHEIT
Alpha 2110	Aqueous	1	132	270
Bioact EC- 7	Solvent	5	100	212
Butyl Carbitol	Solvent	1	Room Ambient	
Isopropyl Alcohol	Solvent	5	100	212
Kester 5778	Aqueous	5	100	212
Kester 5779	Aqueous	5	100	212
Loncoterge 520	Aqueous	5	100	212
Loncoterge 530	Aqueous	5	100	212
Terpene Solvent	Solvent	5	100	212

Figure 15

Alpha, Bioact, Carbitol, Kester, and Loncoterge are trademarks of their respective owners.



**DANGER**



Consideration must be given to toxicity and other safety requirements recommended by the solvent manufacturer. Trichloroethylene and Methylene Chloride can be used with no harmful affect to the connectors; however, TE does not recommend them because of the harmful occupational and environmental affects. Both are carcinogenic (cancer- causing) and Trichloroethylene is harmful to the earth's ozone layer.

**NOTE**



If you have a particular solvent that is not listed, contact TE Engineering by calling the Tooling Assistance Center toll-free number on page 1.

### I. CHECKING INSTALLED CONNECTOR

All solder joints should conform to those specified in Workmanship Specification 101- 21. The housing must seat on the pc board to within the tolerance provided in Figure 16.

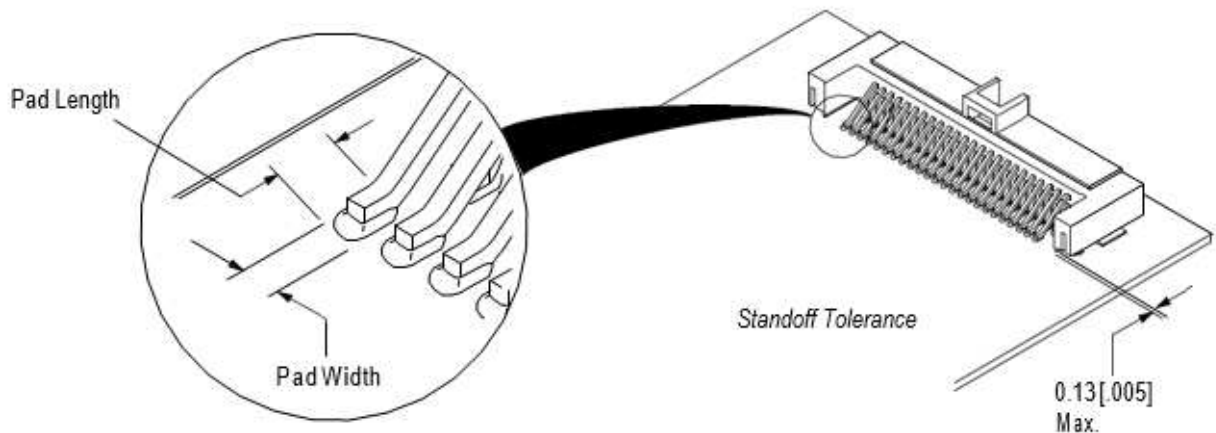

Figure 16

### 3.11. IDC RIBBON CABLE PREPARATION

The only preparation for the cable is to be sure it is cut squarely. We recommend the use a guillotine- type cutter with a cable guide at a right- angle to the cutting blade. See Figure 17.

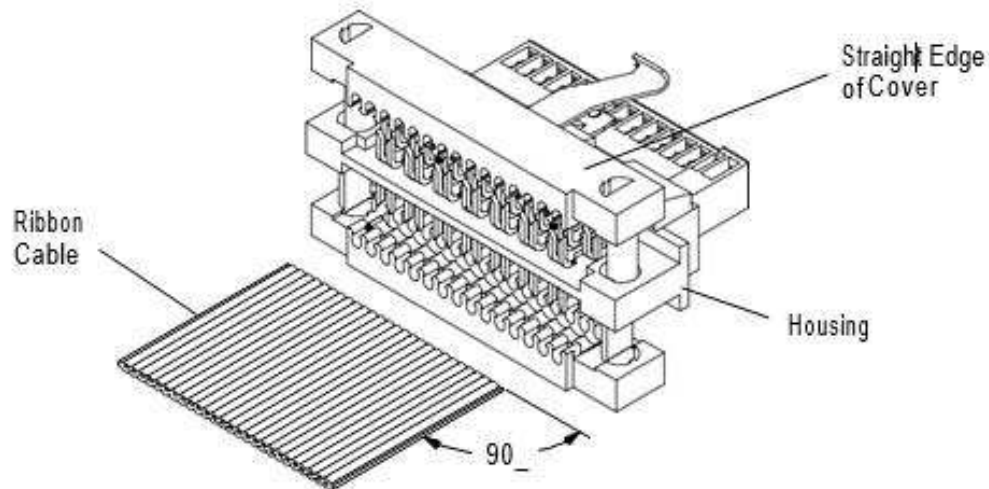

Figure 17

### 3.12. IDC COVER PLACEMENT

The covers are symmetrical and must be started into the housing before positioning the cable for termination. The straight edge of the cover must be toward the housing. See Figure 17.

#### NOTE



Refer to Section 5 for the tooling recommended to terminate the connectors.

### 3.13. INSPECTION OF TERMINATED IDC CONNECTORS

External and internal inspections can be made on terminated connectors. All terminated connectors can be inspected externally. Internal inspections should be made during setup and periodically to ensure that the connectors are being properly applied. Connectors used for internal inspection must be discarded after inspection.

#### A. External Inspection (Figure 18)

1. Check the terminated connector for electrical continuity.
2. Connector must be perpendicular to edge of cable within the tolerance provided.
3. The straight edge of both covers must be toward the housing.
4. The terminated cable end must be visible between the cover and housing.
5. Terminated covers must be seated within the dimension provided.

External Inspection

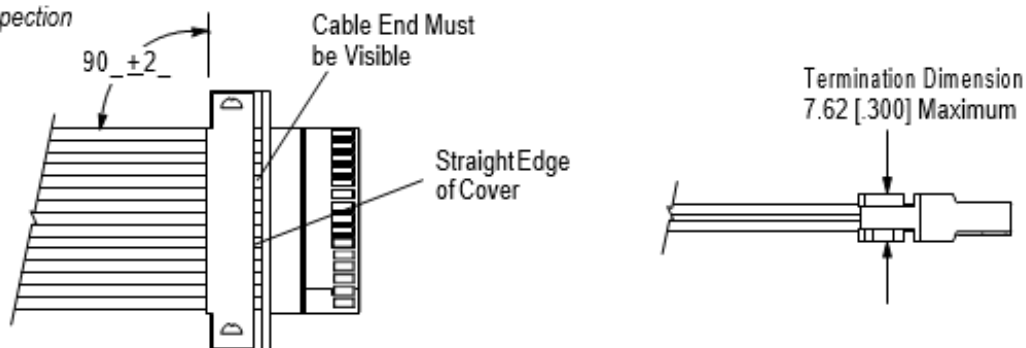

Figure 18

**B. Internal Inspection** (Figure 19)

1. Carefully remove both covers and check that each conductor is terminated.
2. Make sure that all contacts have penetrated the cable and that none are bent or deformed.
3. Make sure the conductors and contacts are placed in accordance with requirements provided.

Internal Inspection

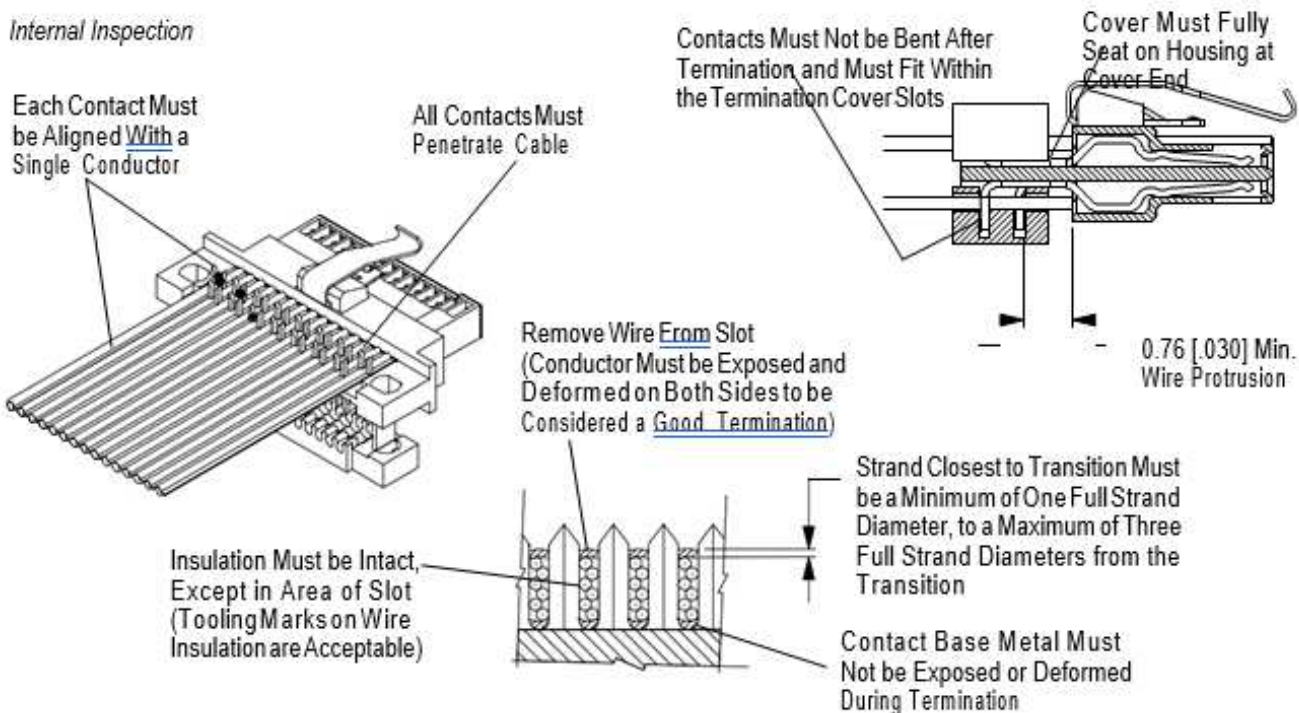

Figure 19



### 3.14. MATING AND UNMATING



*The use of uneven or off-angle forces during mating and unmating of the connectors could cause over-stress and damage to the contacts and/or housings. Do NOT use the “peel-back” method of unmating one end and pulling it until the other end is unmated. Also, do NOT use a severe side-to-side rocking motion to unmate connectors.*

Connectors must be pushed straight in when mating and pulled straight out when unmating. A slight side- to- side motion may be used to start extraction, but it must not continue through full extraction cycle.

Miniaturization is a design feature of these connectors and the systems in which they are used. Component density, connector location, and pc board size may make it difficult to hold one connector in place while extracting the other. Two methods are recommended to facilitate removal. The preferred method is to have one of the pc boards securely fastened and adequately supported to withstand the pulling force applied to the other pc board. The second method is to construct a tool for your system design that will produce a straight- away separation of the connectors.

### 4. QUALIFICATIONS

The AMPMODU 50/50 Grid SMT and IDC Connectors are Listed by the following agencies.

#### 4.8. UNDERWRITERS LABORATORIES INC. (UL)

The connectors are Listed in UL File Number E28476.

#### 4.9. CANADIAN STANDARDS ASSOCIATION (CSA)

The connectors are Certified in File Number LR 7189- A00255.

## 5. TOOLING

A manual miniature arbor frame assembly and cover closing kit have been designed to terminate ribbon cable to IDC connectors. The tool and applicable instruction sheet are shown in Figure 20.

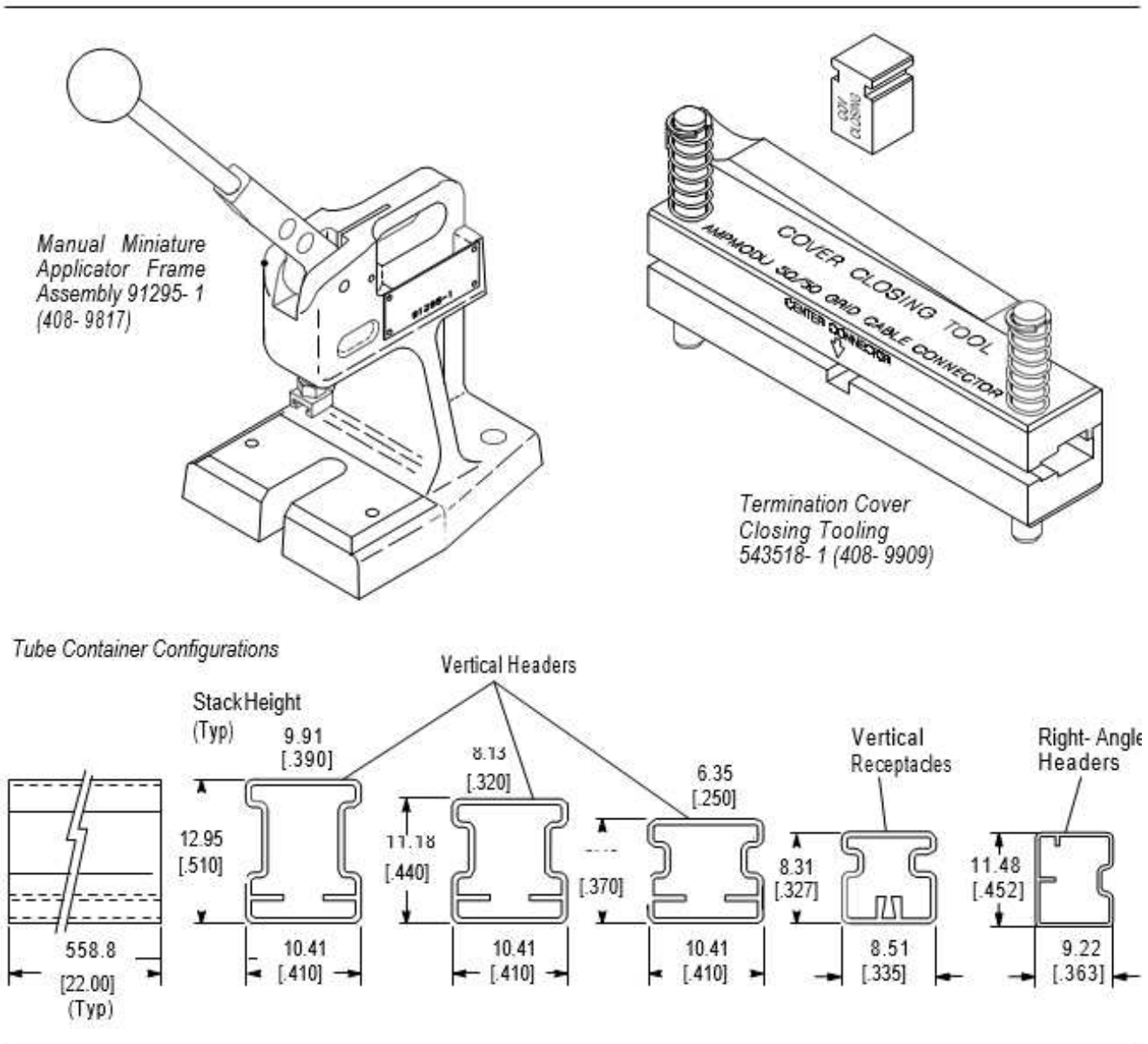

Figure 20

## 6. VISUAL AID

Figure 21 shows typical surface mount and insulation displacement connectors and are intended for use by production personnel to visually ensure suitable applications. Installations which appear visually incorrect should be dimensional inspected using the information given in the preceding pages of this application specification.

### 6.1. SURFACE MOUNT TECHNOLOGY (SMT) CONNECTORS

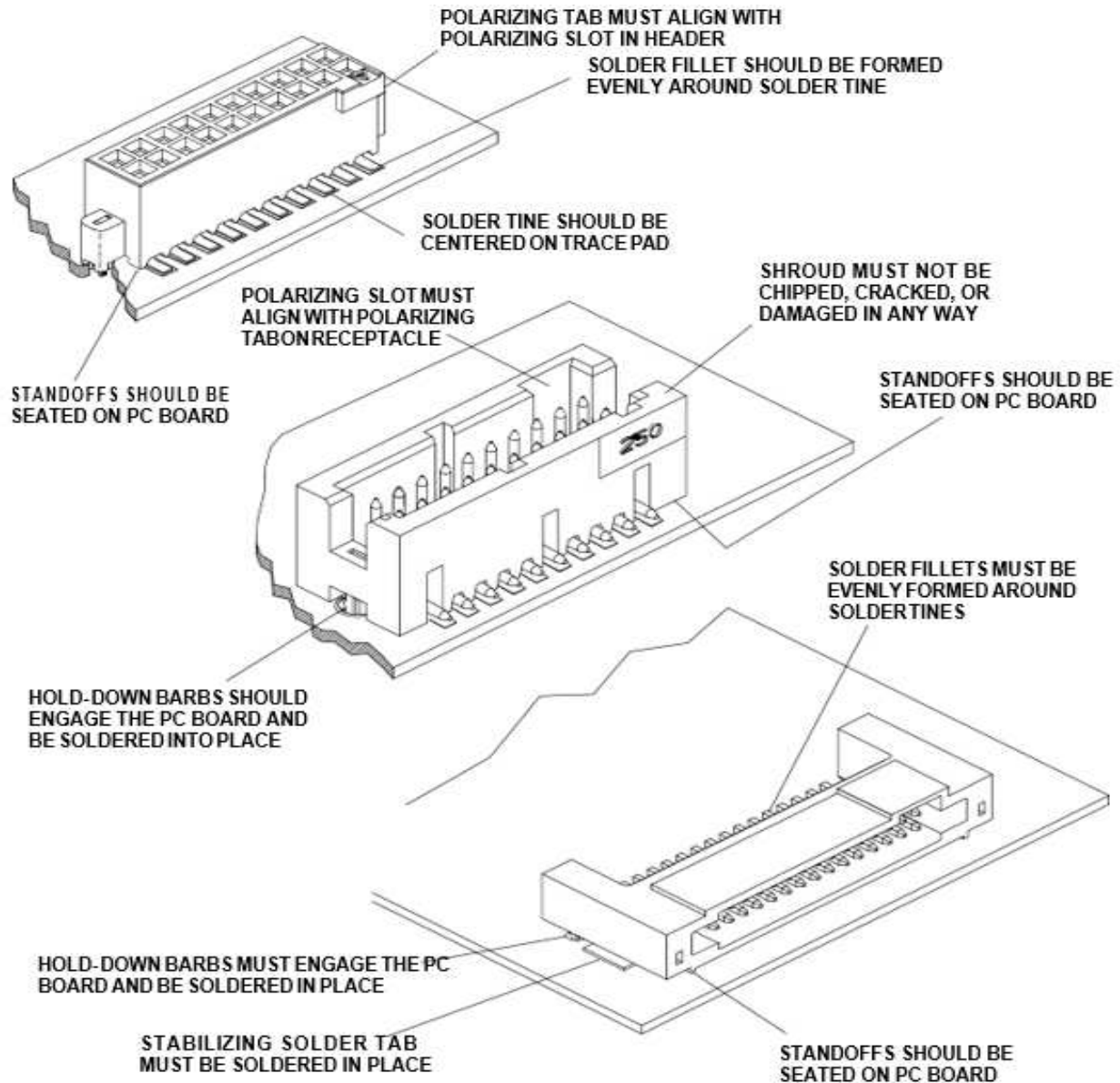

FIGURE 21. VISUAL AID (cont'd)

## 6.2. INSULATION DISPLACEMENT CONNECTORS (IDC)

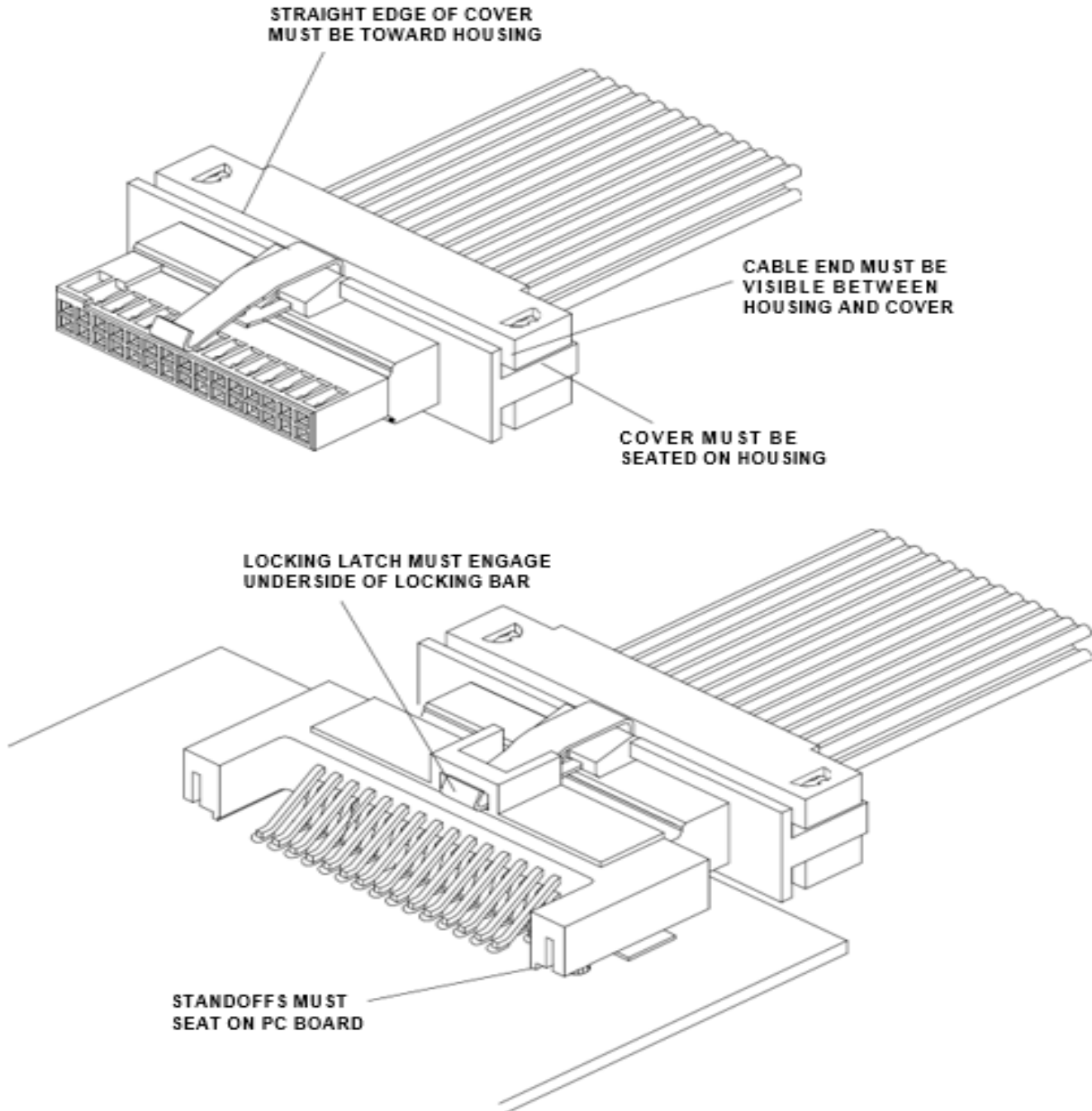

FIGURE 21. VISUAL AID (end)



单击下面可查看定价，库存，交付和生命周期等信息

[>>TE Connectivity\(泰科\)](#)