

THIS DRAWING IS UNPUBLISHED. RELEASED FOR PUBLICATION  
 © COPYRIGHT BY TYCO ELECTRONICS CORPORATION. ALL RIGHTS RESERVED.

LOC	DIST	REVISIONS					
		P	LTR	DESCRIPTION	DATE	DWN	APVD
G	14		A	REDRAWN PER ECR 05-010490	08SEP05	JR	TM
			A1	REVISED PER ECO-09-020935	29AUG09	KK	AEG

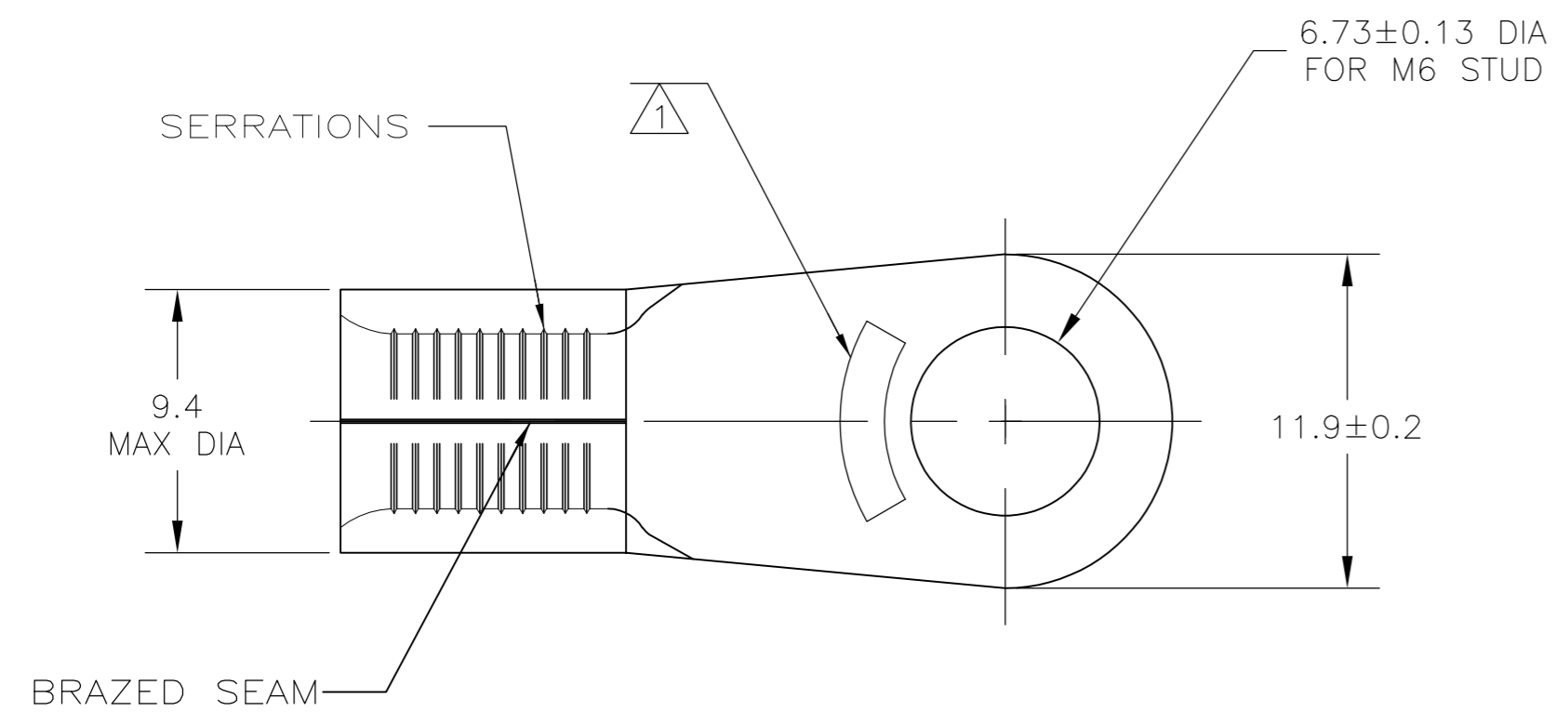

**AMP**  
WIRE RANGE

6 AWG  
SOLID OR STRANDED

- 1 STAMP AMP 6\* APPROX AS SHOWN
- 2 COPPER PER ASTM B-152, ANNEALED
- 3 MAX OPERATING TEMP IS 170°C
- 4 WIRE CROSS SECTIONAL AREA RANGE:  
10.5-16.8mm<sup>2</sup> [20,800-33,100] CIR MILS  
SOLID OR STRANDED WIRE
- 5 OBSOLETE PARTS: OBSOLETE CIS STREAMLINING  
PER D.RENAUD/D.SINISI

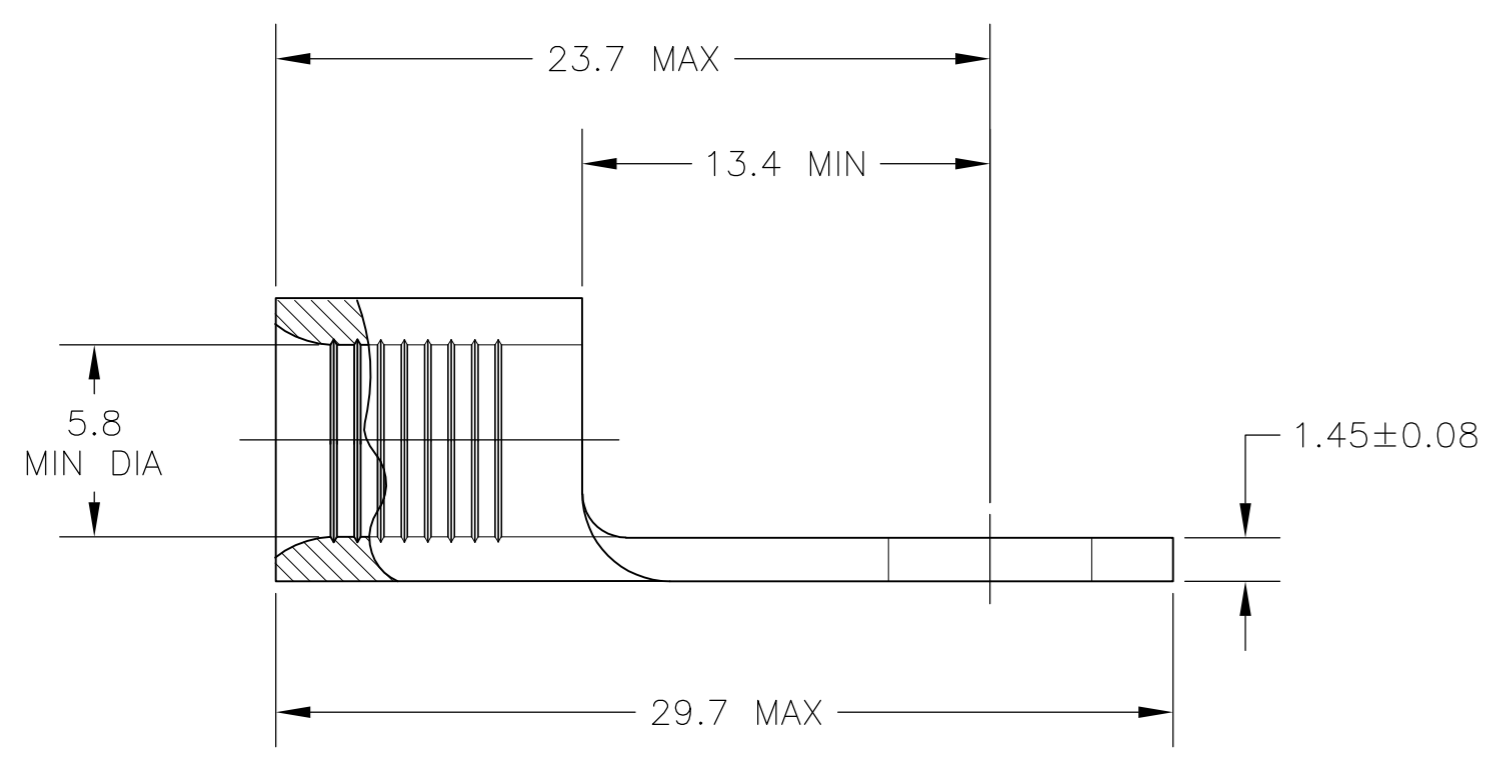

5	OBSOLETE	LOOSE PIECE BOX	25	TIN PLATE 0.00254[.000100] MIN THK PER ASTM B-545	<del>8</del> 130554 <del>1</del>
		LOOSE PIECE	100	TIN PLATE 0.00254[.000100] MIN THK PER ASTM B-545	130554
		PACKAGE TYPE	QTY	FINISH	PART NO.

THIS DRAWING IS A CONTROLLED DOCUMENT.		DWN	JR RUTH	08SEP05	Tyco Electronics Corporation Harrisburg, Pa 17105-3608		
DIMENSIONS: mm <del>INCHES</del>		CHK	T MICHIELUTTI	08SEP05			
TOLERANCES UNLESS OTHERWISE SPECIFIED:		APVD	T MICHIELUTTI	08SEP05			
0 PLC ± - 1 PLC ± - 2 PLC ± - 3 PLC ± - 4 PLC ± - ANGLES ± -		PRODUCT SPEC	NAME				
MATERIAL	FINISH	WEIGHT	SIZE		CAGE CODE	DRAWING NO	RESTRICTED TO
- 2	SEE TABLE	-	A2		00779	C=130554	-
CUSTOMER DRAWING				SCALE	4:1	SHEET	1 OF 1
				REV	A1		

130554

单击下面可查看定价，库存，交付和生命周期等信息

[>>TE Connectivity\(泰科\)](#)