

THIS DRAWING IS UNPUBLISHED. RELEASED FOR PUBLICATION, 19  
 © COPYRIGHT 19 BY AMP INCORPORATED. ALL INTERNATIONAL RIGHTS RESERVED.

LOC	DIST	P	F	ZONE	LTR	DESCRIPTION	DATE	APPD
AF	50				B	REVISE PER ECR-13-013738	15FEB14	GRZ/JL

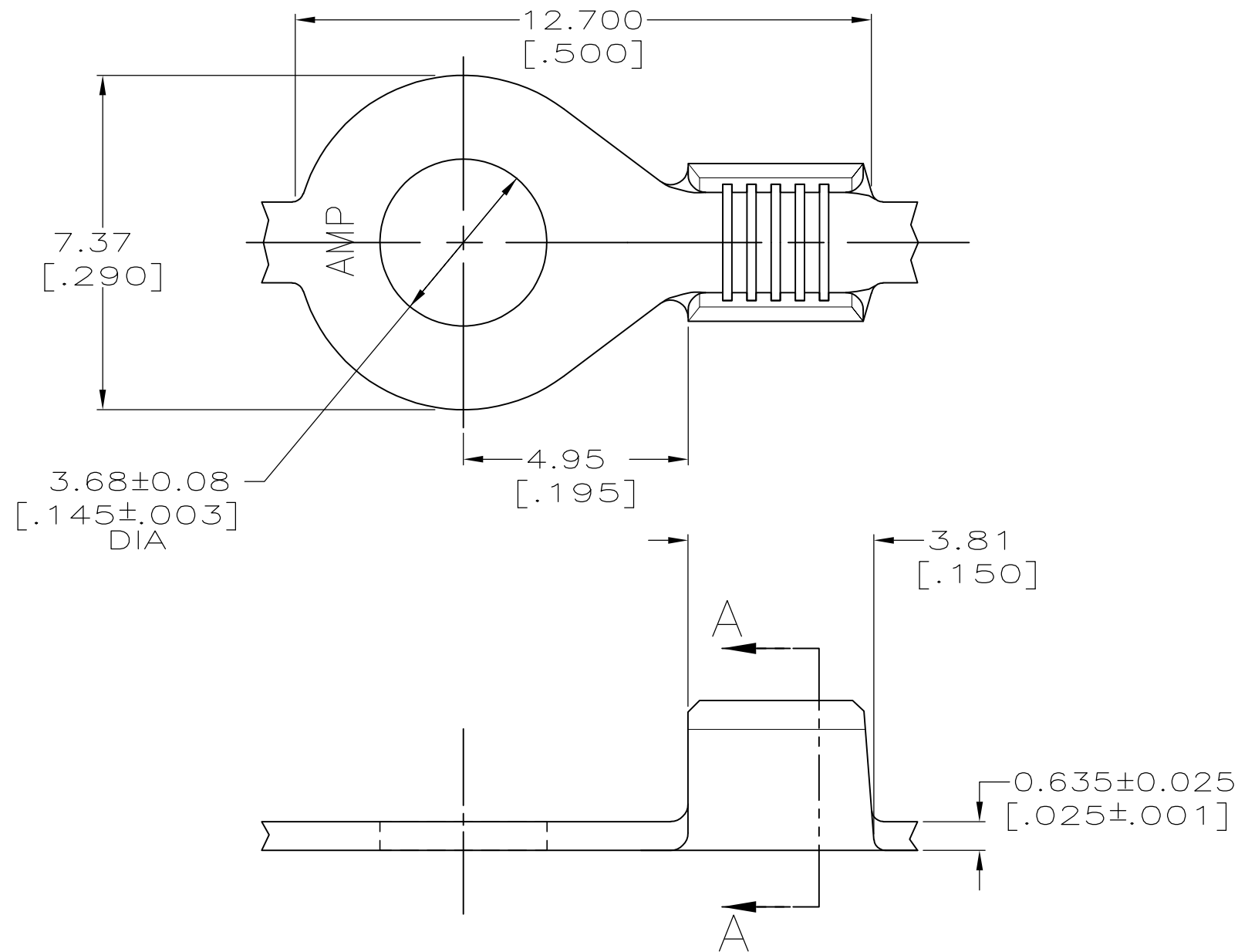

1 CONTINUOUS STRIP ON REEL.

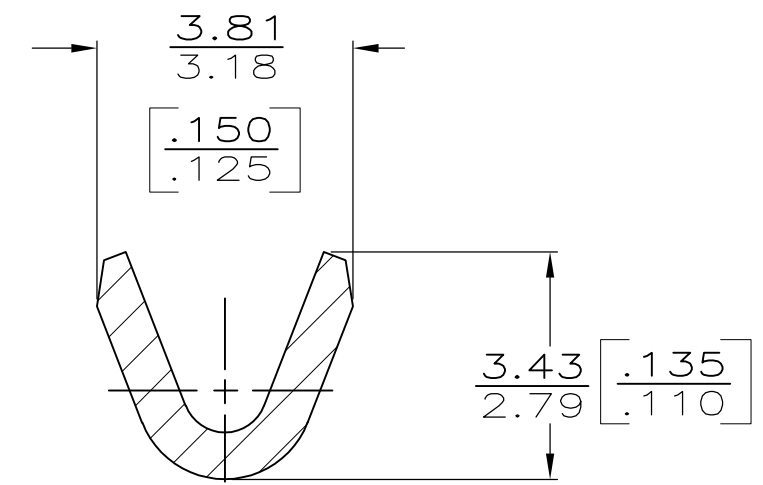

SECTION A-A  
SCALE 10:1

F		2.79 [0.110]	1.47 [0.058]	0.8mm <sup>2</sup> [18]	0.64-1.02mm DIA [22-18] AWG		63649-1
TYPE		WIDTH	±0.051 [0.002] HEIGHT	WIRE	MAGNET WIRE RANGE		PART NO
WIRE BARREL CRIMP							
DO NOT SCALE PRINT. UNLESS SPECIFIED DIMENSIONS IN mm [INCHES] TOLERANCES ON:				DR 5/6/92 P FORTNEY		AMP Incorporated Harrisburg, PA 17105-3608	
2 PLC DEC ± 0.25 [0.010]				CHK 5/6/92 MS FEHER			
3 PLC DEC ± -				APPD 5/6/92 G YETTER		NAME RING,AMPLIVAR	
ANGLES ± -				APPD 5/6/92 R WEAVILL			
MATERIAL BRASS				PRODUCT SPEC -		SIZE B	
FINISH 0.002032 [0.000080] MIN TIN PL PER MIL-T-10727				APPLICATION SPEC -		CAGE CODE 00779	
THIS DRAWING IS A CONTROLLED DOCUMENT FOR AMP INCORPORATED. IT IS SUBJECT TO CHANGE AND THE CONTROLLING ENGINEERING ORGANIZATION SHOULD BE CONTACTED FOR THE LATEST REVISION.				WEIGHT -		DRAWING NO C-63649	
						SCALE 8:1	
						SHEET 1 OF 1	

单击下面可查看定价，库存，交付和生命周期等信息

[>>TE Connectivity\(泰科\)](#)