

NUMBER  
C-1734796

3RD ANGLE PROJECTION

METRIC

THIS INFORMATION IS CONFIDENTIAL AND IS DISCLOSED TO YOU ON CONDITION THAT NO FURTHER DISCLOSURE IS MADE BY YOU TO OTHER THAN AMP PERSONNEL WITHOUT WRITTEN AUTHORIZATION FROM AMP (TAIWAN) LTD. DIMENSIONS IN MILLIMETERS. DO NOT SCALE PRINT.

PRINT  
DW

CIRCUIT NO.  
1 SIDE

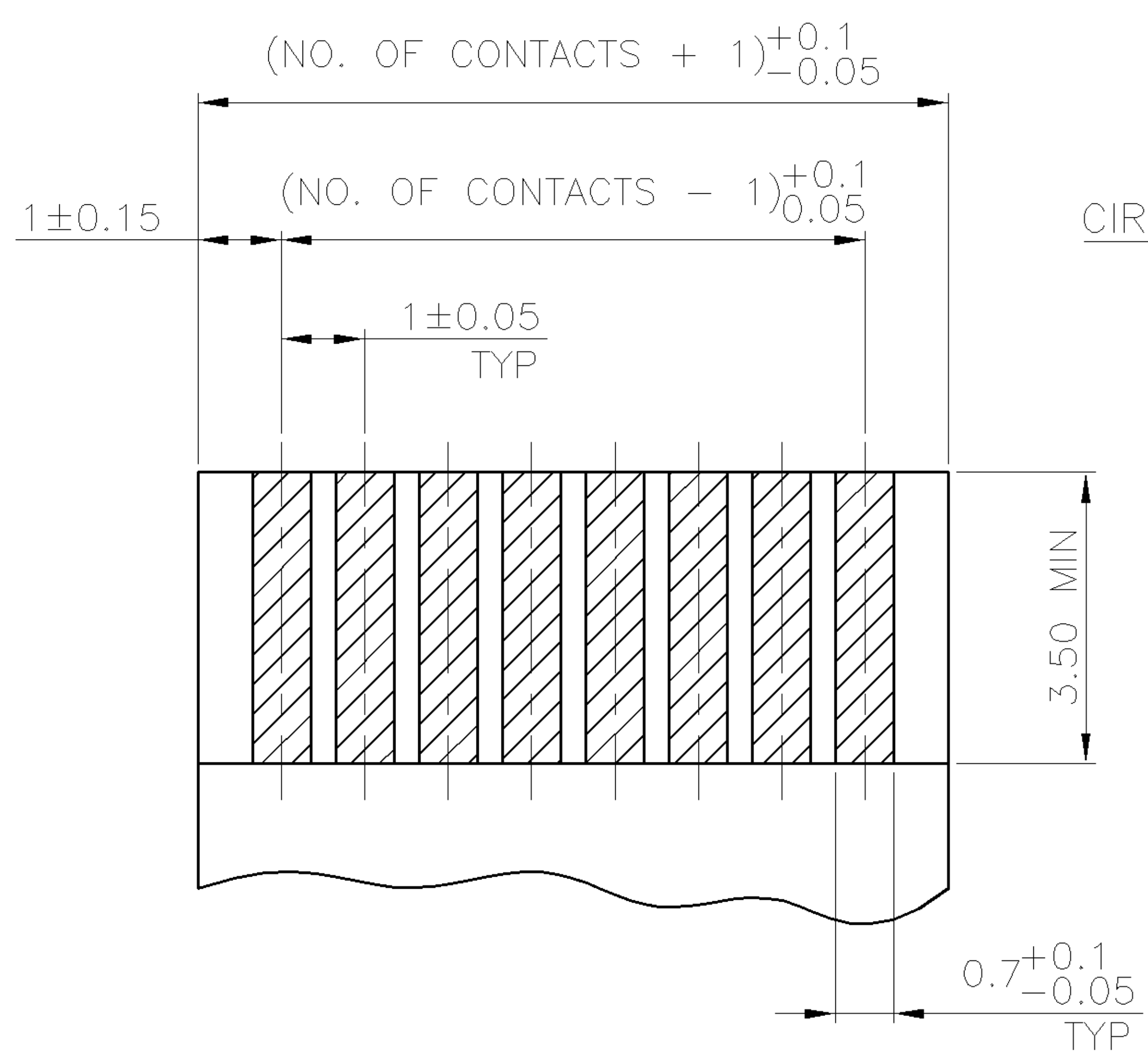
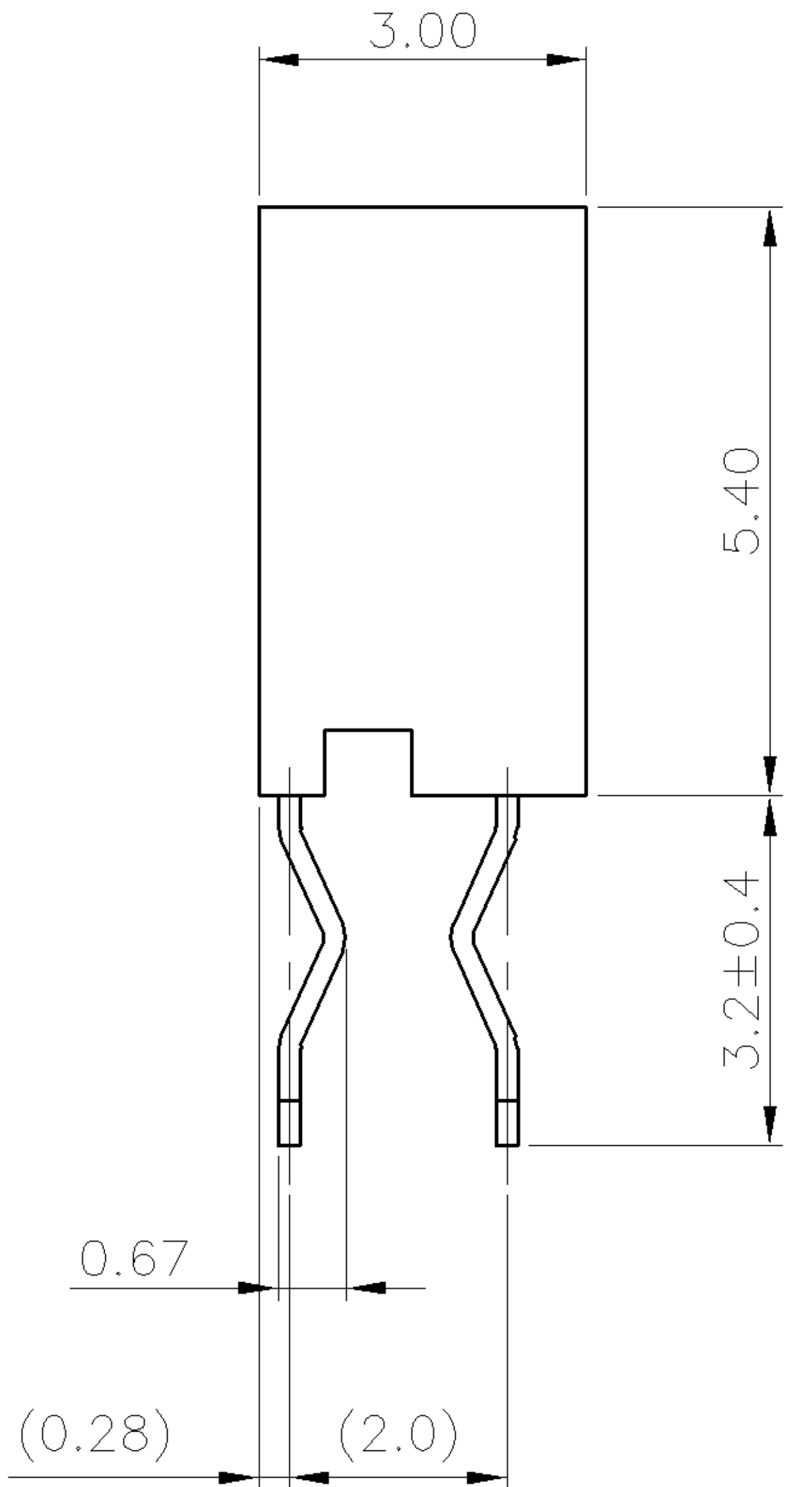
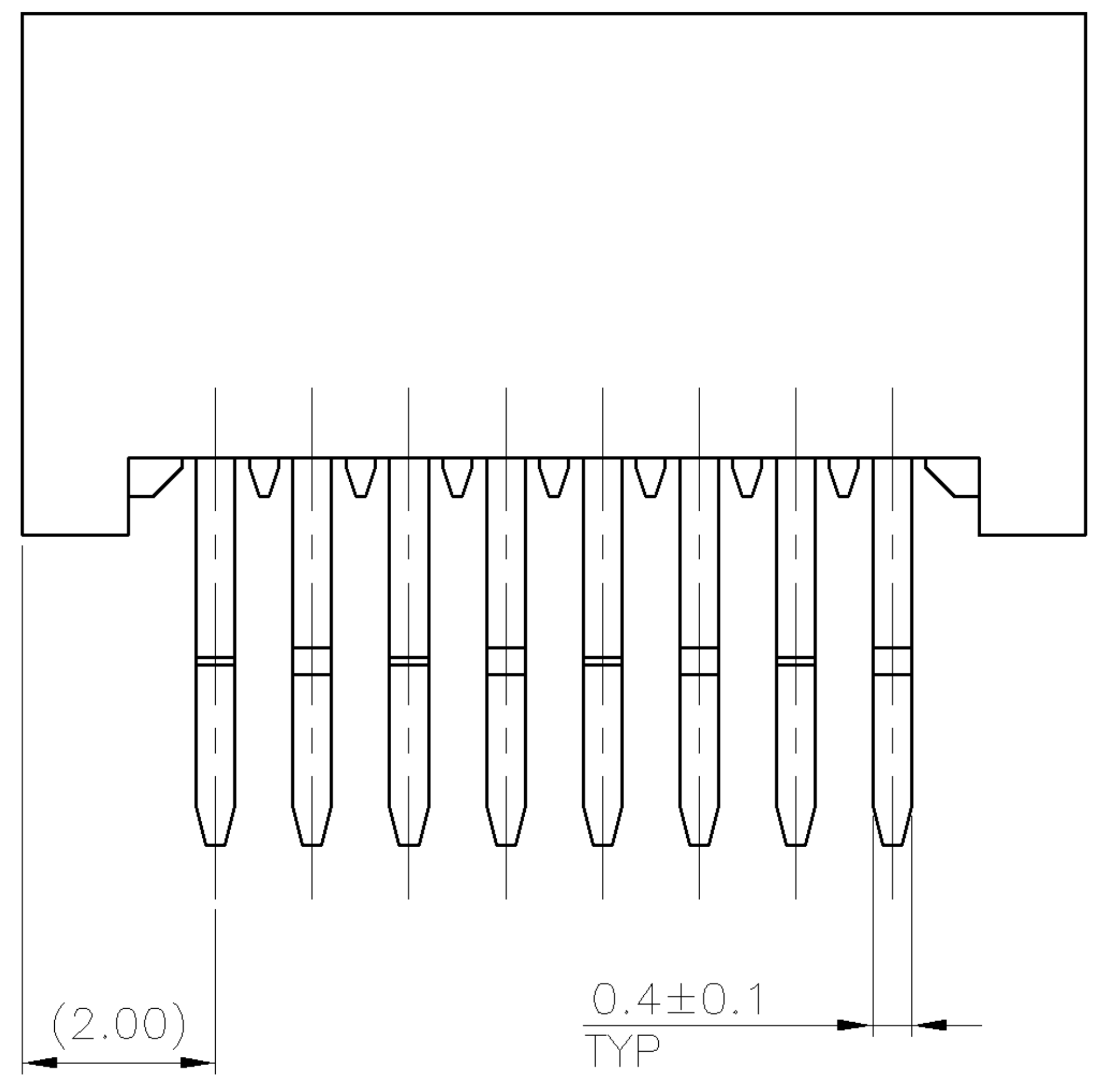
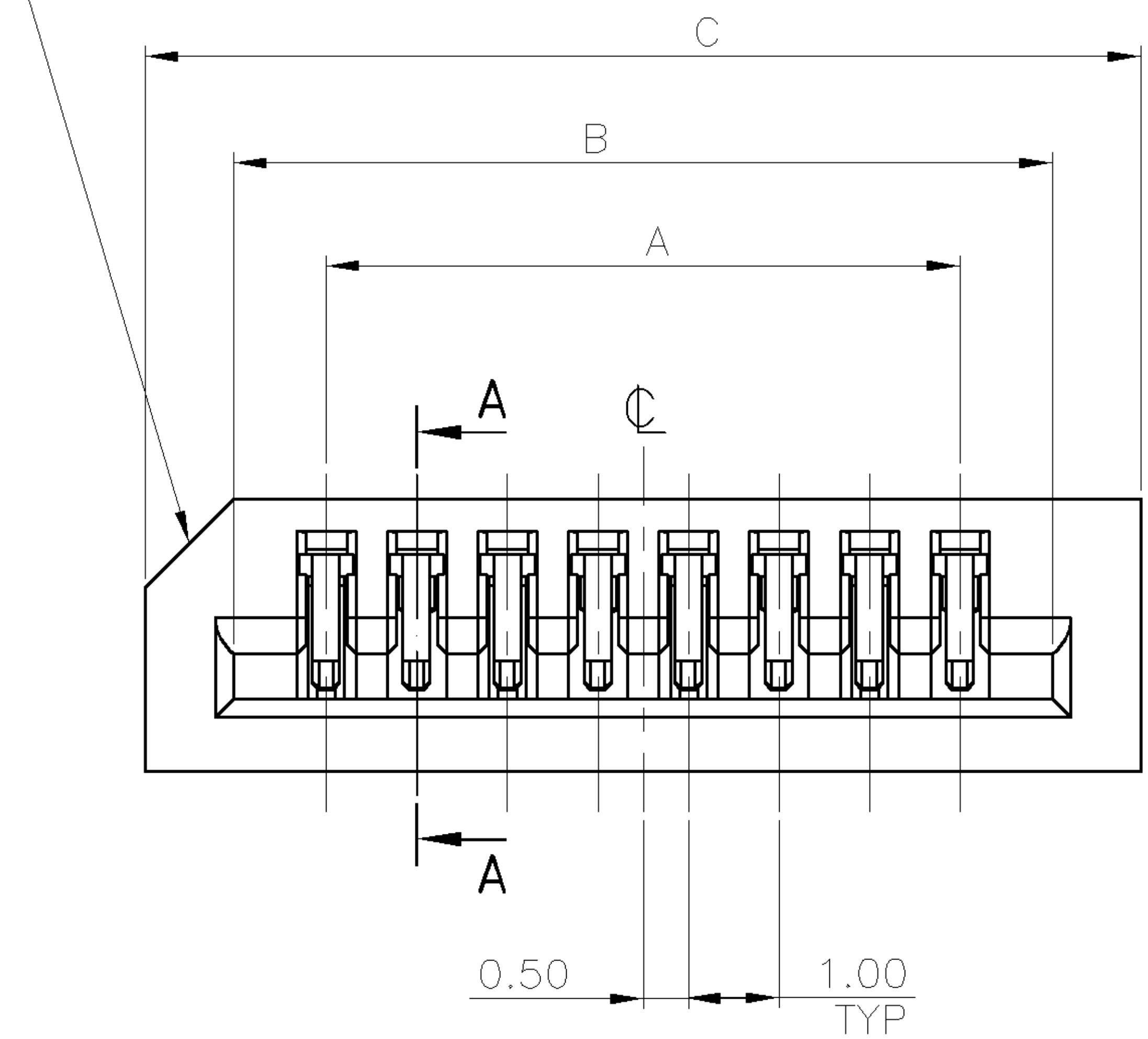

RECOMMENDED FPC LAYOUT  
(THICKNESS= 0.3±0.05)

CIRCUIT NO. 1

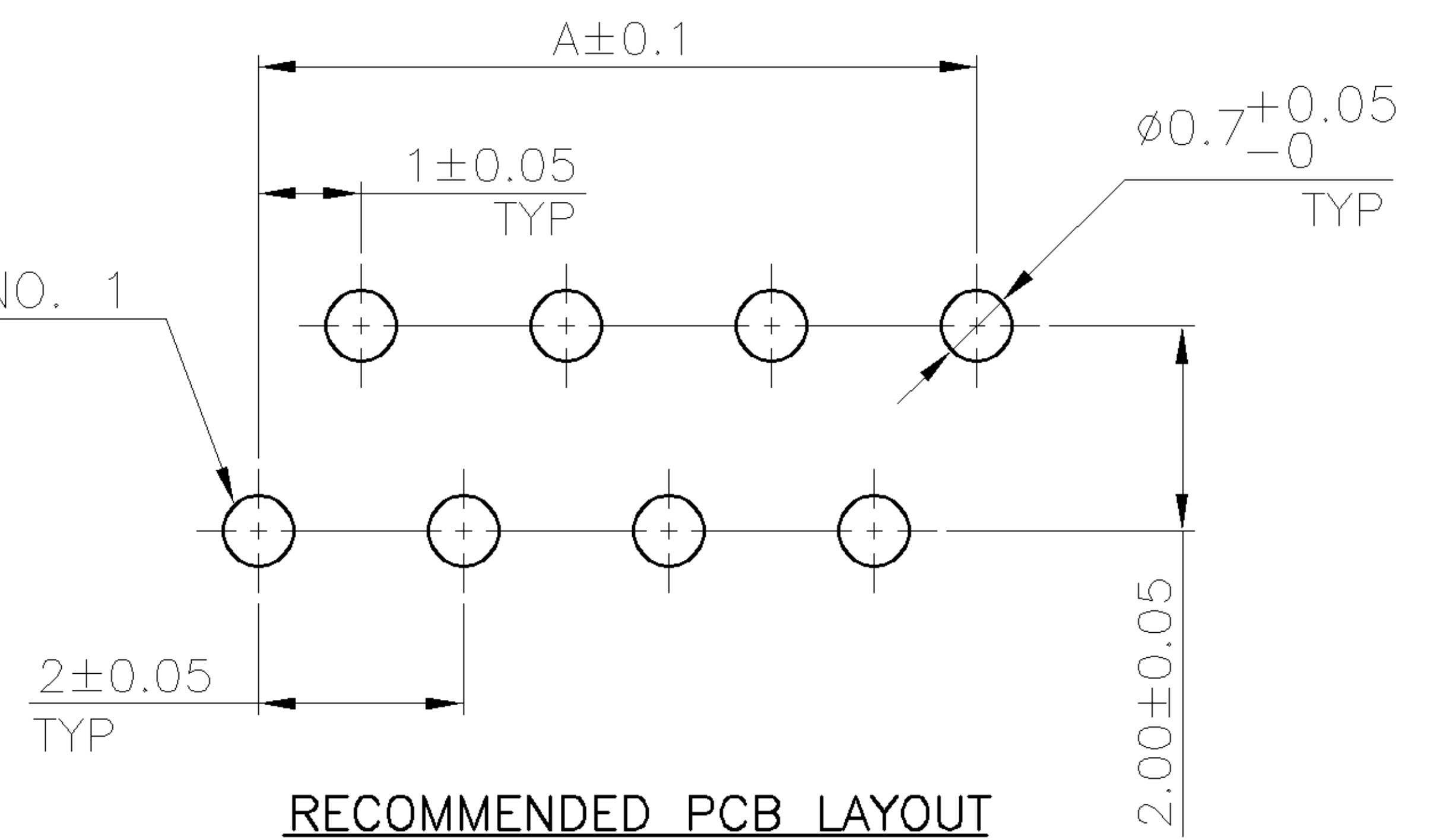

RECOMMENDED PCB LAYOUT  
TYPE A  
(THICKNESS= 1.60)

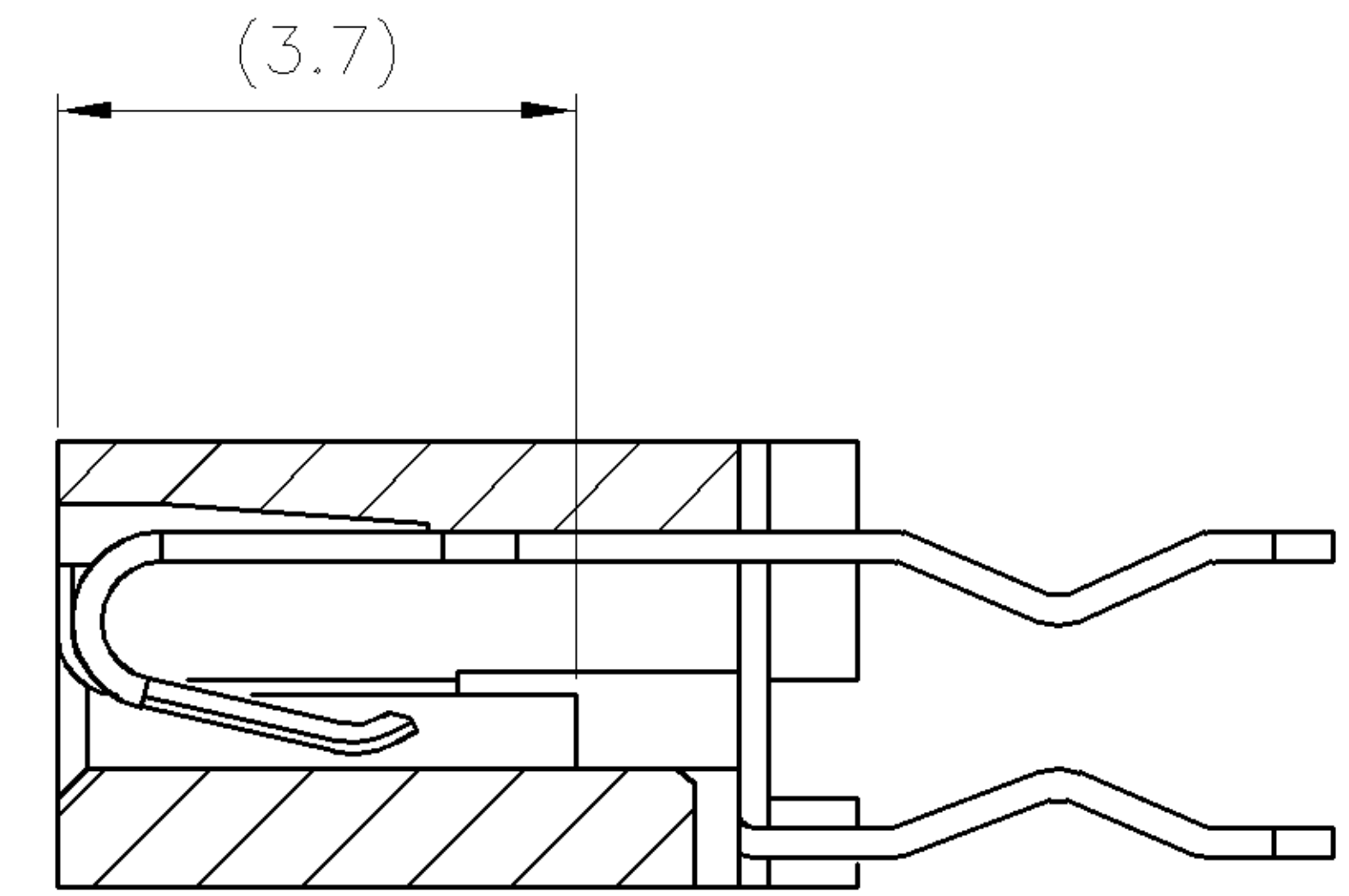

SECTION A-A

OBSOLETE

0.74 g	33.00	31.05	29.00	30	3-1734796-0
0.72 g	32.00	30.05	28.00	29	2-1734796-9
0.69 g	31.00	29.05	27.00	28	2-1734796-8
0.67 g	30.00	28.05	26.00	27	2-1734796-7
0.65 g	29.00	27.05	25.00	26	2-1734796-6
0.63 g	28.00	26.05	24.00	25	2-1734796-5
0.60 g	27.00	25.05	23.00	24	2-1734796-4
0.58 g	26.00	24.05	22.00	23	2-1734796-3
0.56 g	25.00	23.05	21.00	22	2-1734796-2
0.53 g	24.00	22.05	20.00	21	2-1734796-1
0.51 g	23.00	21.05	19.00	20	2-1734796-0
0.49 g	22.00	20.05	18.00	19	1-1734796-9
0.47 g	21.00	19.05	17.00	18	1-1734796-8
0.44 g	20.00	18.05	16.00	17	1-1734796-7
0.42 g	19.00	17.05	15.00	16	1-1734796-6
0.40 g	18.00	16.05	14.00	15	1-1734796-5
0.38 g	17.00	15.05	13.00	14	1-1734796-4
0.35 g	16.00	14.05	12.00	13	1-1734796-3
0.33 g	15.00	13.05	11.00	12	1-1734796-2
0.31 g	14.00	12.05	10.00	11	1-1734796-1
0.29 g	13.00	11.05	9.00	10	1-1734796-0
0.26 g	12.00	10.05	8.00	9	1734796-9
0.24 g	11.00	9.05	7.00	8	1734796-8
0.22 g	10.00	8.05	6.00	7	1734796-7
0.20 g	9.00	7.05	5.00	6	1734796-6
0.17 g	8.00	6.05	4.00	5	1734796-5
0.15 g	7.00	5.05	3.00	4	1734796-4
WEIGHT	C	B	A	NO. OF CONTACTS	PART NUMBER

NOTE:

- MATERIAL:  
HOUSING: THERMOPLASTIC UL 94V-0, BLACK COLOR.  
CONTACTS: PHOSPHOR BRONZE.
- FINISH:  
CONTACTS: 120μ" MIN. MATTE-TIN OVER 50μ" MIN. NICKEL ON ENTIRE CONTACT.
- NO TYCO LOGO AND DATE CODE ON THE PRODUCT.
- WAVE SOLDER CAPABLE TO 265°C AS PER TYCO SPEC. 109-202, CONDITION B.

B	OBSOLETE PARTS	ECR-15-010901	H.X W.H	09DEC 2015
A	REVISED & ADD PNS	ECR-06-000945	AW SH	13JAN 2006
LTR	REVISION RECORD	ECN	DWN CHK	DATE

TOLERANCES UNLESS OTHERWISE SPECIFIED: 0 PLC ±- 1 PLC ±0.15 2 PLC ±0.1 3 PLC ±- ANGLES ±-	DWN A. WU 13-JAN-2006	<b>tyco</b> TYCO HOLDINGS (BERMUDA) <b>Electronics</b> VII LTD. TAIWAN BRANCH NAME			
MATERIAL SEE NOTE	CHK S. HOU 13-JAN-2006	FPC CONNECTOR, 1.0 PITCH, NON-ZIF, VERTICAL, LAYOUT TYPE A			
FINISH SEE NOTE	APVD W.J. KE 13-JAN-2006	LOC DW	SIZE A <sub>3</sub>	DRAWING NO C-1734796	REV B
	PRODUCT SPEC 108-57354	SCALE --	SHEET 1 OF 2		
	QUALIFICATION TEST REPORT 501-57449				
	WEIGHT SEE TABLE				

THIS INFORMATION IS CONFIDENTIAL AND IS DISCLOSED TO YOU ON CONDITION THAT NO FURTHER DISCLOSURE IS MADE BY YOU TO OTHER THAN AMP PERSONNEL WITHOUT WRITTEN AUTHORIZATION FROM AMP (TAIWAN) LTD. DIMENSIONS IN MILLIMETERS. DO NOT SCALE PRINT.

PRINT DIST  
DW

METRIC

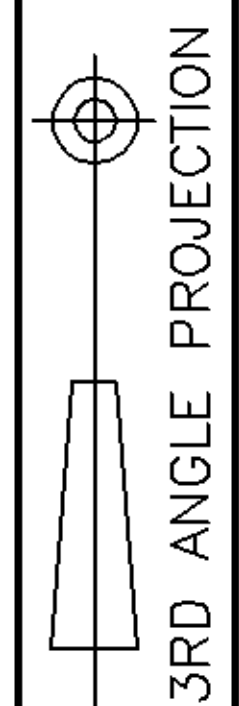

NUMBER  
C-1734796

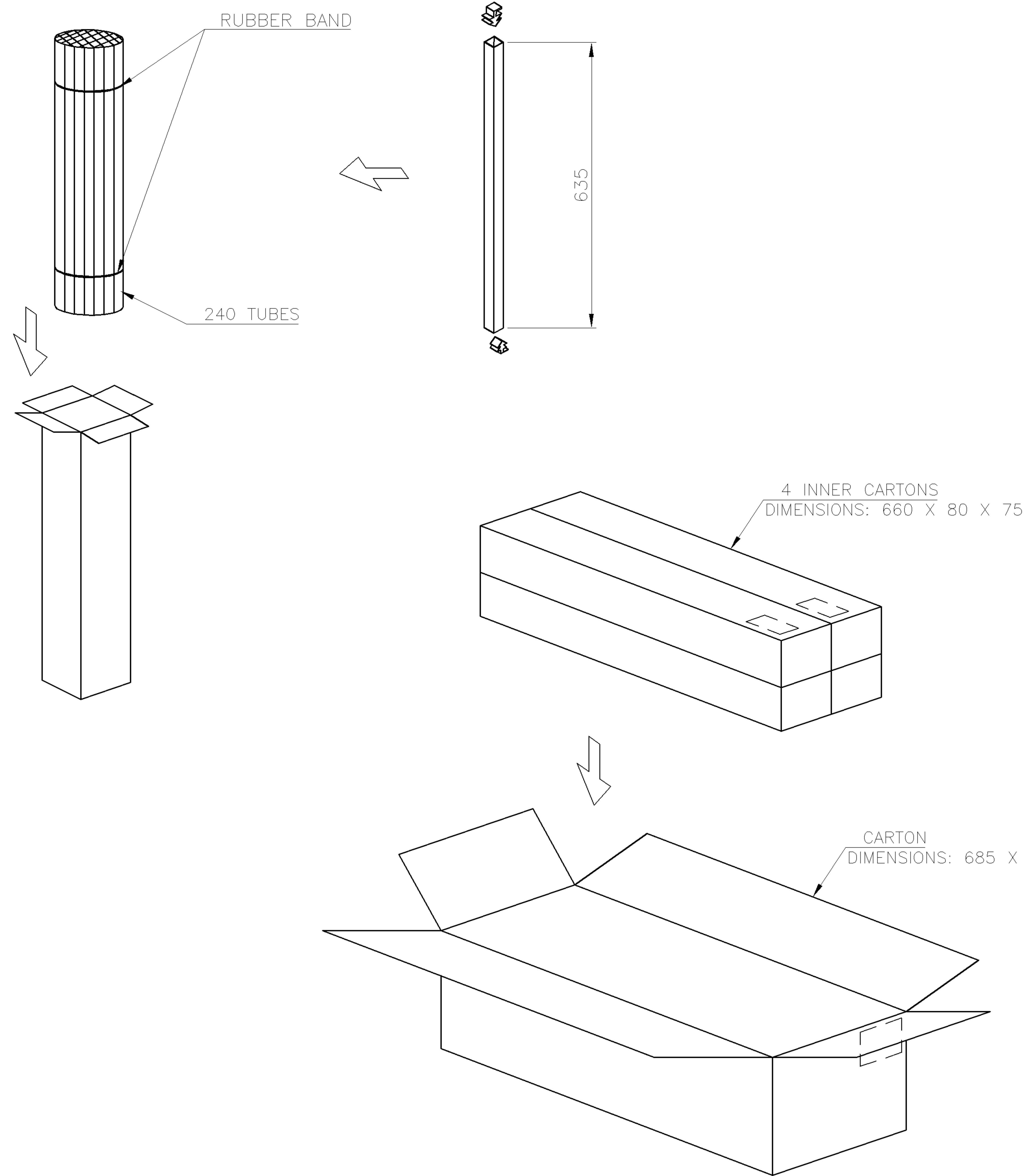

PCS/TUBE	QUANTITY	G/W (KG)	N/W (KG)	NO. OF CONTACTS
18	4320	8.80	3.20	30
18	4320	8.71	3.11	29
19	4560	8.75	3.15	28
20	4800	8.82	3.22	27
20	4800	8.72	3.12	26
21	5040	8.78	3.18	25
22	5280	8.77	3.17	24
23	5520	8.80	3.20	23
24	5760	8.83	3.23	22
25	6000	8.78	3.18	21
26	6240	8.78	3.18	20
27	6480	8.79	3.18	19
28	6720	8.76	3.16	18
30	7200	8.77	3.17	17
31	7440	8.72	3.12	16
33	7920	8.77	3.17	15
35	8400	8.79	3.19	14
37	8880	8.71	3.11	13
40	9600	8.77	3.17	12
43	10320	8.80	3.20	11
46	11040	8.80	3.21	10
50	12000	8.72	3.12	9
55	13200	8.77	3.17	8
60	14400	8.77	3.17	7
67	16080	8.82	3.22	6
75	18000	8.66	3.06	5
86	20640	8.70	3.10	4

TOLERANCES UNLESS OTHERWISE SPECIFIED: 0 PLC ±- 1 PLC ±- 2 PLC ±- 3 PLC ±- ANGLES ±-		DWN A. WU 13-JAN-2006	<b>tyco</b> TYCO HOLDINGS (BERMUDA) <b>Electronics</b> VII LTD. TAIWAN BRANCH	
MATERIAL -	APVD W.J. KE 13-JAN-2006	CHK S. HOU 13-JAN-2006	NAME FPC CONNECTOR, 1.0 PITCH, NON-ZIF, VERTICAL, LAYOUT TYPE A	
FINISH -	PRODUCT SPEC	APPLICATION SPEC	LOC DW	REV B
	WEIGHT	SCALE --	DRAWING NO C-1734796	SHEET 2 OF 2

SEE SHEET 1.	ECN	DWN	CHK	DATE
LTR	REVISION RECORD			

单击下面可查看定价，库存，交付和生命周期等信息

[>>TE Connectivity\(泰科\)](#)