

THIS DRAWING IS UNPUBLISHED. RELEASED FOR PUBLICATION
 (C) COPYRIGHT 19 BY AMP INCORPORATED. ALL RIGHTS RESERVED.

LOC	DIST	REVISIONS					
		P	LTR	DESCRIPTION	DATE	DWN	APVD
G	86		B	REV PER 0G3A-0561-01	090CT02	JR	MS

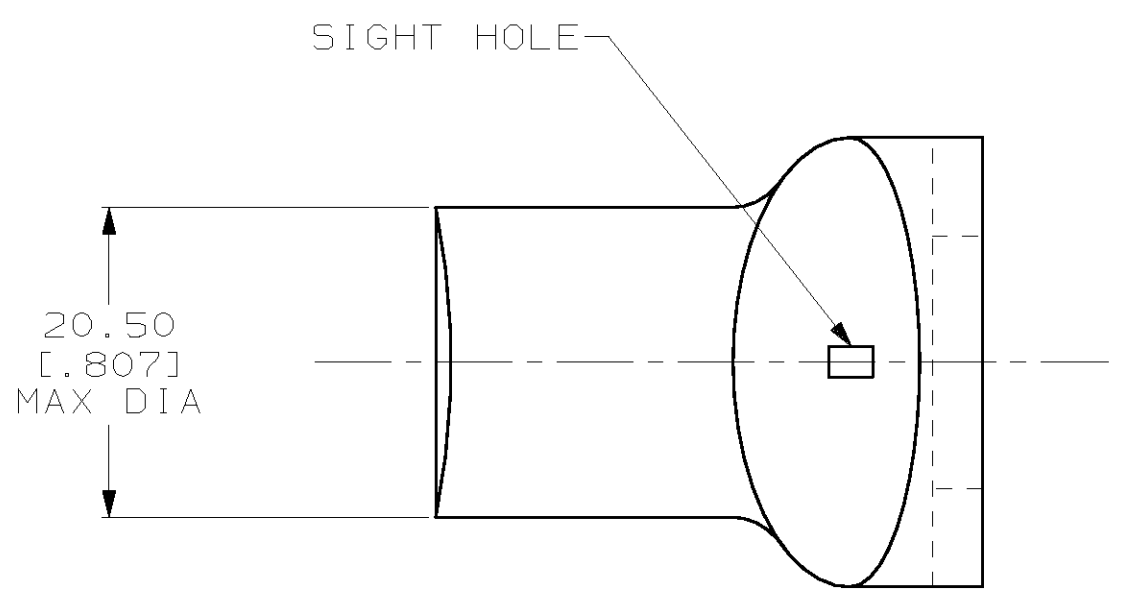

- ① COPPER PER ASTM B-75 ANNEALED
- ② NICKEL PLATE 0.00254 [.000100] MIN THK PER QQ-N-290

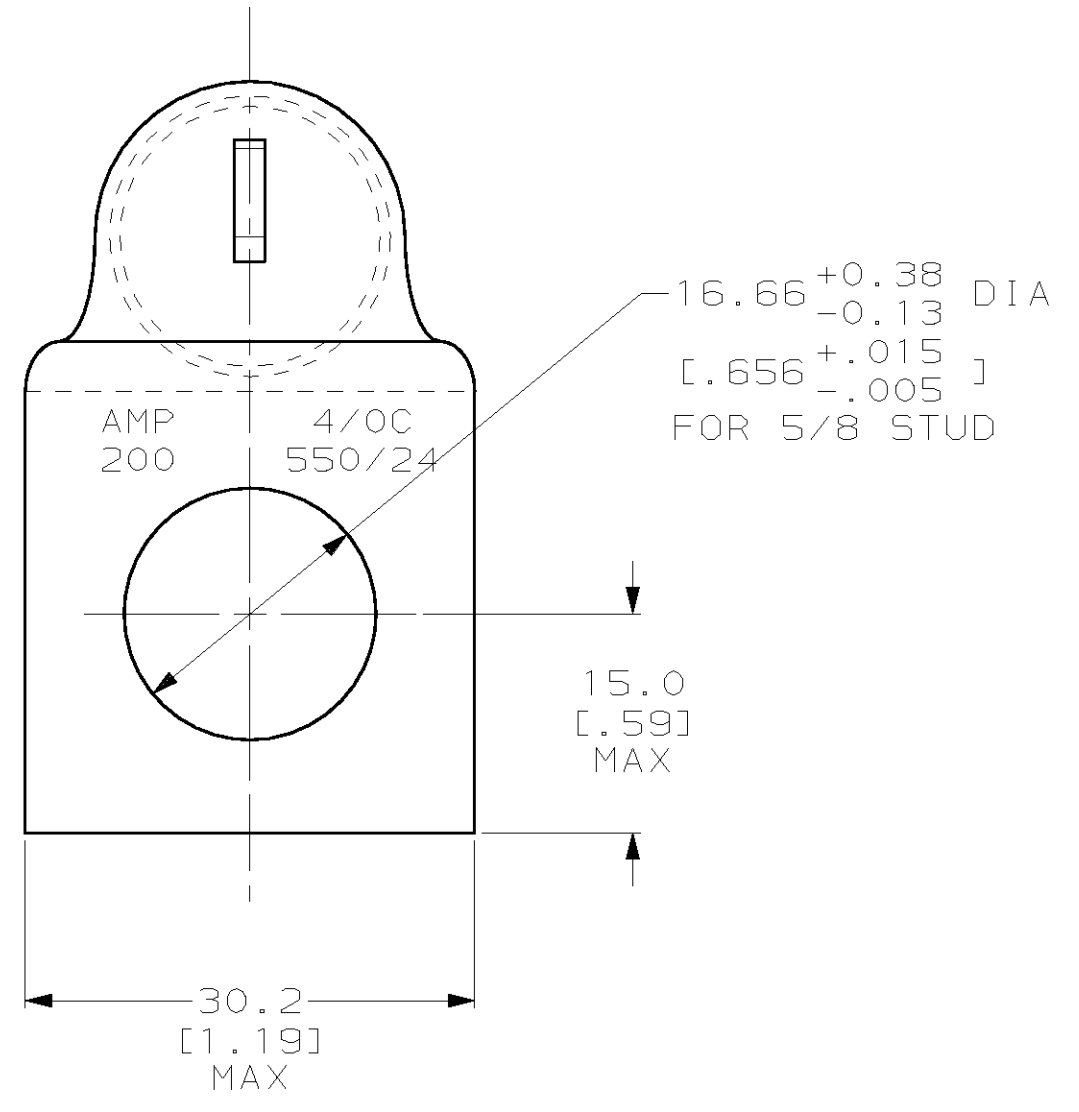
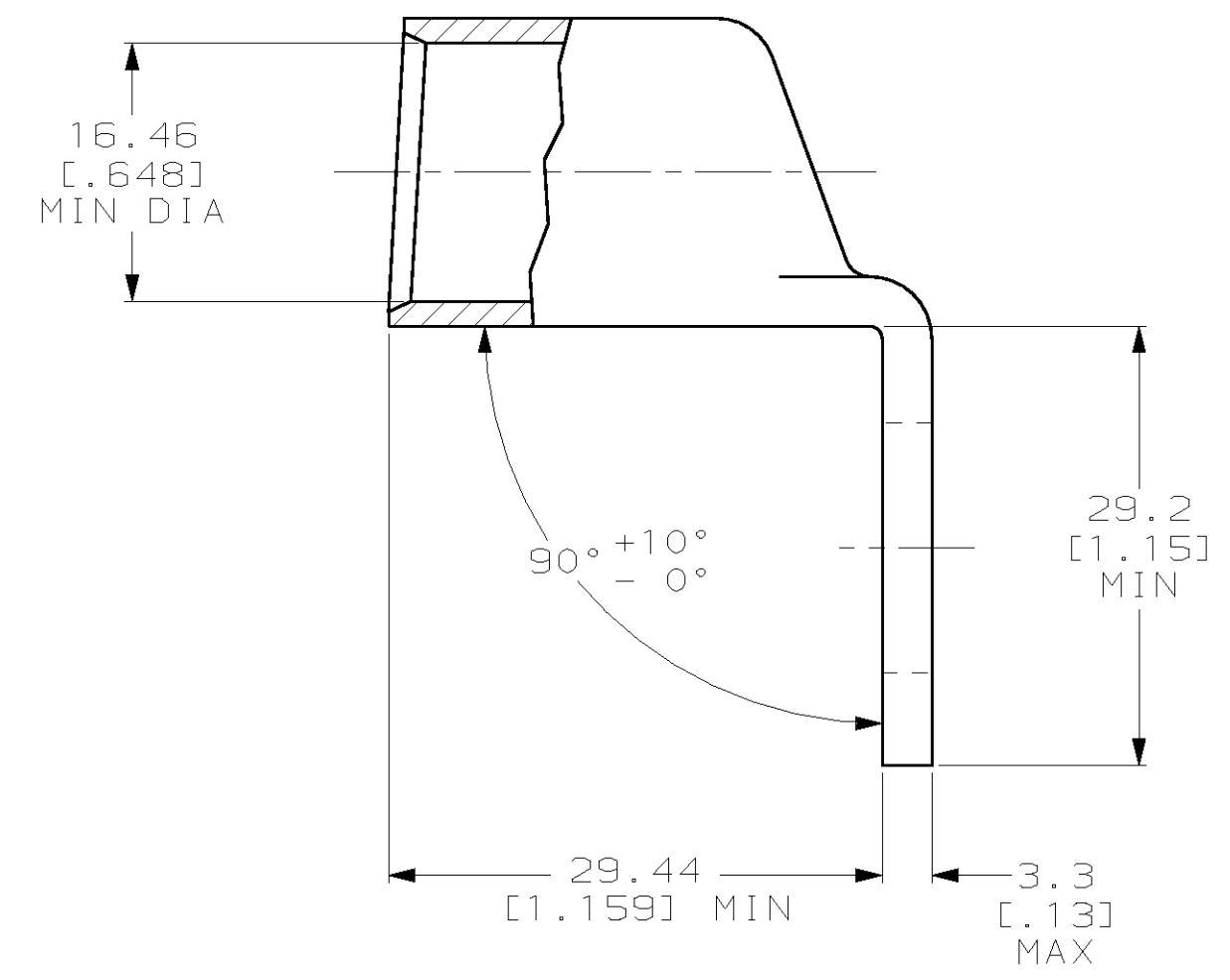

696123-1
AMP
PART NUMBER

AMP INCORPORATED CUSTOMER SERVICE SYSTEMS		RECOMMENDED OPERATING TEMPERATURE: -
FOR ADDITIONAL PRODUCT INFORMATION OR COPIES OF DRAWINGS AND TECHNICAL DOCUMENTS	PRODUCT INFORMATION CENTER 1-800-522-6752	VOLTAGE RATING: NOT APPLICABLE
FOR APPLICATION TOOLING INFORMATION	TOOLING ASSISTANCE CENTER 1-800-722-1111	WIRE CROSS SECTIONAL AREA RANGE: 96.3-117.0mm ² [190,000-231,000] CIR MILS SOLID OR STRANDED
FOR ORDER ENTRY	1-800-526-5142	

THIS DRAWING IS A CONTROLLED DOCUMENT.		DWN JR RUTH 140CT99	AMP AMP Incorporated Harrisburg, PA 17105-3608
DIMENSIONS: mm [INCHES]		CHK M SPICER 140CT99	
TOLERANCES UNLESS OTHERWISE SPECIFIED:		APVD M SPICER 140CT99	NAME M SPICER
0 PLC ± 1 PLC ± 2 PLC ±0.51 [.020] 3 PLC ± 4 PLC ±		PRODUCT SPEC -	APPLICATION SPEC 114-2150
MATERIAL - ①		FINISH - ②	SIZE A2
		CUSTOMER DRAWING	CAGE CODE 00779
			DRAWING NO C-696123
			WEIGHT .106 lbs
			SCALE 2:1
			SHEET 1 OF 1
			REV B

单击下面可查看定价，库存，交付和生命周期等信息

[>>TE Connectivity\(泰科\)](#)