

LOC	DIST	REV	DATE	BY	CHK	APPD
FX	00					
B		REVISED PER ECO-10-010364	21SEP2010	DLD	CJS	
B1		REVISED PER ECO-11-005947	22MAR2011	DLD	CJS	

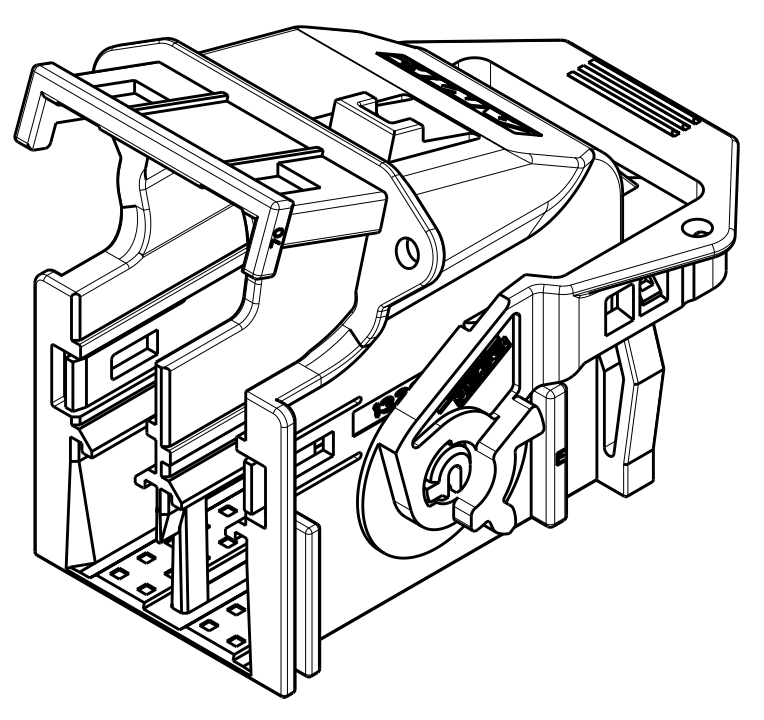

SCALE 2:1

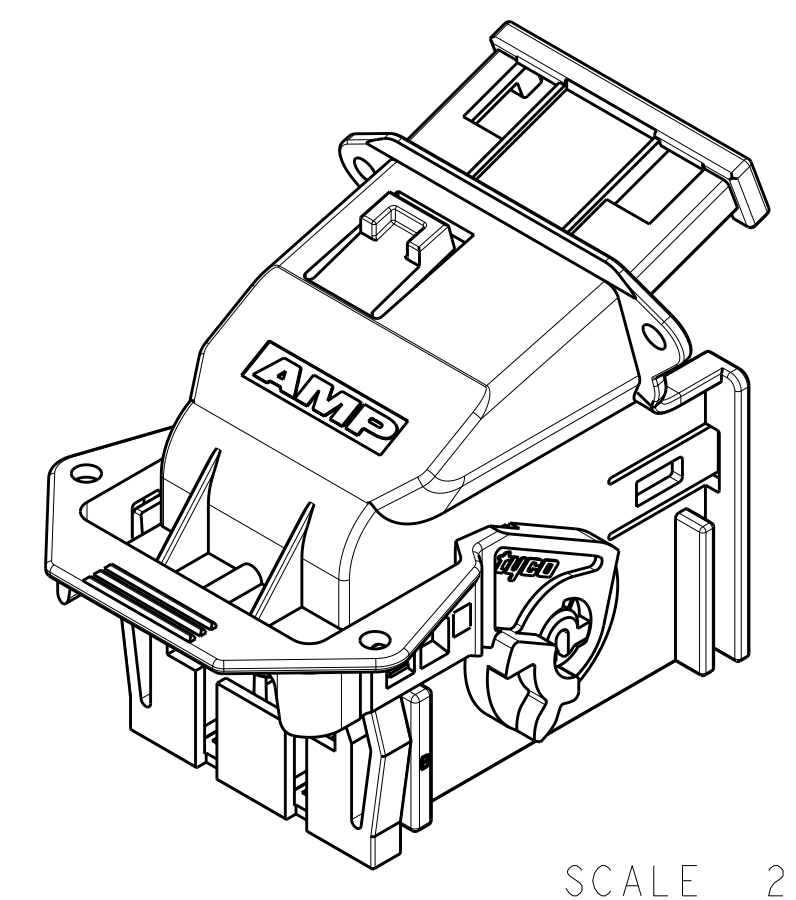
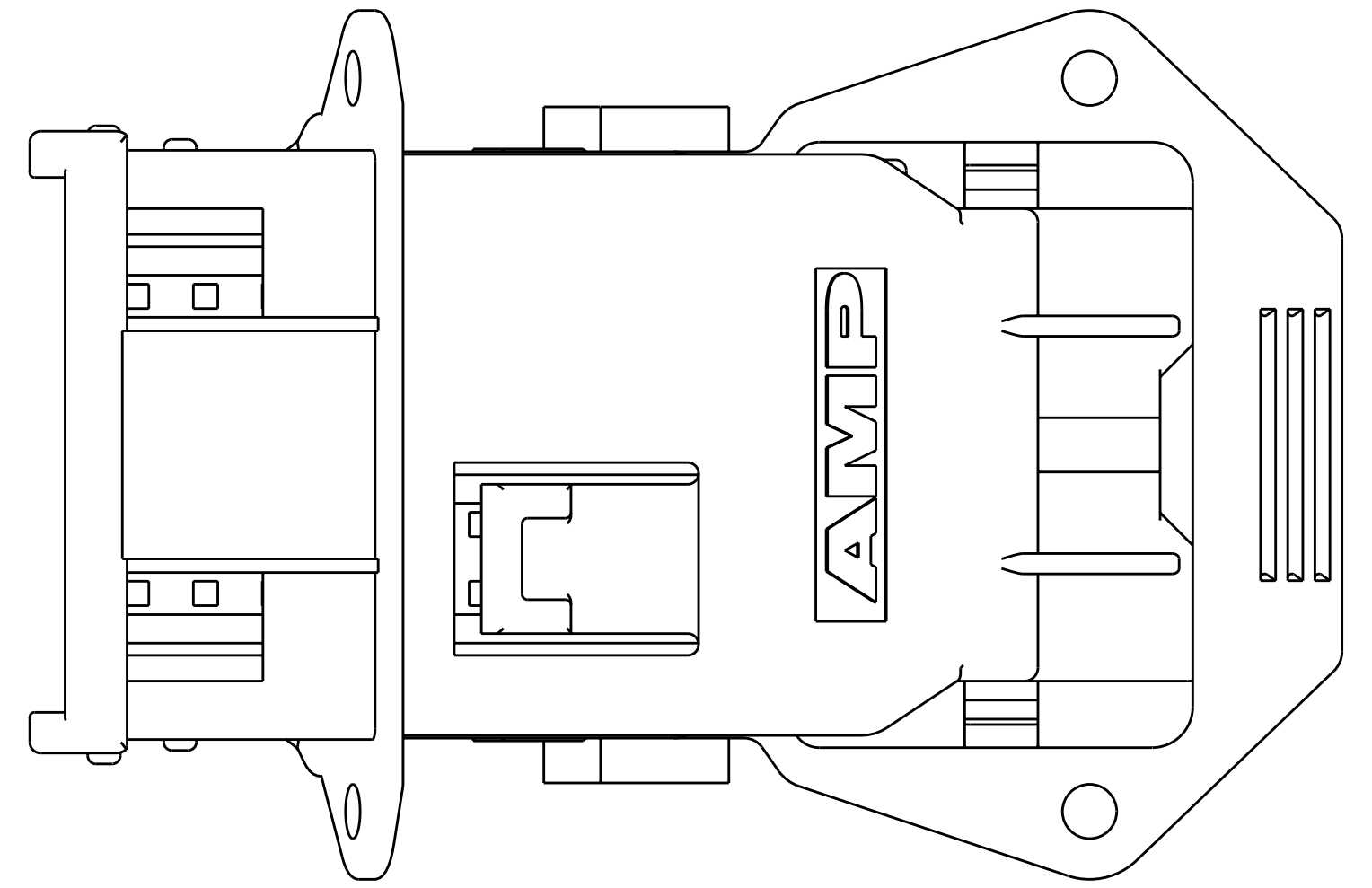

SCALE 2:1

- 1. MATERIAL: SHIELD - 35% GLASS REINFORCED NYLON. SEE TABLE BELOW FOR COLOR. LEVER - 35% GLASS REINFORCED NYLON. COLOR: DARK GREY.
- 2. ANTI-SCOOPING FEATURE OPTIONAL CONSTRUCTION.
- 3. REFERENCE: RECEPTACLE HOUSING, 1326042-1 & 1326042-2, USED WITH THIS ASSEMBLY.
- 4. REFERENCE: INTERFACE DETAIL PER DRAWING NO. AUAUTO1000-2962-0010 AND TE DRAWING NO. 1438985-GEN.
- 5. REFER TO INSTRUCTION SHEET 408-8662 FOR PRODUCT ASSEMBLY AND DISASSEMBLY PROCEDURES.
- 6. REFER TO USCAR-2 REV 3 APRIL 2001 FOR PRODUCT SPECIFICATIONS.

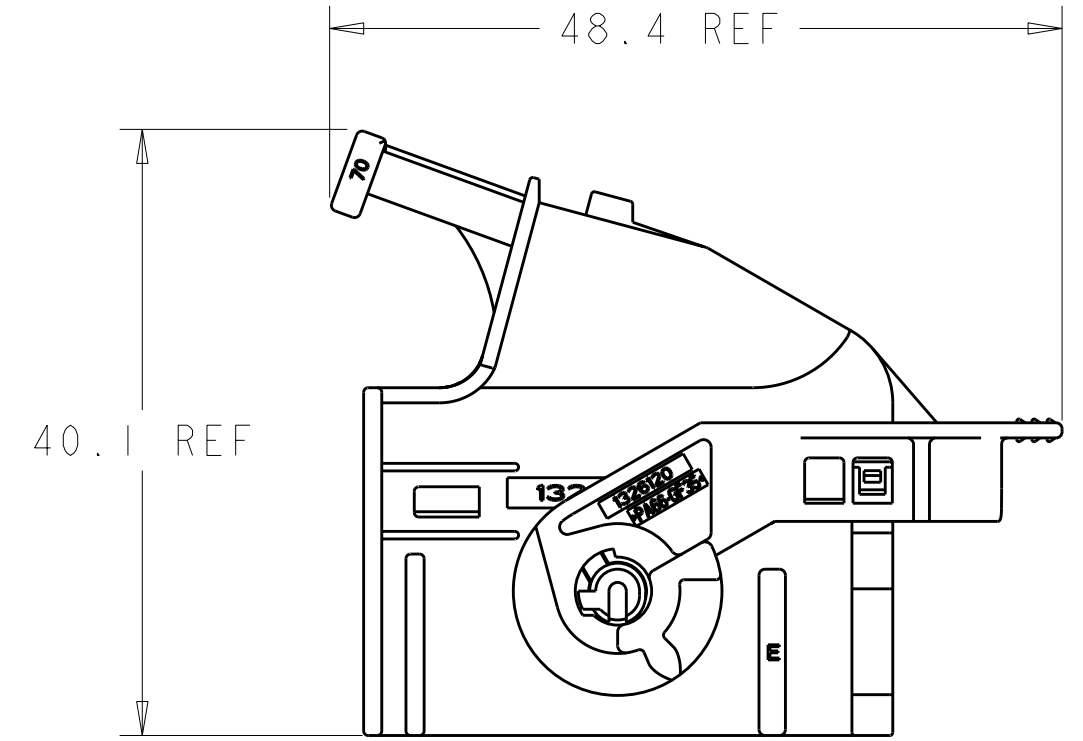
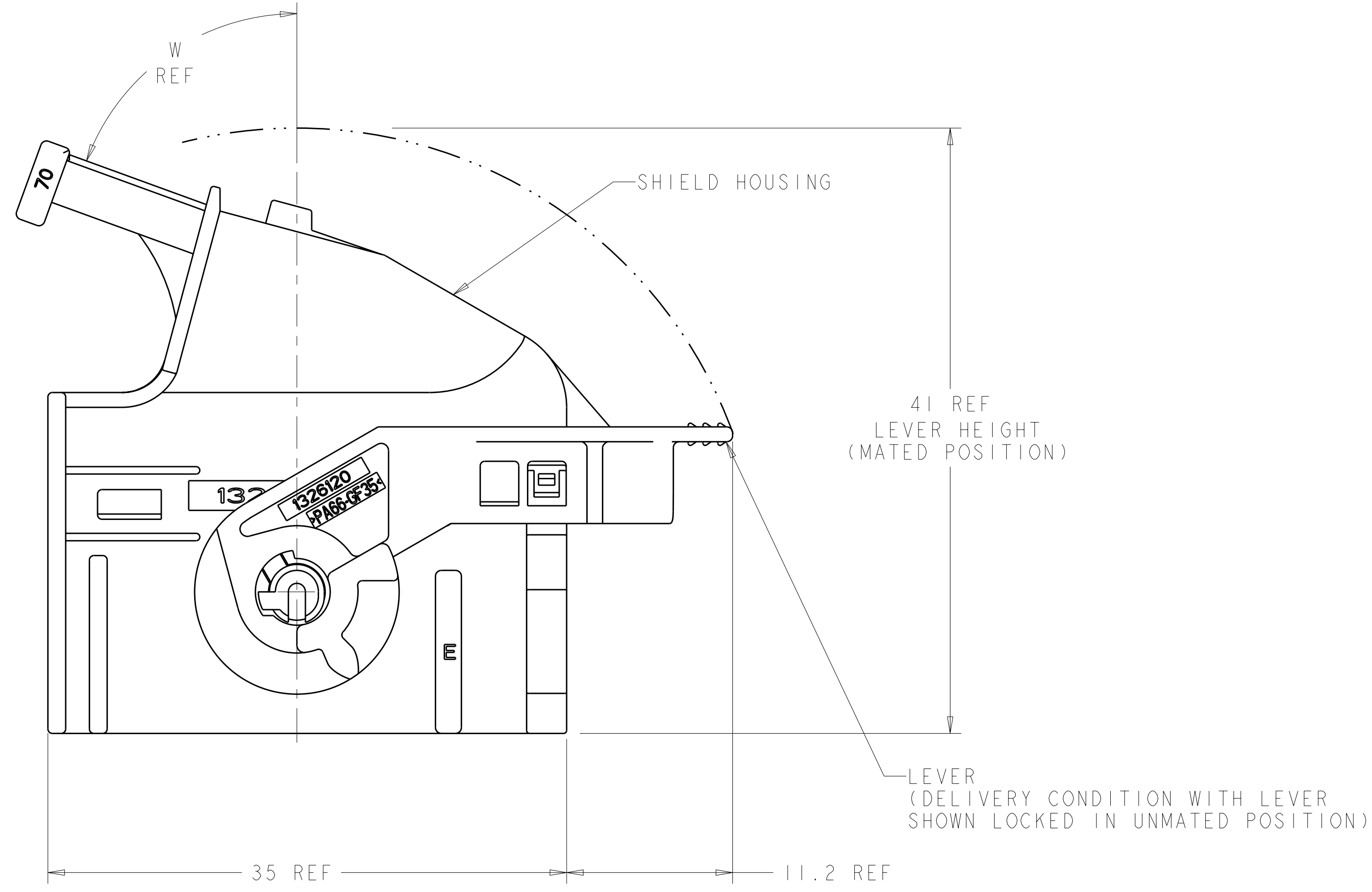
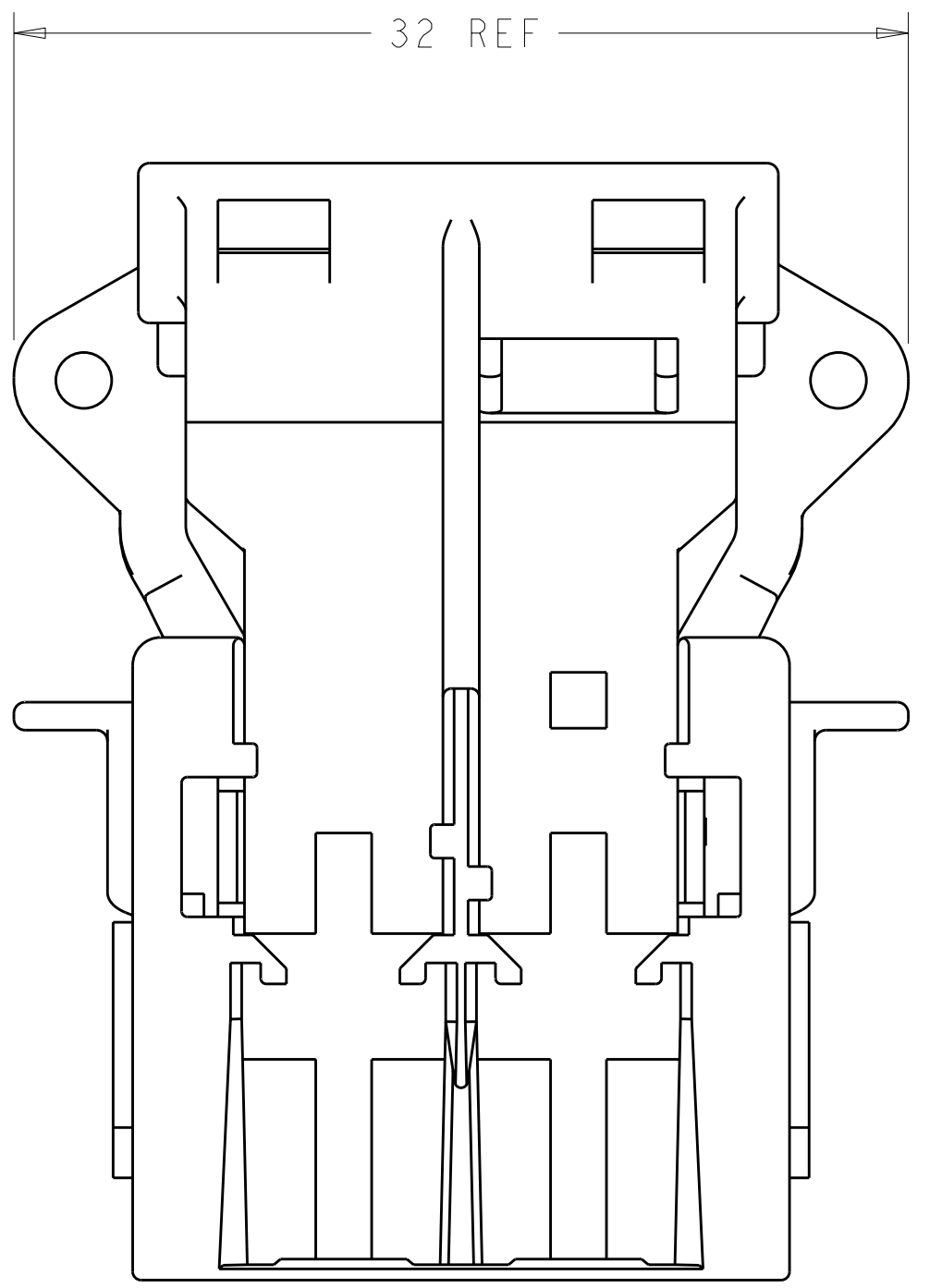

70° WIRE EXIT
SCALE 2:1

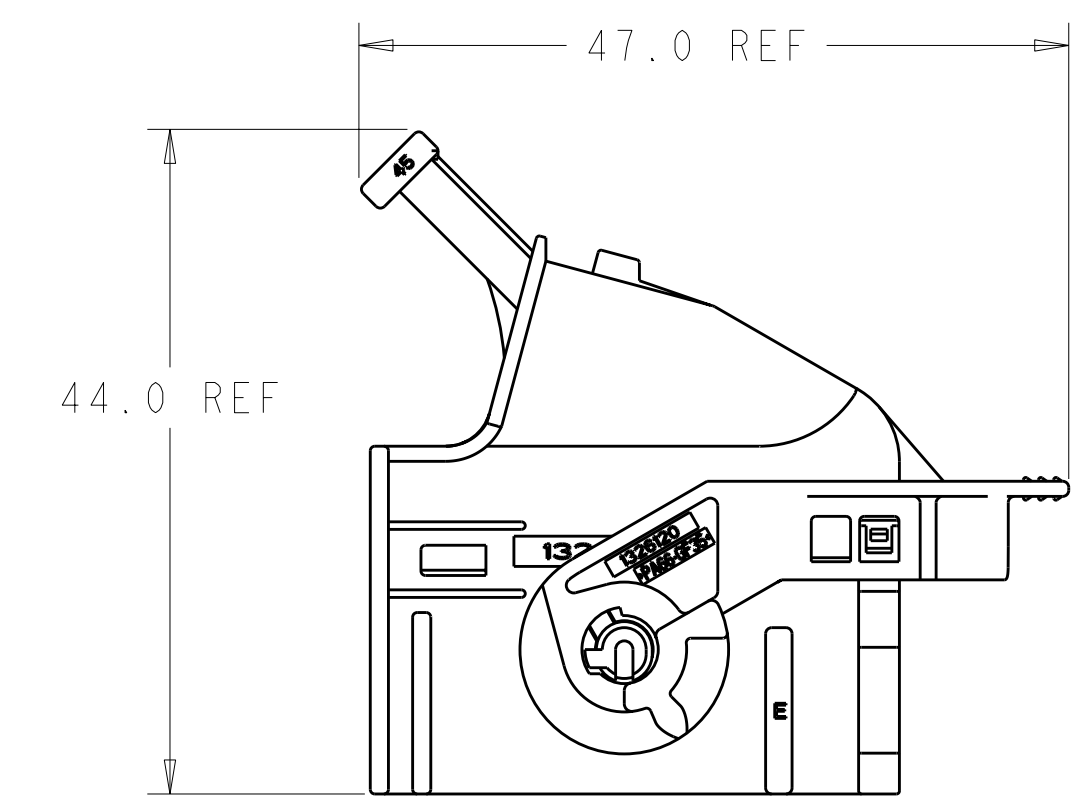

45° WIRE EXIT
SCALE 2:1

DIM W	COLOR	KEYING OPT.	PART NUMBER
45°	BLUE	B-F	1326122-6
45°	GRAY	B-E	1326122-5
45°	BLACK	A-E	1326122-4
70°	BLUE	B-F	1326122-3
70°	GRAY	B-E	1326122-2
70°	BLACK	A-E	1326122-1

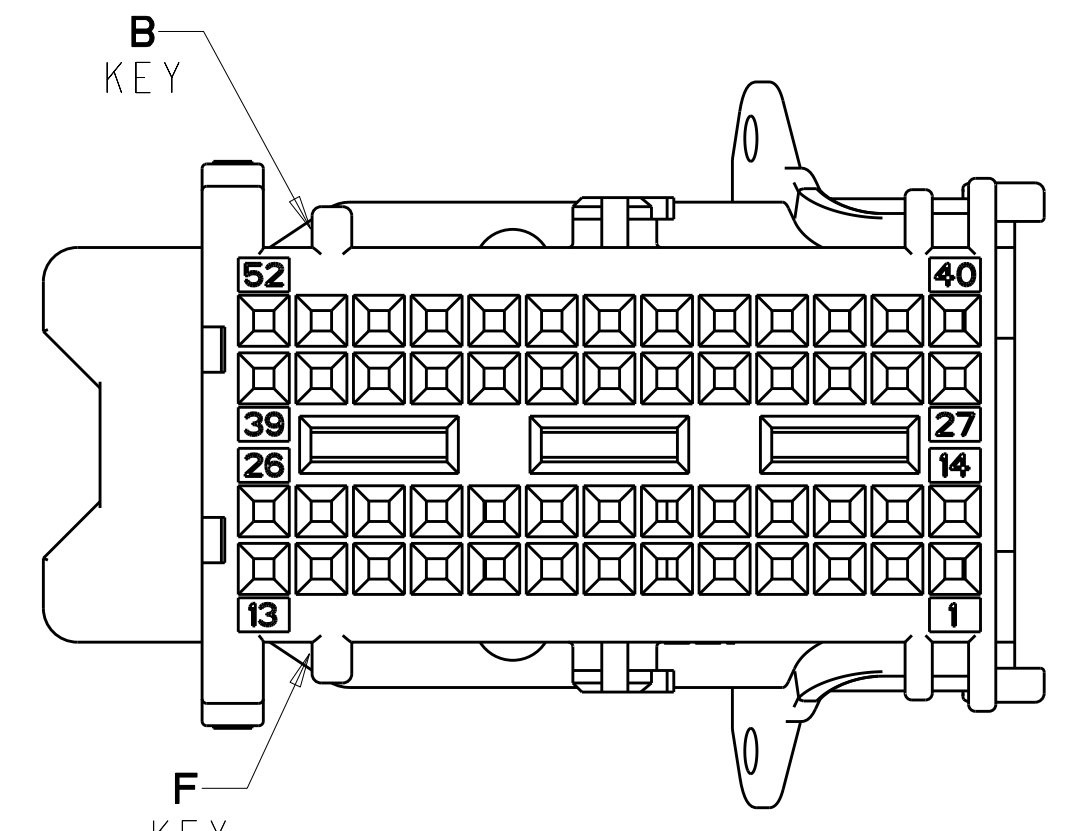

KEY B-F SHOWN FOR
ASSEMBLY 1326122-3
& 1326122-6

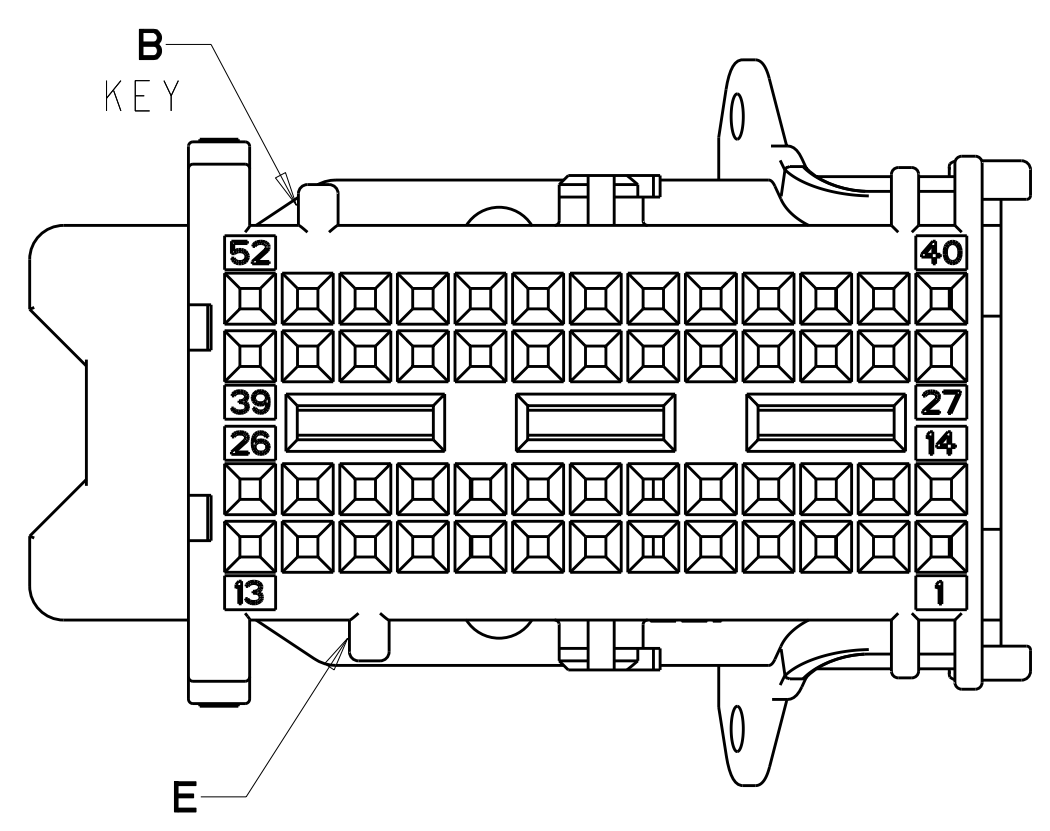

KEY B-E SHOWN FOR
ASSEMBLY 1326122-2
& 1326122-5

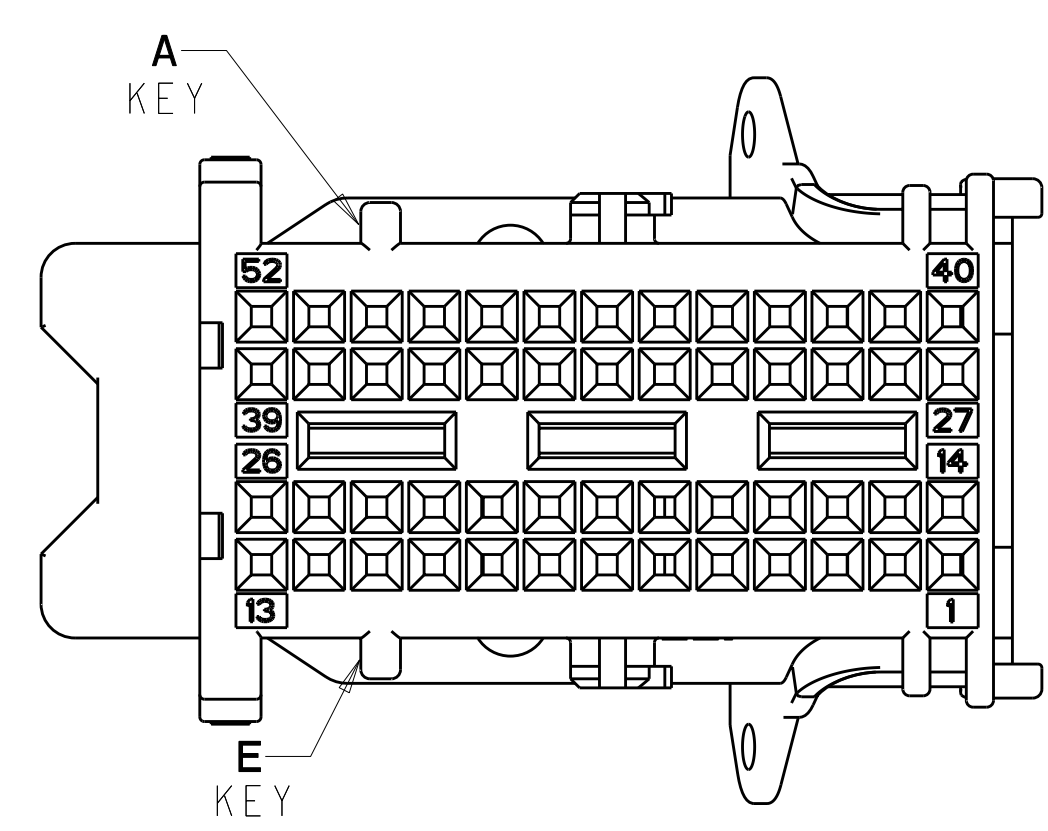

KEY A-E SHOWN FOR
ASSEMBLY 1326122-1
& 1326122-4

DIMENSIONS: mm 		TOLERANCES UNLESS OTHERWISE SPECIFIED: 9 PLC ± 1 PLC ±0.2 5 PLC ±0.05 4 PLC ± ANGLES ± FINISH		DWN T. WOOTEN 07JUL2000 CHK C. MARTIN 07JUL2000 APVD D. KLEIN 07JUL2000 PRODUCT SPEC APPLICATION SPEC WEIGHT CUSTOMER DRAWING		Tyco Electronics Harrisburg, PA 17105-3608 NAME SHIELD ASSEMBLY, 52 POSITION, LEVER ASSISTED CONNECTOR SIZE CAGE CODE DRAWING NO RESTRICTED TO A1 00779 C=1326122 SCALE 4:1 SHEET 1 OF 2 REV B1	
-----------------------	--	---	--	---	--	---	--

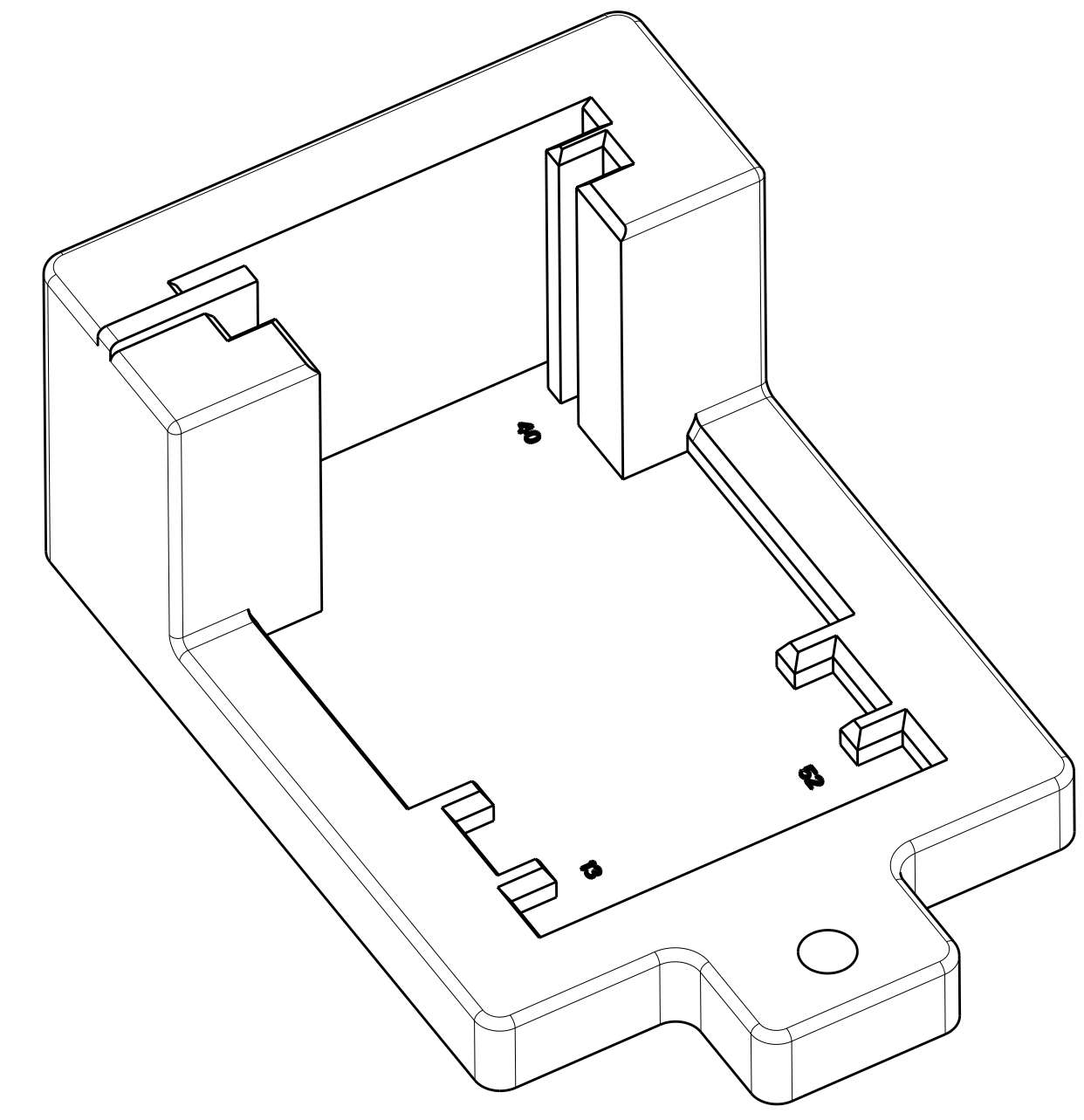
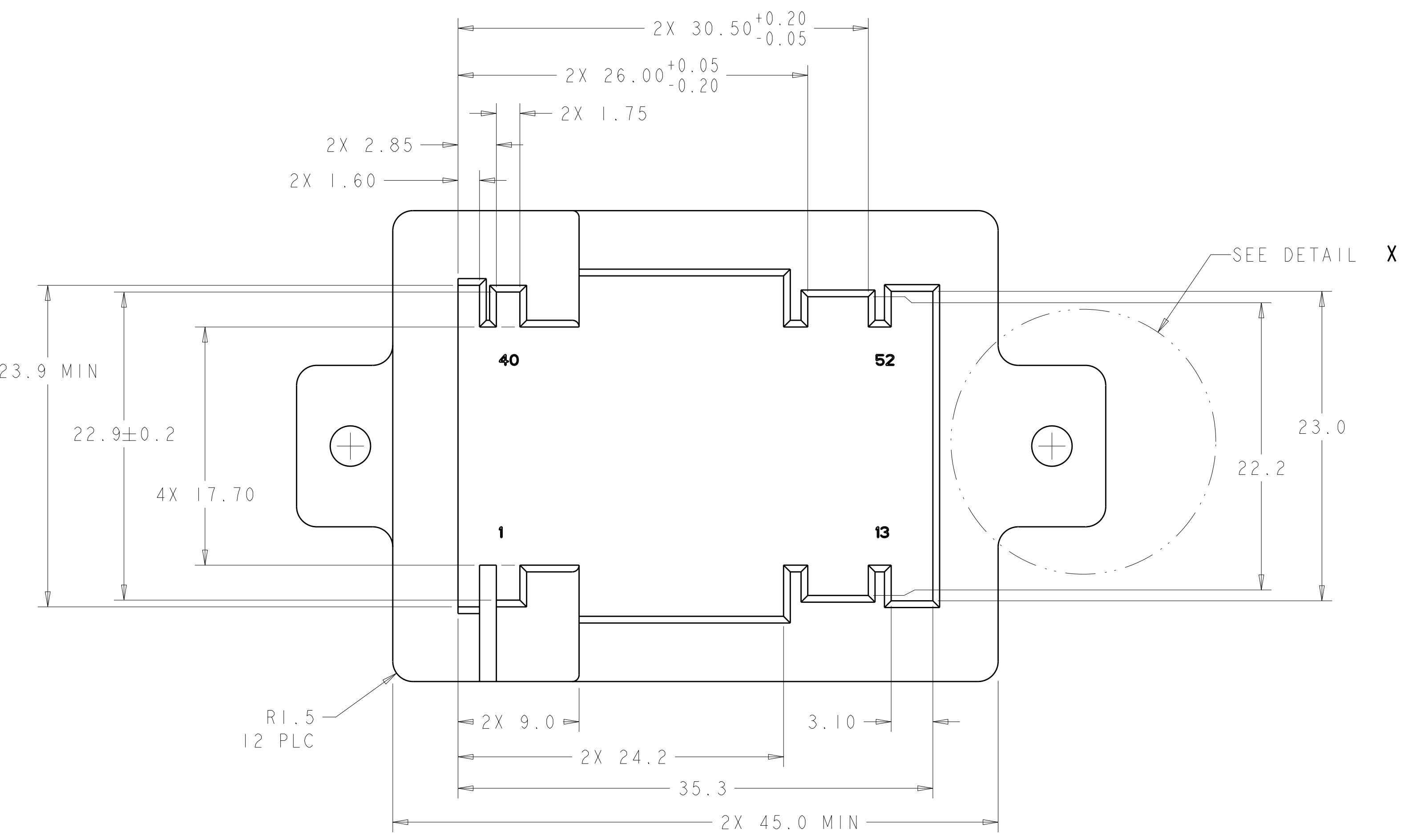

SCALE 3:1

LOC	DIST	REV	DATE	BY	APPD
FX	00				

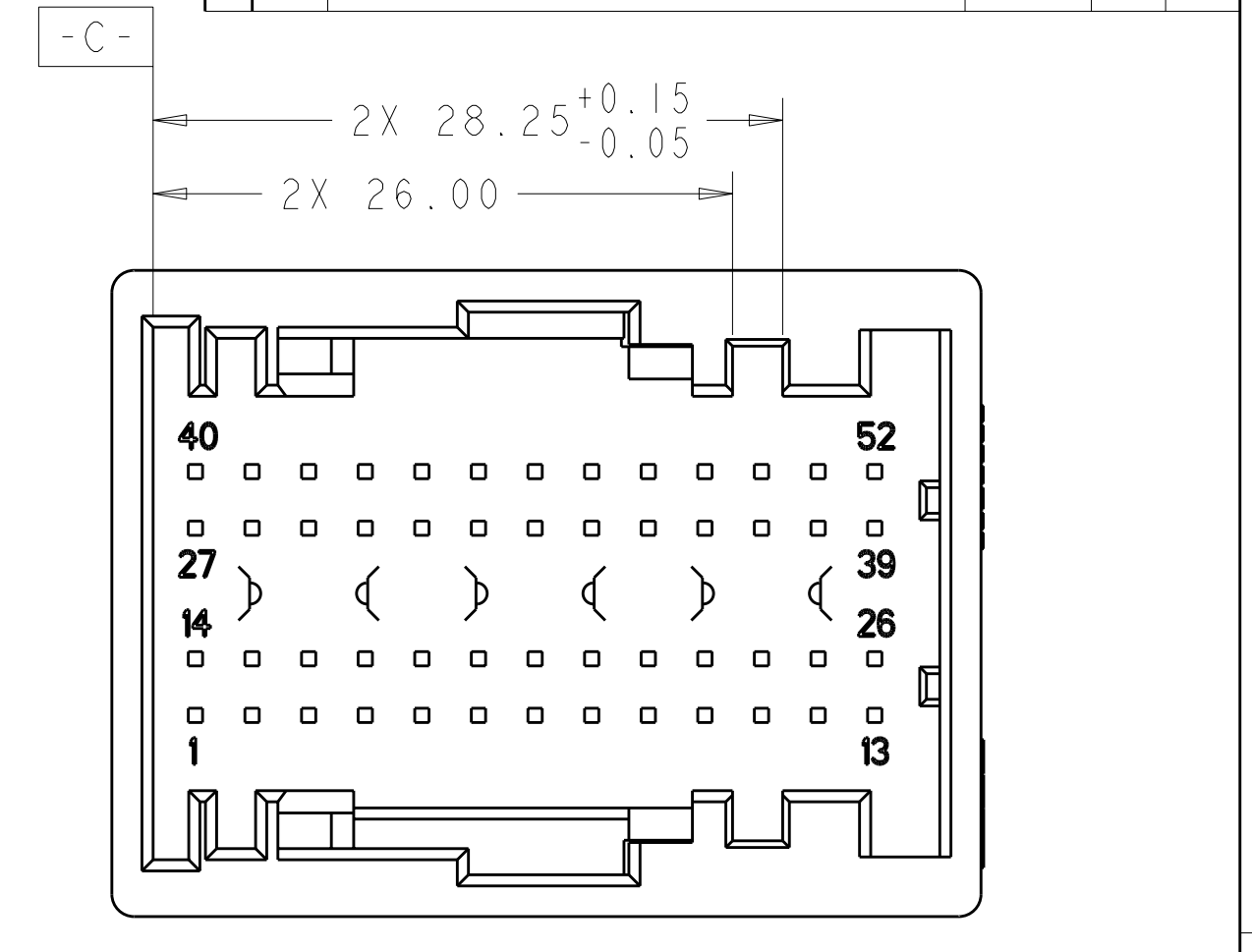

KEY OPTION A-E

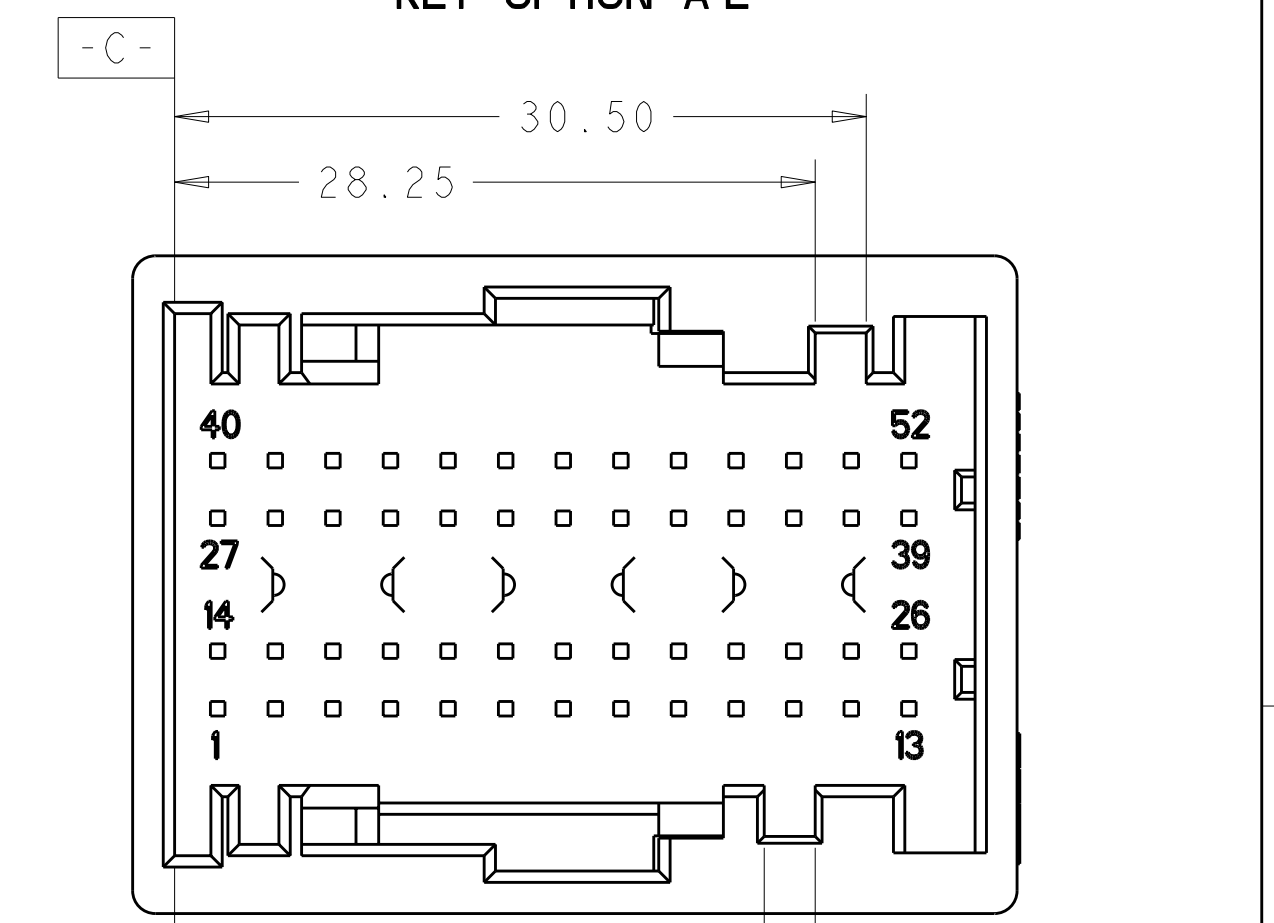

KEY OPTION B-E

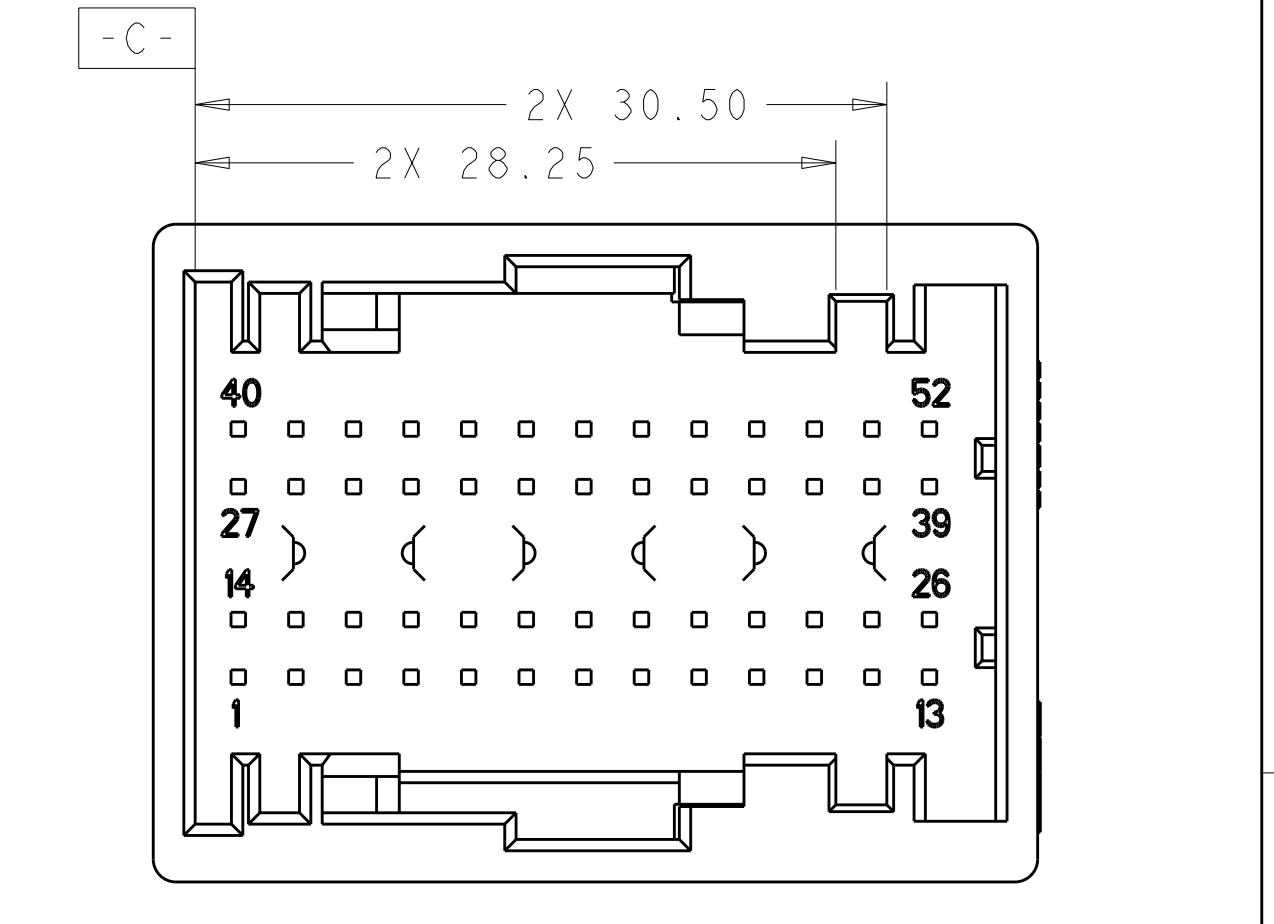

KEY OPTION B-F

KEYING OPTIONS

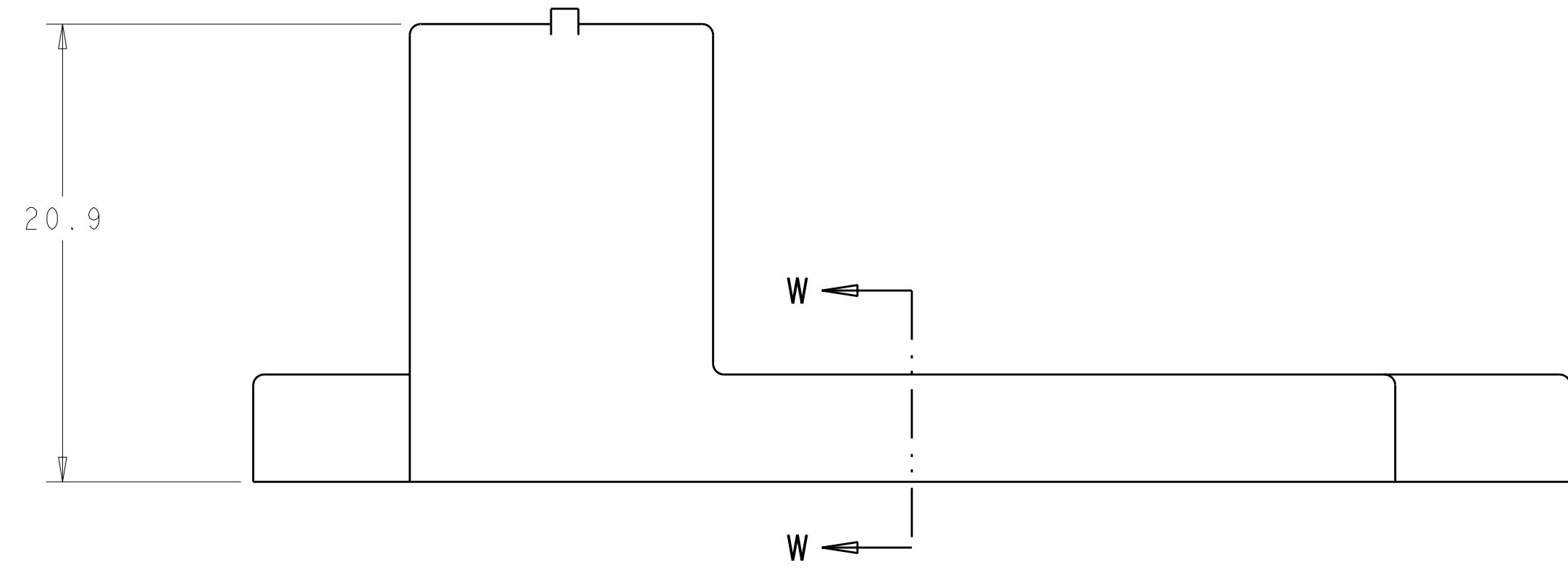

52 POSITION CONNECTOR FIXTURE
 (SHOWN WITH CLEARANCE FOR ALL KEY OPTIONS)

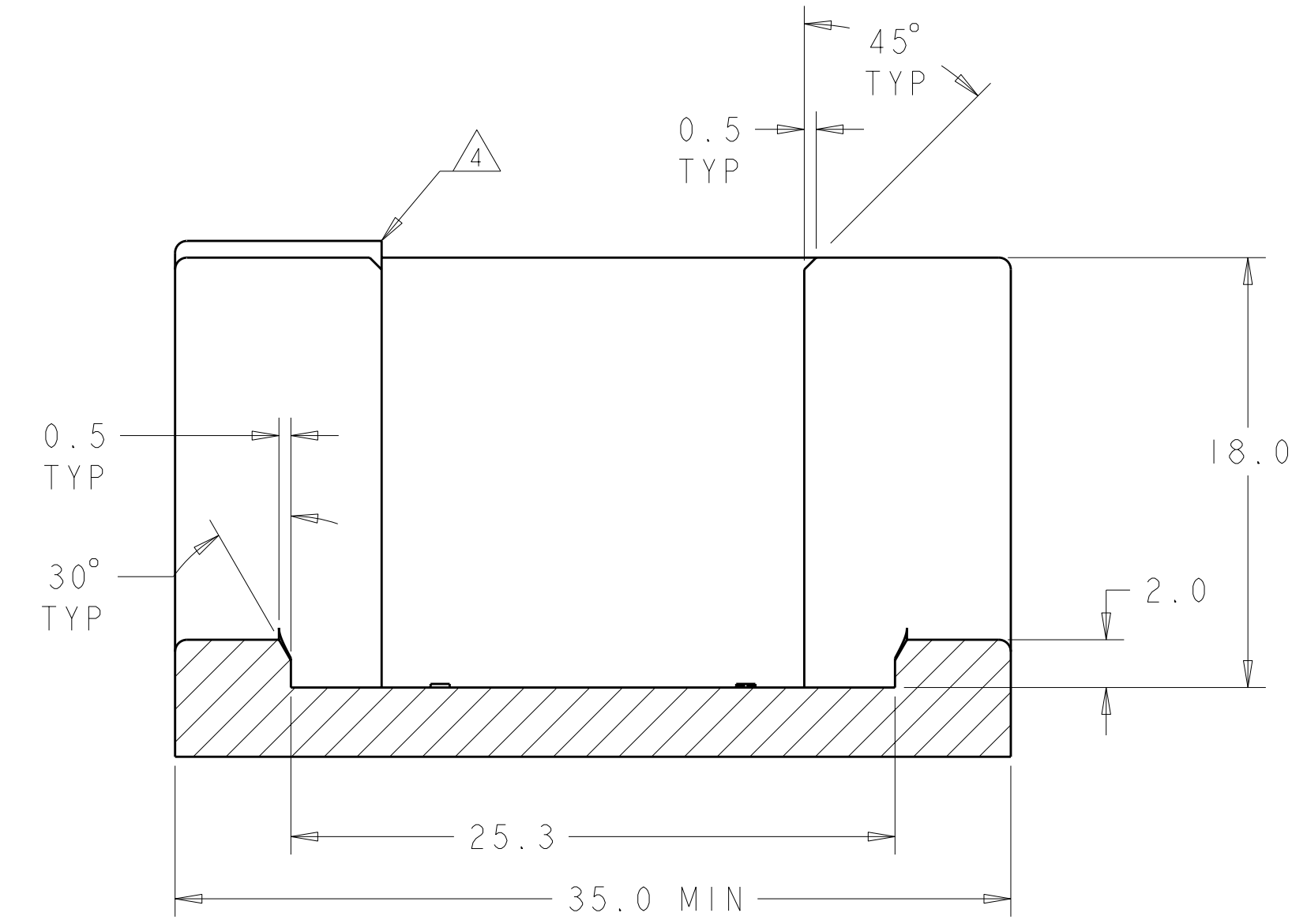

SECTION W-W

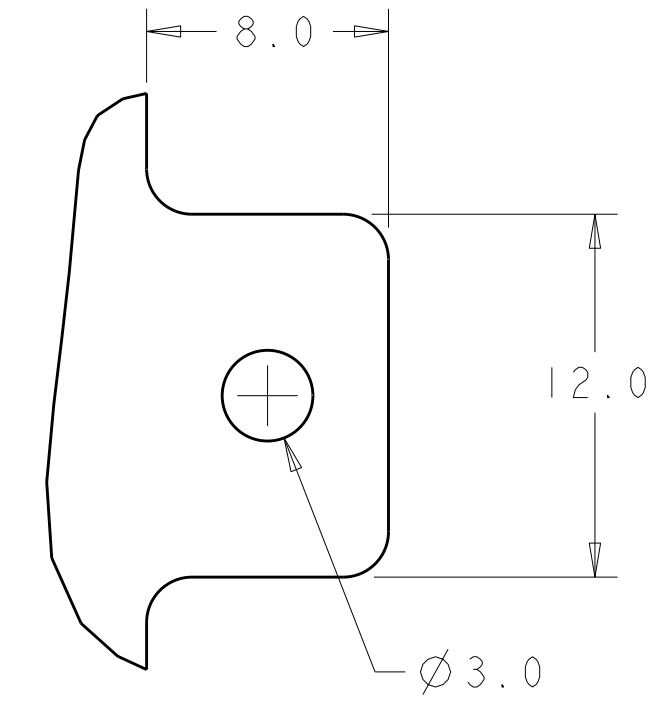

DETAIL X
 SCALE 4:1

- CONNECTOR FIXTURE SHOULD BE USED TO VERIFY THE RECEPTACLE CARRIER IS PROPERLY SEATED AND LOCKED INTO THE SHIELD ASSEMBLY. THE CONNECTOR WILL NOT FULLY MATE TO THE FIXTURE IF THE RECEPTACLE CARRIER IS OUT OF POSITION.
- RECOMMEND USING A SENSING DEVICE FOR VERIFYING FULLY MATED CONNECTORS. SUCH A DEVICE IS AT THE CUSTOMERS DISCUSSION.
- RECOMMENDED MATERIAL: HARDENED STEEL
- NO RADII OR CHAMFER PERMITTED IN SPECIFIED AREA. MUST MAINTAIN 90° EDGE.
- RADII TO BE 0.5 UNLESS OTHERWISE SPECIFIED.
- OPTIONAL CONSTRAINT FEATURE.

DIMENSIONS: mm TOLERANCES UNLESS OTHERWISE SPECIFIED: 9 PLC ± 1 PLC ±0.2 5 PLC ±0.05 4 PLC ± ANGLES ± FINISH ±1*		DWN T. WOOTEN 07JUL2000 CHK C. MARTIN 07JUL2000 APVD D. KLEIN 07JUL2000	Tyco Electronics Harrisburg, PA 17105-3608
MATERIAL: Δ		NAME: SHIELD ASSEMBLY, 52 POSITION, LEVER ASSISTED CONNECTOR	SIZE: CAGE CODE DRAWING NO: A11 00779 C=1326122
CUSTOMER DRAWING		SCALE: 4:1	SHEET 2 OF 2 REV B1

单击下面可查看定价，库存，交付和生命周期等信息

[>>TE Connectivity\(泰科\)](#)