

LOC	DIST	REVISIONS					
GP	00	P	LTN	DESCRIPTION	DATE	DMN	APVD
		A		RELEASED PER ECO-12-013192	18OCT2012	BMM	MRS
		B		RELEASED PER ECO-19-008848	10JUN2019	ES	SH
		B1		REVISED PER ECO-19-014965	08OCT2019	IT	SH

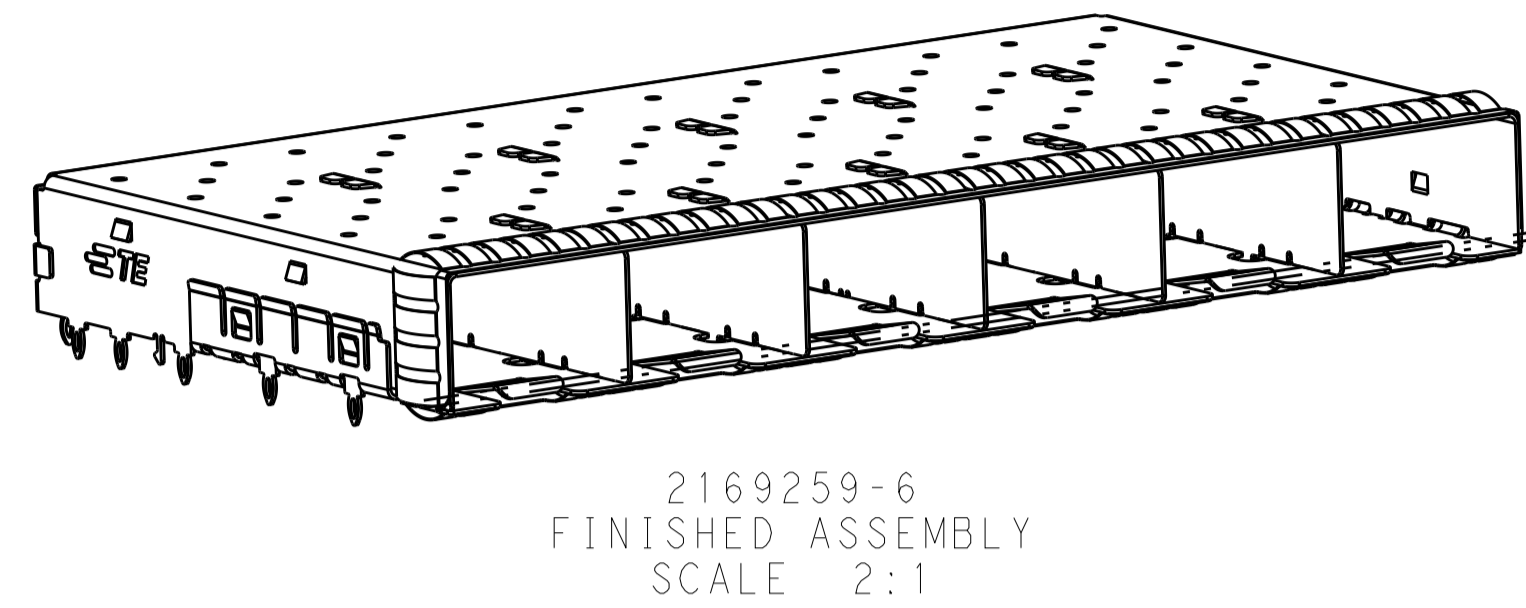

- 1. MATERIAL: 0.25mm THICK NICKEL SILVER ALLOY.
EMI SPRINGS: COPPER ALLOY.
- 2. FINISH:
SPRINGS: MINIMUM OF 0.8um TIN PLATE OVER A MINIMUM OF 0.8um NICKEL UNDERPLATE.
NON-PLATED EDGES PERMISSIBLE.
- 3. MATES WITH SFP MSA COMPLIANT TRANSCEIVERS.
- 4. PADS AND VIAS CHASSIS GROUND.
- 5. INTERPRETATION OF DATUM REFERENCE FRAME IN ACCORDANCE WITH SECT 4.4.1.1 OF ASME Y14.5M-1994.
- 6. MINIMUM PC BOARD THICKNESS:
SINGLE SIDED = 1.50mm
DOUBLE SIDED = 2.25mm
- 7. HOLE PATTERN REPEATS FOR EACH PORT. SPACING BETWEEN PORTS IS 14.25mm.
- 8. DATUM AND BASIC DIMENSION ESTABLISHED BY CUSTOMER.
- 9. REFERENCE APPLICATION SPEC. 114-13120, HOLE A, FOR RECOMMENDED DRILL HOLE DIAMETER AND PLATING THICKNESS.
- 10. REFERENCE APPLICATION SPEC. 114-13120, HOLE B, FOR RECOMMENDED DRILL HOLE DIAMETER AND PLATING THICKNESS.
- 11. CERTAIN MATING TRANCEIVERS MAY REQUIRE ADDITIONAL PCB THICKNESS THAT WOULD BE DETERMINED BY THE CUSTOMER.
- 12. PRODUCT COMPLIES WITH SPECIFICATION SFF-8433 IMPROVED PLUGGABLE FORM FACTOR FOR SFP+ GANGED CAGES.
- 13. CUSTOMIZED PART: INCREASED WELDING POINTS QUANTITY FOR EMI SPRING WELDING.

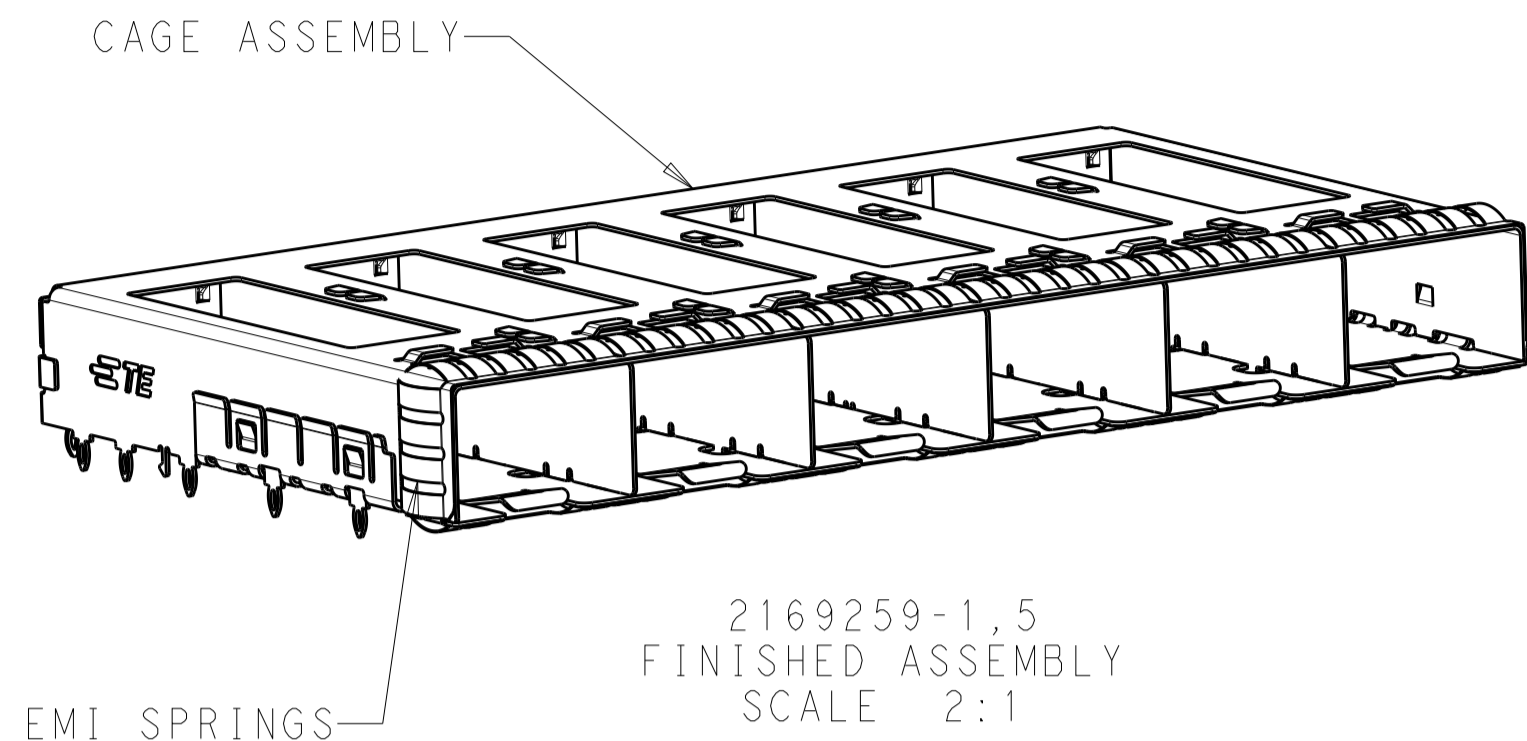
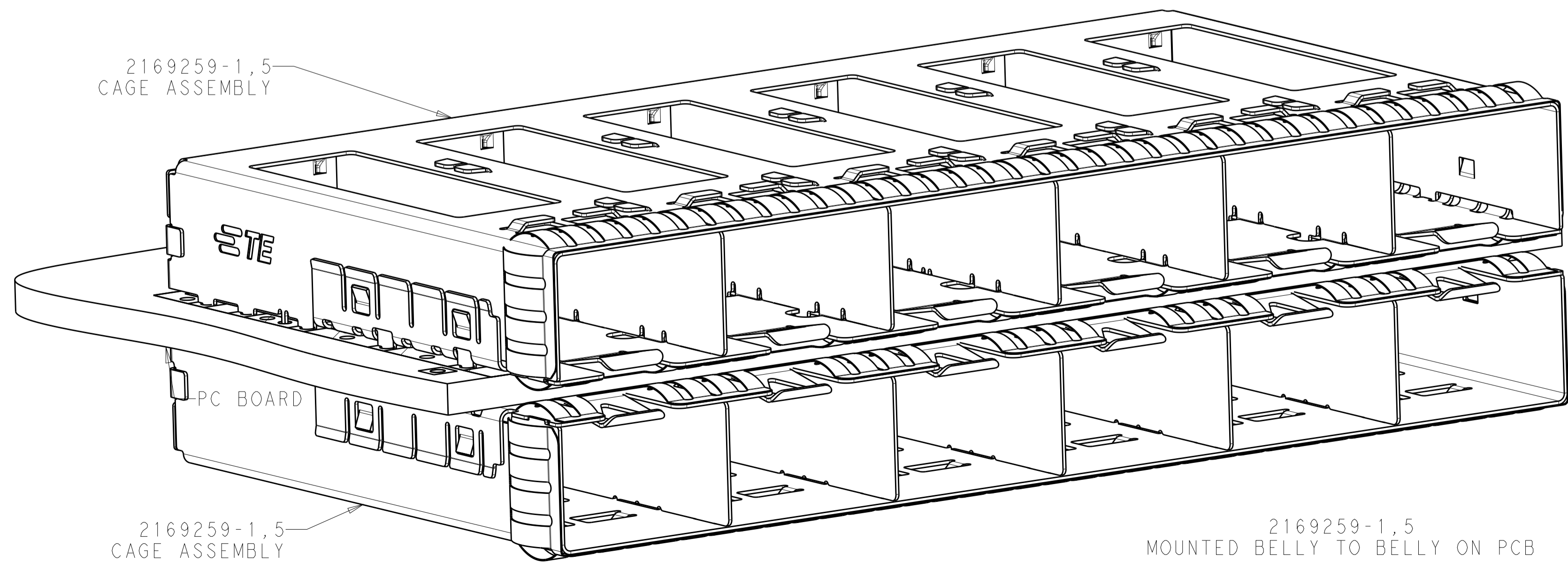
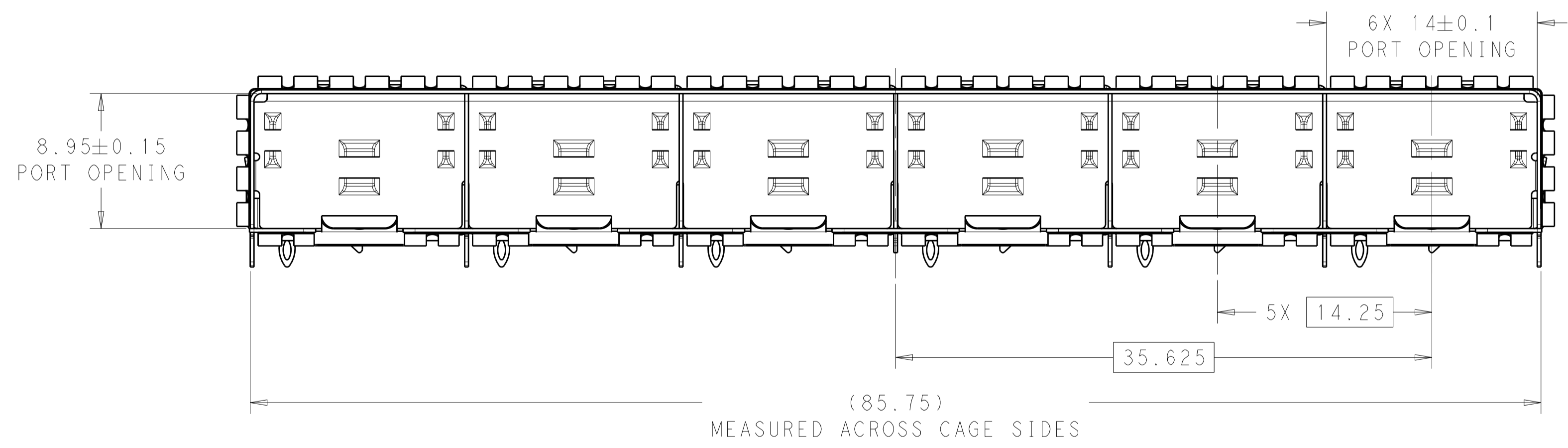
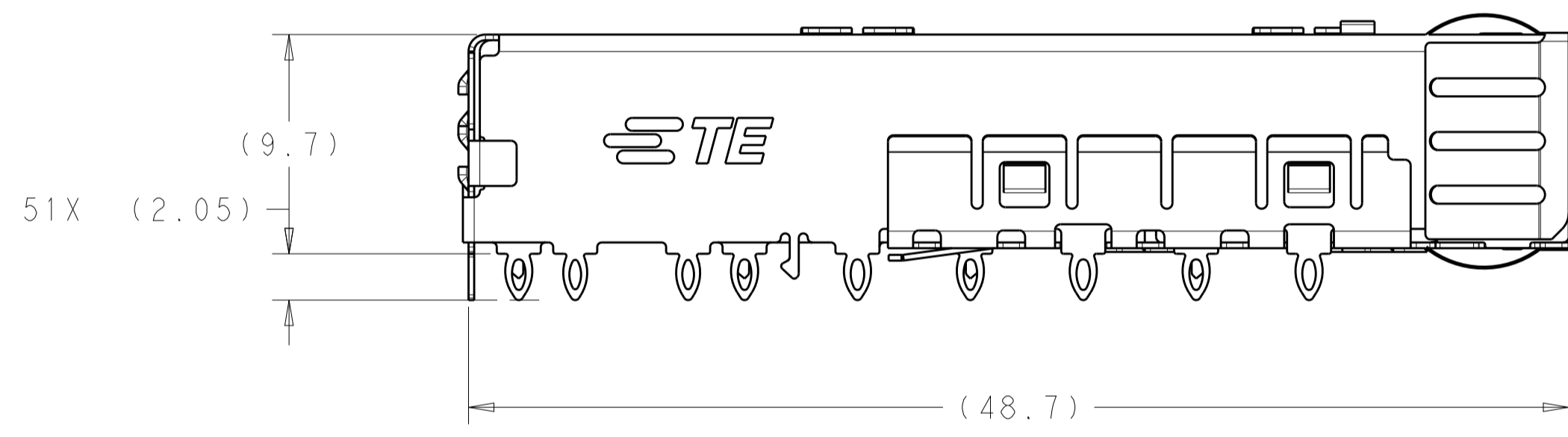

2169259-6
2169259-5
2169259-1
PART NUMBER

THIS DRAWING IS A CONTROLLED DOCUMENT.		DMN: ERIC_SHI 10JUN2019	TE Connectivity
DIMENSIONS: mm		CHK: SEAN_HAN 10JUN2019	
TOLERANCES UNLESS OTHERWISE SPECIFIED:		APVD: SEAN_HAN 10JUN2019	NAME: SFP+ ENHANCED 1X6 CAGE SUBASSEMBLY PRESS FIT, EXTERNAL EMI SPRINGS
0 PLC ±0.1		PRODUCT SPEC: 108-2364	
1 PLC ±0.1		APPLICATION SPEC: 114-13120	SIZE: CAGE CODE DRAWING NO: A100779C=2169259
2 PLC ±0.1		WEIGHT: -	RESTRICTED TO: -
3 PLC ±0.1		CUSTOMER DRAWING	SCALE: 4:1 SHEET 1 OF 4 REV: B1
4 PLC ±0.1			
ANGLES ±0.1			
FINISH: *			

LOC		DIST		REVISIONS			
GP	00	P	LTN	DESCRIPTION	DATE	OWN	APVD
-	-	-	-	SEE SHEET 1	-	-	-

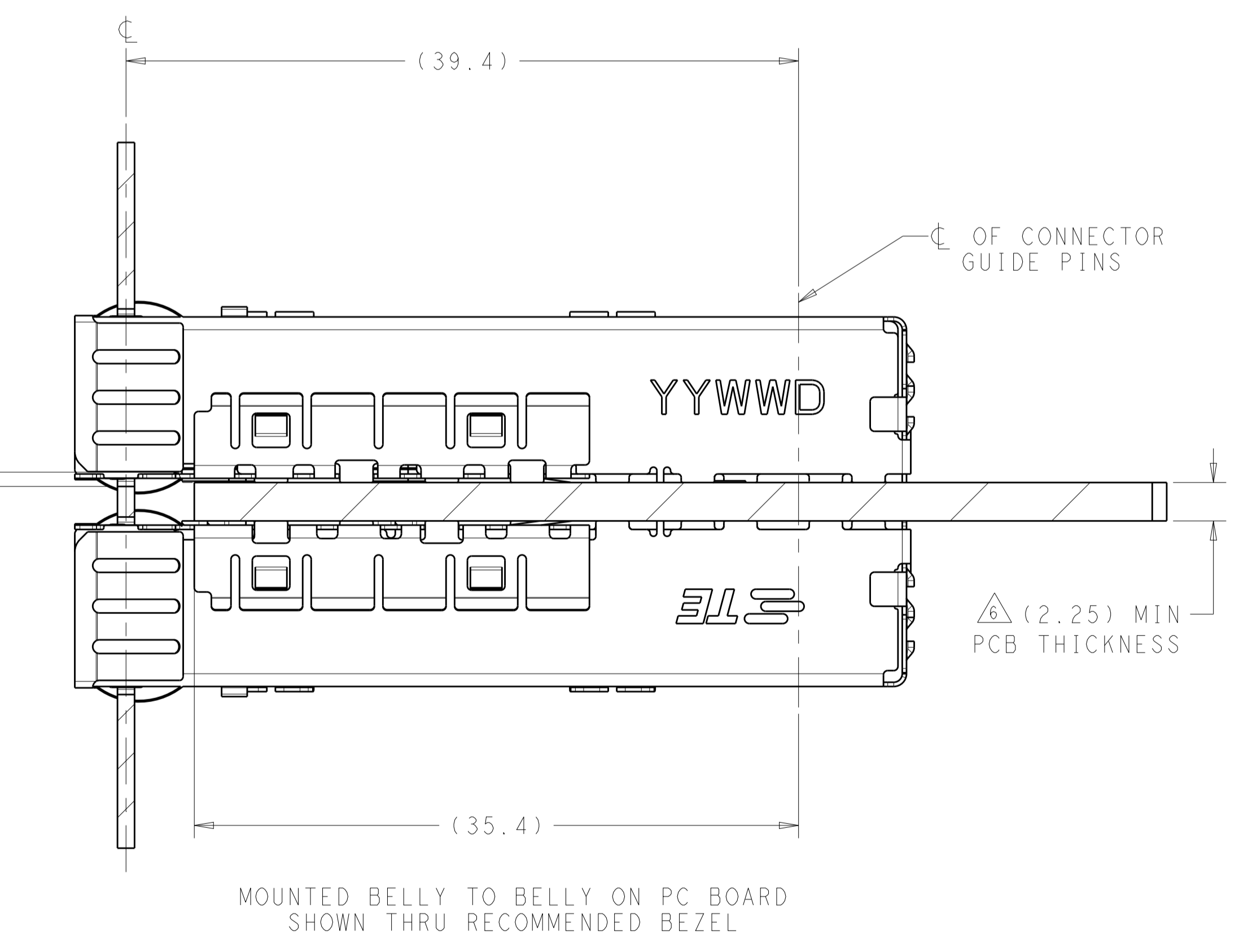
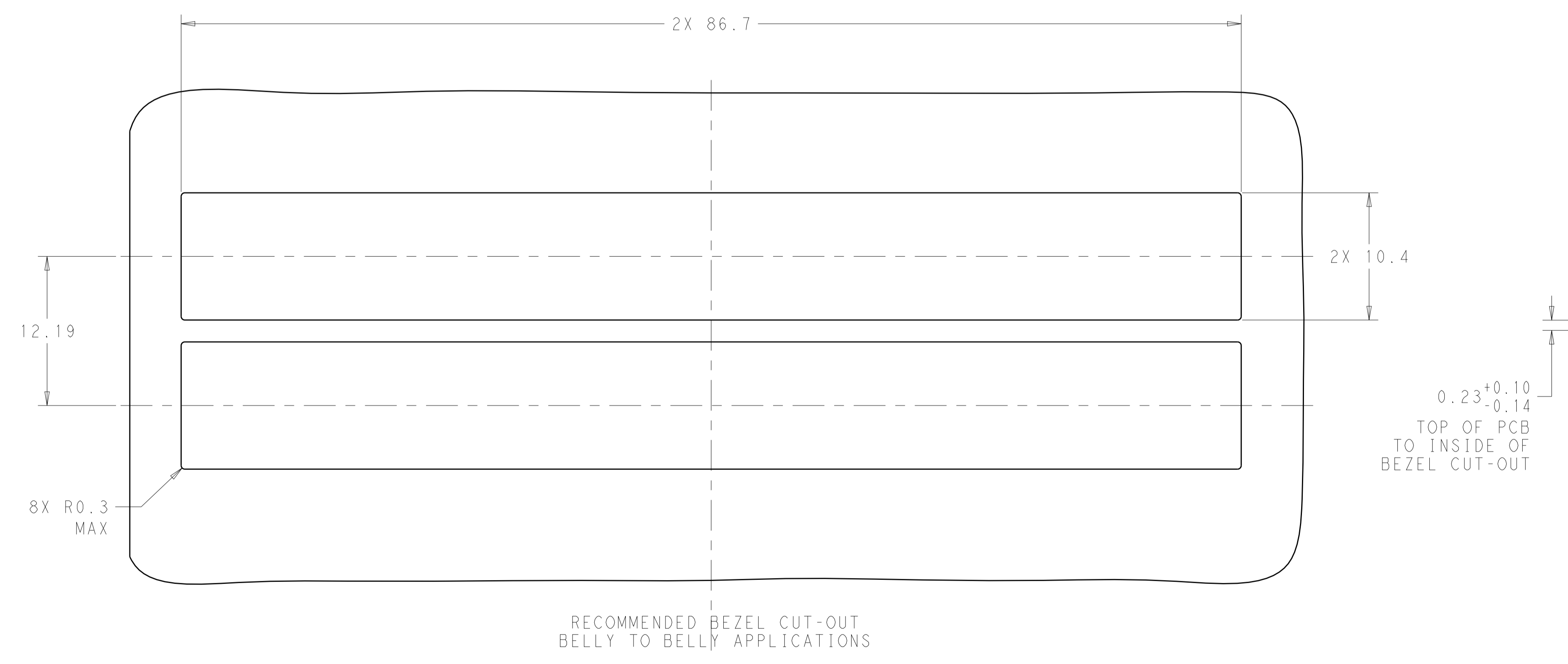
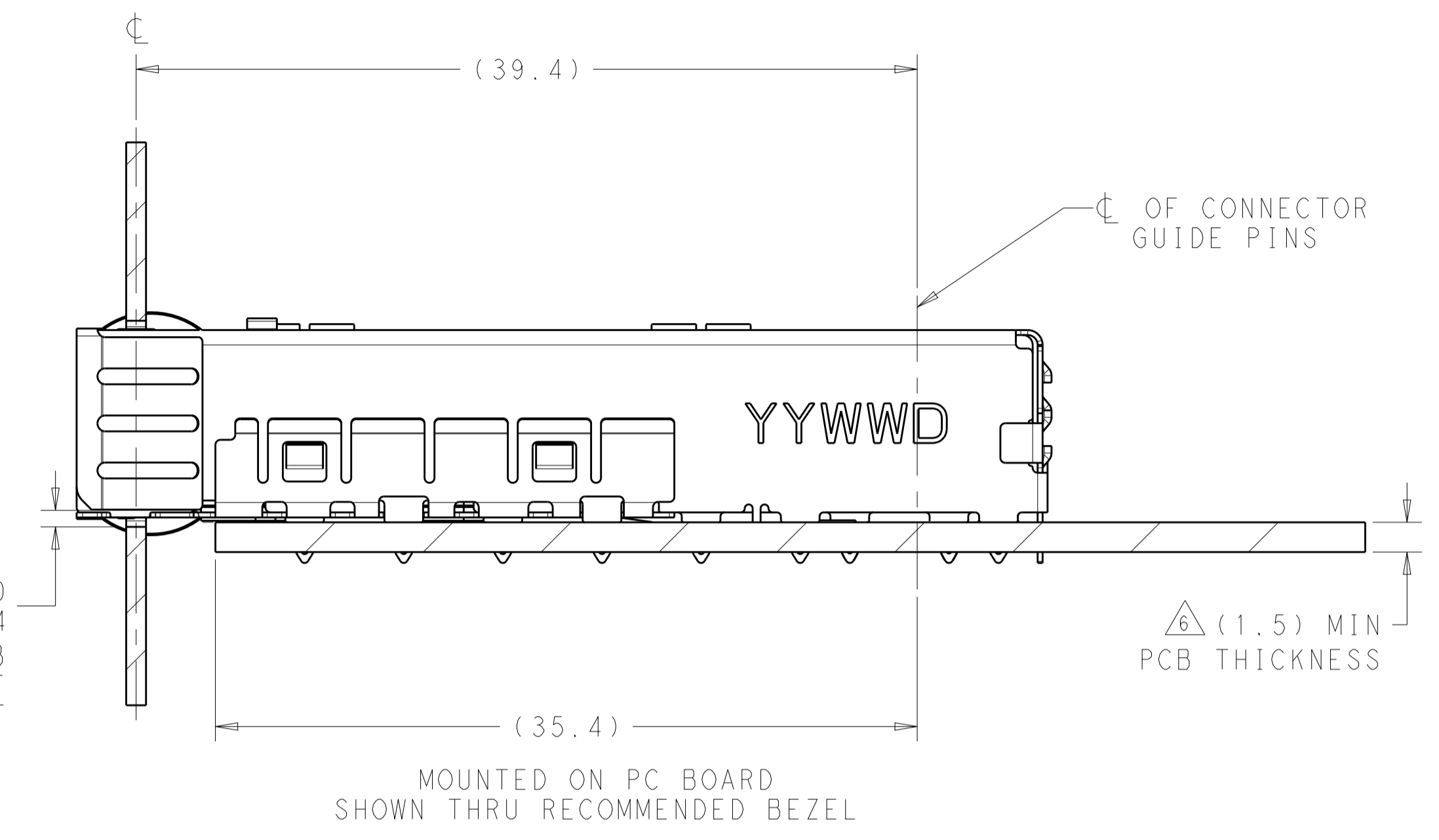
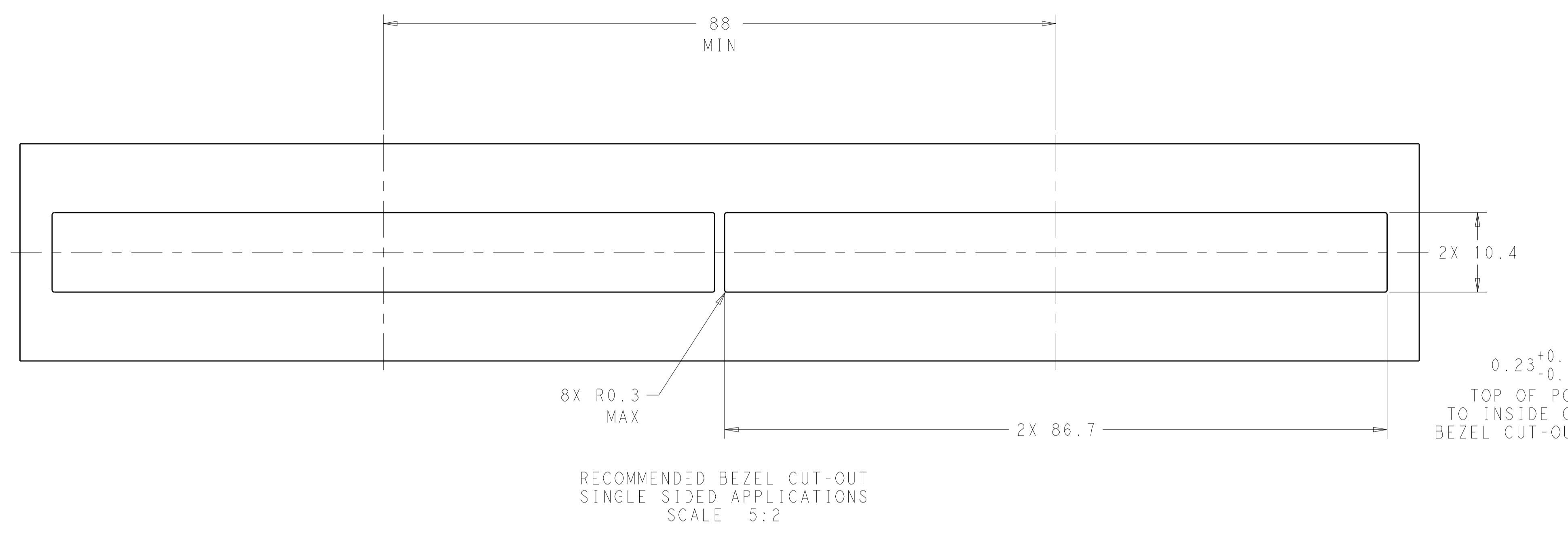

THIS DRAWING IS A CONTROLLED DOCUMENT.		OWN: ERIC SHI 10JUN2019	TE Connectivity
DIMENSIONS: mm		CHK: SEAN HAN 10JUN2019	
TOLERANCES UNLESS OTHERWISE SPECIFIED:		APVD: SEAN HAN 10JUN2019	NAME: SFP+ ENHANCED 1X6 CAGE SUBASSEMBLY PRESS FIT, EXTERNAL EMI SPRINGS
0 PLC ±0.1		PRODUCT SPEC	
1 PLC ±0.1		108-2364	SIZE: CAGE CODE DRAWING NO RESTRICTED TO
2 PLC ±0.1		APPLICATION SPEC	
3 PLC ±0.1		114-13120	A100779C=2169259
4 PLC ±0.1		WEIGHT	
ANGLES ±1°		CUSTOMER DRAWING	SCALE 4:1 SHEET 2 OF 4 REV B1

单击下面可查看定价，库存，交付和生命周期等信息

[>>TE Connectivity\(泰科\)](#)