

**NOTES:**

1. MARKED WITH TE PART NUMBER, TE (HASTINGS) CAGE CODE, DATE CODE AND REAR CONTACT LOCATION MARKING WHERE SHOWN. SEE SHEET 2 FOR TEXT AND POSITION. THE PART MARKING POSITION WILL CHANGE DEPENDING ON SHELL KEYING.

PART NUMBER EXAMPLE: D369 - MR 3 3 - N S 1

BASIC PART No. \_\_\_\_\_  
 SHELL STYLE (MR = INLINE METALLIZED RECEPTACLE)  
 SHELL SIZE \_\_\_\_\_  
 CONTACT QTY (3 = 3 x #22's)

CONTACT CONFIGURATION (P = PIN, S = SKT)  
 SHELL KEYING

2. PERFORMANCE:  
 TEMPERATURE RANGE : -55°C TO +175°C. INSULATION RESISTANCE : ≥5000 MΩ.  
 DIELECTRIC WITHSTAND: 1500VRMS, <2mA. SEALING: 18KM(60000FT) ALTITUDE / IP67  
 DURABILITY : 500 MATING CYCLES MIN. FLUID RESISTANCE: I.A.W. EN2591-315.  
 FLAMMABILITY, SMOKE AND TOXICITY: I.A.W. FAR 25.853 APPENDIX F.

3. INSERTION/EXTRACTION TOOL (M81969/14-01 OR EQUIVALENT) SUPPLIED SEPARATELY.

Contact Configuration	Contact Description	Contact P/N (OR EQUIVALENT)		Crimp Positioner		Crimp Tool	Wire Accommodation	Current Rating
		Pin	Socket	Pin	Socket			
0		NO CONTACTS SUPPLIED						
1	CRIMP, COPPER WIRE	38941-22L	38946-22L	M22520/2-09	M22520/2-06	M22520/2-01	22-26 AWG	5A (22 AWG)
2	CRIMP, ALUMINIUM WIRE	200-1042-22	200-1142-22	KAL2		ALNP 22-A	22 AWG	5A
3	CRIMP, COPPER WIRE (ENLARGED WIRE)	182-0860-22	182-0862-22	M22520/2-09	M22520/2-06	M22520/2-01	20-24 AWG	7.5A (20 AWG)**

\*\* UPPER TEMPERATURE LIMIT DE-RATED TO +133°C AT 7.5A (20 AWG)

5. MATERIALS & FINISHES:

COMPONENT	MATERIAL	FINISH
SEALS	SILICONE / FLUOROSILICONE BLEND RUBBER PER AMS-R-25988 TYPE II, CLASS I, GRADE 40	N/A
INSERT COMPONENTS	POLYETHERIMIDE, 10% GLASS FILLED PER ASTM D 5205 or POLYETHERETHERKETONE 450G	N/A
SHELL BODY	POLYETHERIMIDE, 10% GLASS FILLED PER ASTM D 5205	ELECTROLESS NICKEL PLATED

NICKEL PLATED FINISH MAY VARY IN COSMETIC APPEARANCE. PLATING MAY BE DULL IN APPEARANCE WITH A ROUGH SURFACE, OR SHINY IN APPEARANCE WITH A SMOOTH SURFACE. THIS IN NO WAY AFFECTS THE FORM, FIT OR FUNCTION OF THE PRODUCT, OR THE ENVIRONMENTAL PERFORMANCE OF THE PLATED FINISH. IT SHOULD BE CONSIDERED A VISUAL VARIATION ONLY.

6. MAXIMUM WEIGHT (WITHOUT CONTACTS): 2.5g (PIN INSERT), 2.5 (SKT INSERT).

7. EMI SHIELDING PERFORMANCE (MATED PAIR):

FREQUENCY (MHz)	150	200	300	400	800	1000	1500	2000	3000	4000	6000	10000
ATTENUATION (dB)	65	60	55	55	45	43	40	37	35	33	30	20

8. CONNECTORS MARKED WITH DATE CODE H1841D OR THEREAFTER WILL COMPRISE A BONDED INSERT ASSEMBLY.

9 'OPEN' INDICATOR MAY OR MAY NOT BE PRESENT.

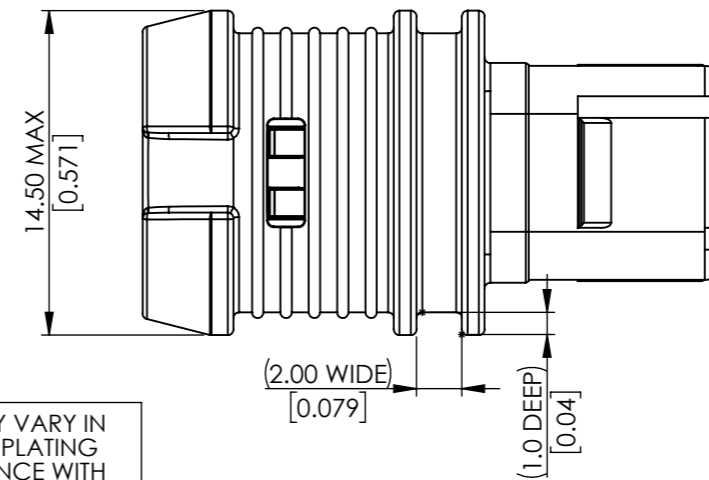
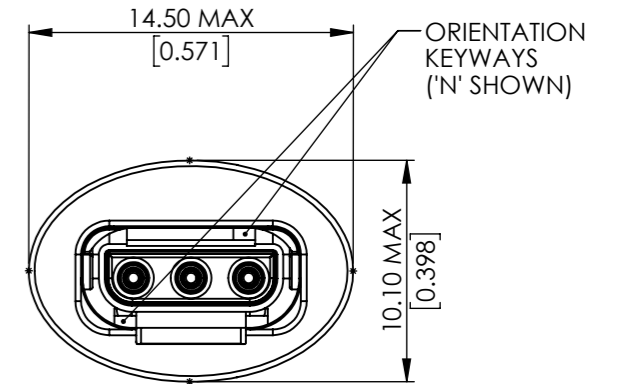
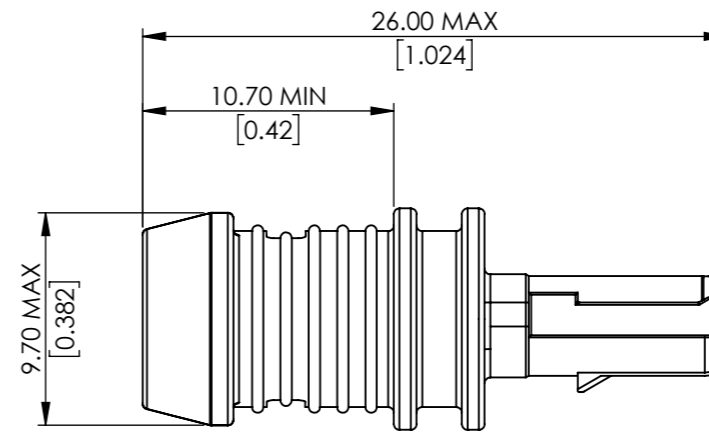

SHELL KEYING	
ORIENTATION	COLOUR CODING BAND
N	BLACK
A	DARK RED
B	DARK BLUE
C	DARK GREEN
D	YELLOW

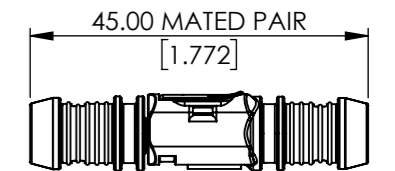

SCALE 1:1

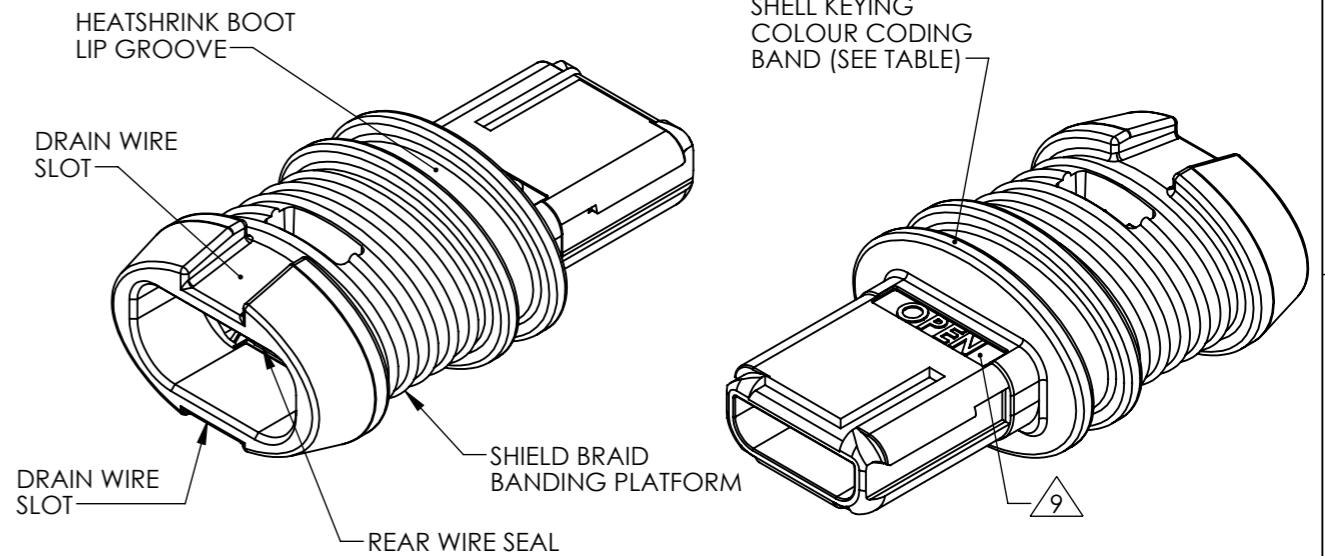

THE CONNECTOR DESCRIBED ON THIS DRAWING SHALL MEET THE QUALIFICATION REQUIREMENTS AS OUTLINED IN TE QTP 109-163002

BS8888 THIRD ANGLE PROJECTION	MATERIAL: <b>SEE NOTE 5</b>	FINISH: <b>SEE NOTE 5</b>		
UNLESS OTHERWISE STATED: DIMENSIONS: mm [INCHES]	TITLE: <b>SHIELDED D369 RECEPTACLE SHELL SIZE 3, 3 WAY</b>		TYPE: CUSTOMER DRAWING	
IF IN DOUBT, ASK	SIZE: <b>A3</b>	SCALE: <b>3:1</b>	DRAWING NUMBER: <b>612082-3-ENV</b>	SHEET: <b>1 OF 2</b> ISSUE: <b>AG</b>

AG	DUK-71928	JCB	JP	RJM	CEO	03/09/2020
ISSUE	CHANGE NOTE	DRAWN	CHECKED	APP. ENG.	APP. MARKETING	DATE

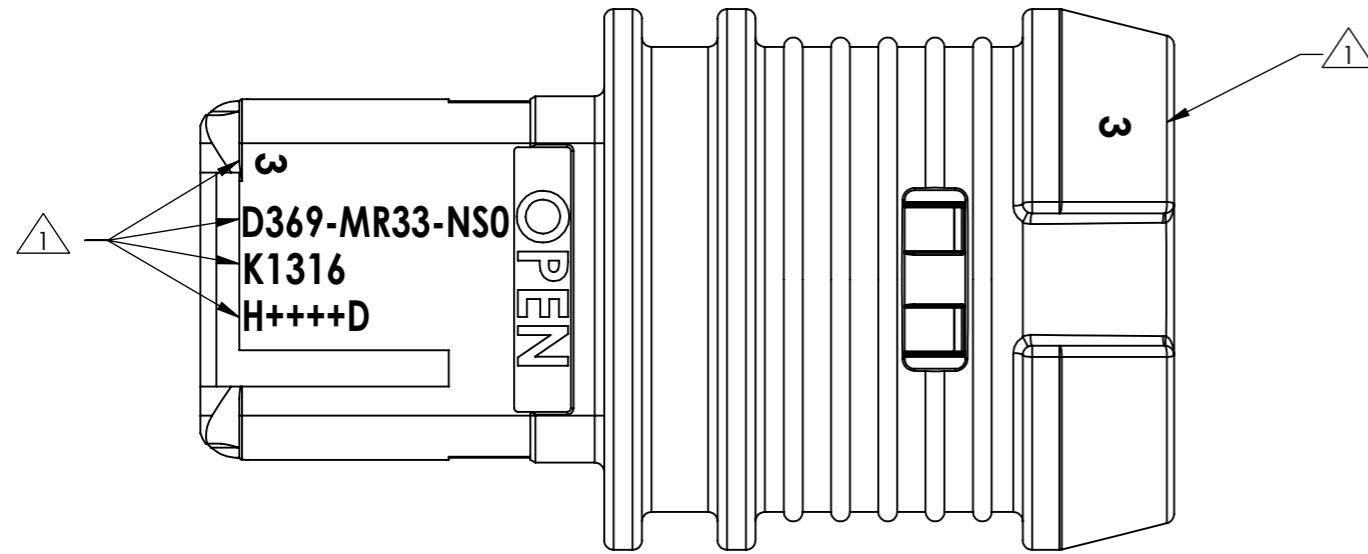

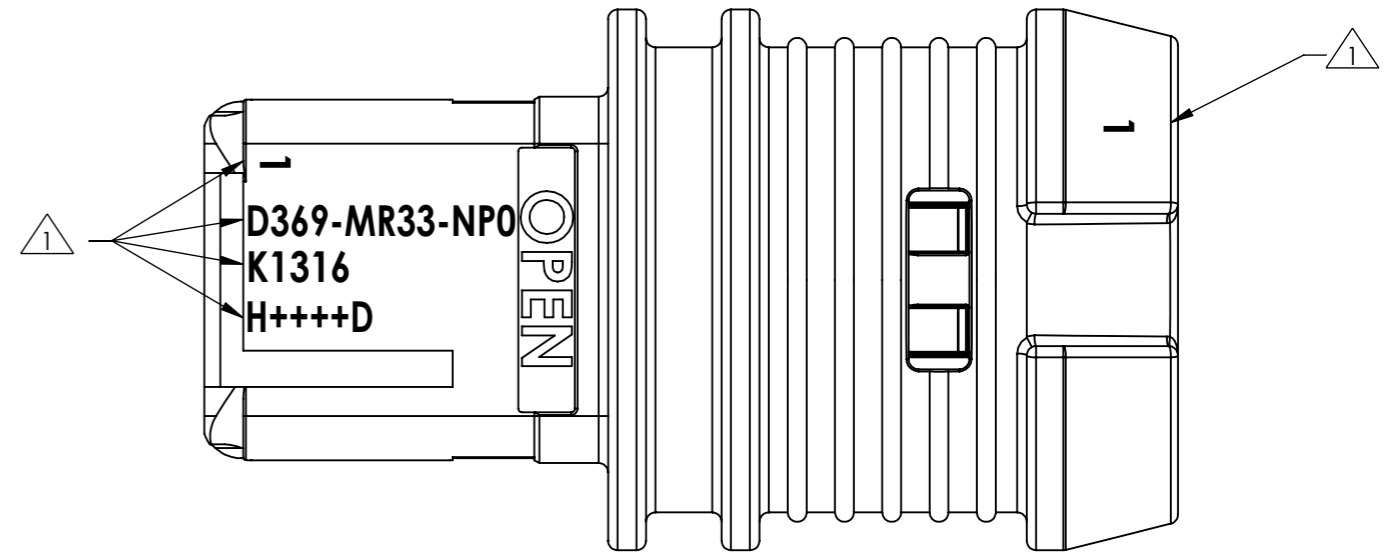

**3 WAY RECEPTACLE (SOCKET/FEMALE CONTACTS)**



**3 WAY RECEPTACLE (PIN/MALE CONTACTS)**

THE CONNECTOR DESCRIBED  
ON THIS DRAWING SHALL  
MEET THE QUALIFICATION  
REQUIREMENTS AS OUTLINED  
IN TE QTP 109-163002

<b>BS8888</b> THIRD ANGLE PROJECTION 	MATERIAL: <b>SEE NOTE 5</b>	FINISH: <b>SEE NOTE 5</b>	 <b>DEUTSCH</b> TE CONNECTIVITY UK LTD., ST. LEONARDS-ON-SEA, TN38 9RF, UK.		
	TITLE: <b>SHIELDED D369 RECEPTACLE SHELL SIZE 3, 3 WAY</b>				TYPE: CUSTOMER DRAWING
UNLESS OTHERWISE STATED: DIMENSIONS: mm [INCHES]	SIZE: <b>A3</b>	SCALE: <b>5:1</b>	DRAWING NUMBER: <b>612082-3-ENV</b>	SHEET: <b>2 OF 2</b>	ISSUE: <b>AG</b>

单击下面可查看定价，库存，交付和生命周期等信息

[>>TE Connectivity\(泰科\)](#)