

LOC		DIST		REVISIONS			
AD	00	REV	DATE	BY	CHK	APPV	
02		REVISED PER ECO-08-009171	22APR08	DH	AS		

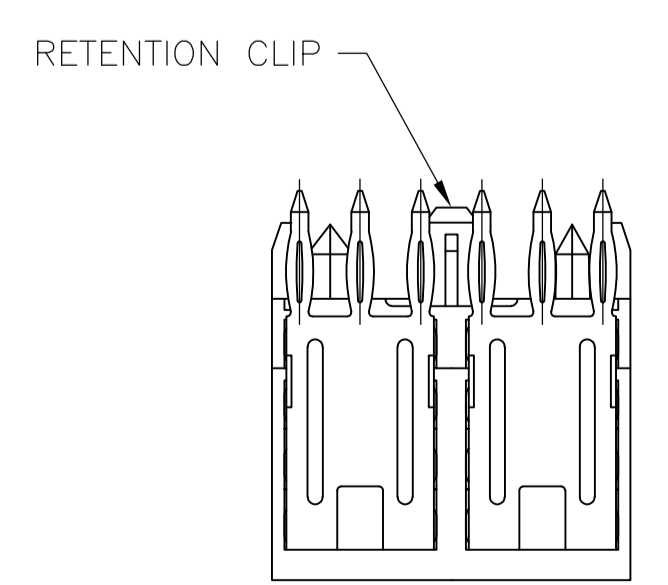

- 1 HOUSING MATERIAL: LIQUID CRYSTAL POLYMER.
- 2 CONTACT MATERIAL: PHOSPHOR-BRONZE.
- 3 CONTACT FINISH:(D)
 UNDERPLATE (ENTIRE CONTACT):
 0.00127 MIN NICKEL PER SAE-AMS-QQ-N-290
 ON MATING SURFACES:
 FLASH GOLD PER ASTM B 488, OVER
 0.00076 MIN PALLADIUM-NICKEL OVER UNDERPLATE, OR
 0.00076 MIN GOLD PER ASTM B 488 OVER UNDERPLATE.
 ON LEADS:
 0.00127 MIN MATTE TIN PER ASTM B 545 OVER UNDERPLATE.
 LUBRICATION (MIN MATING SURFACES):
 SURFACE CONDITIONER AFTER PLATING.

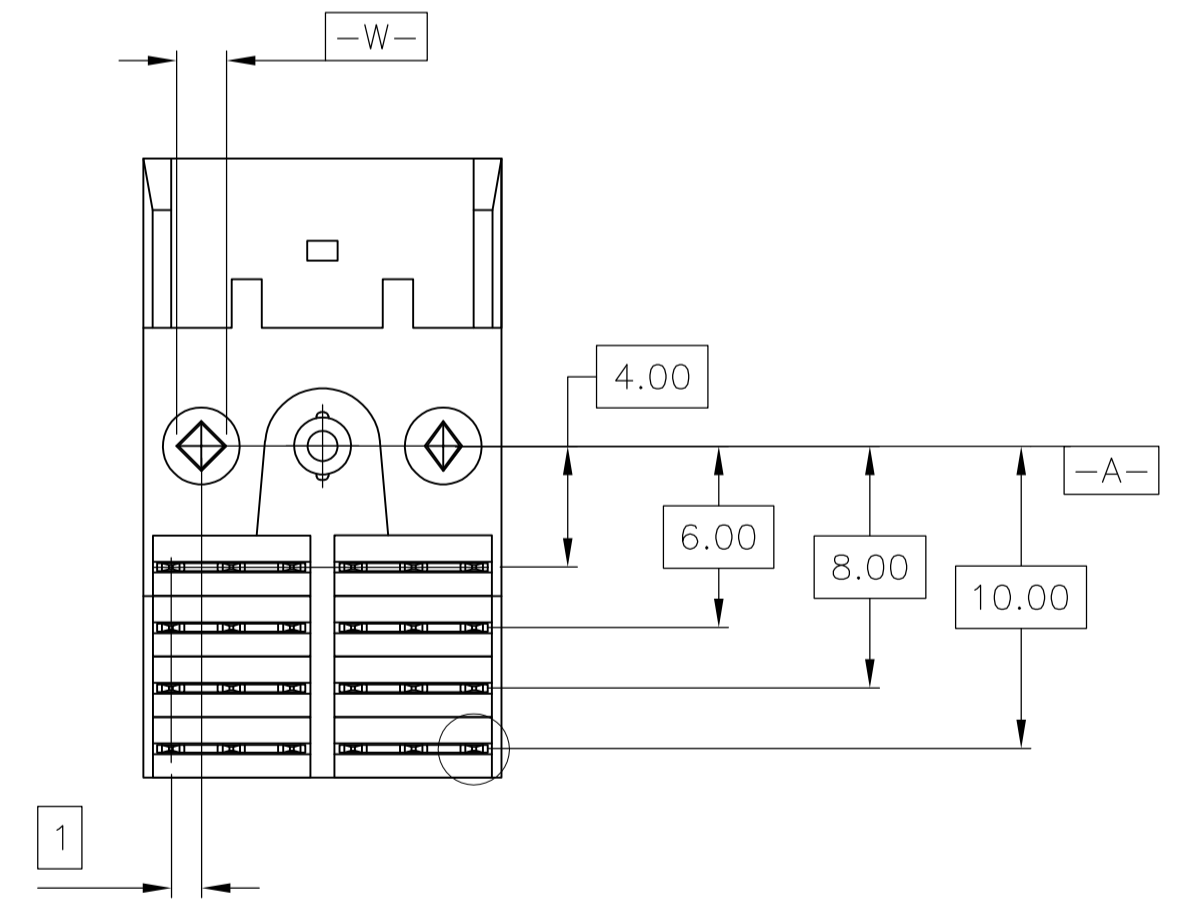
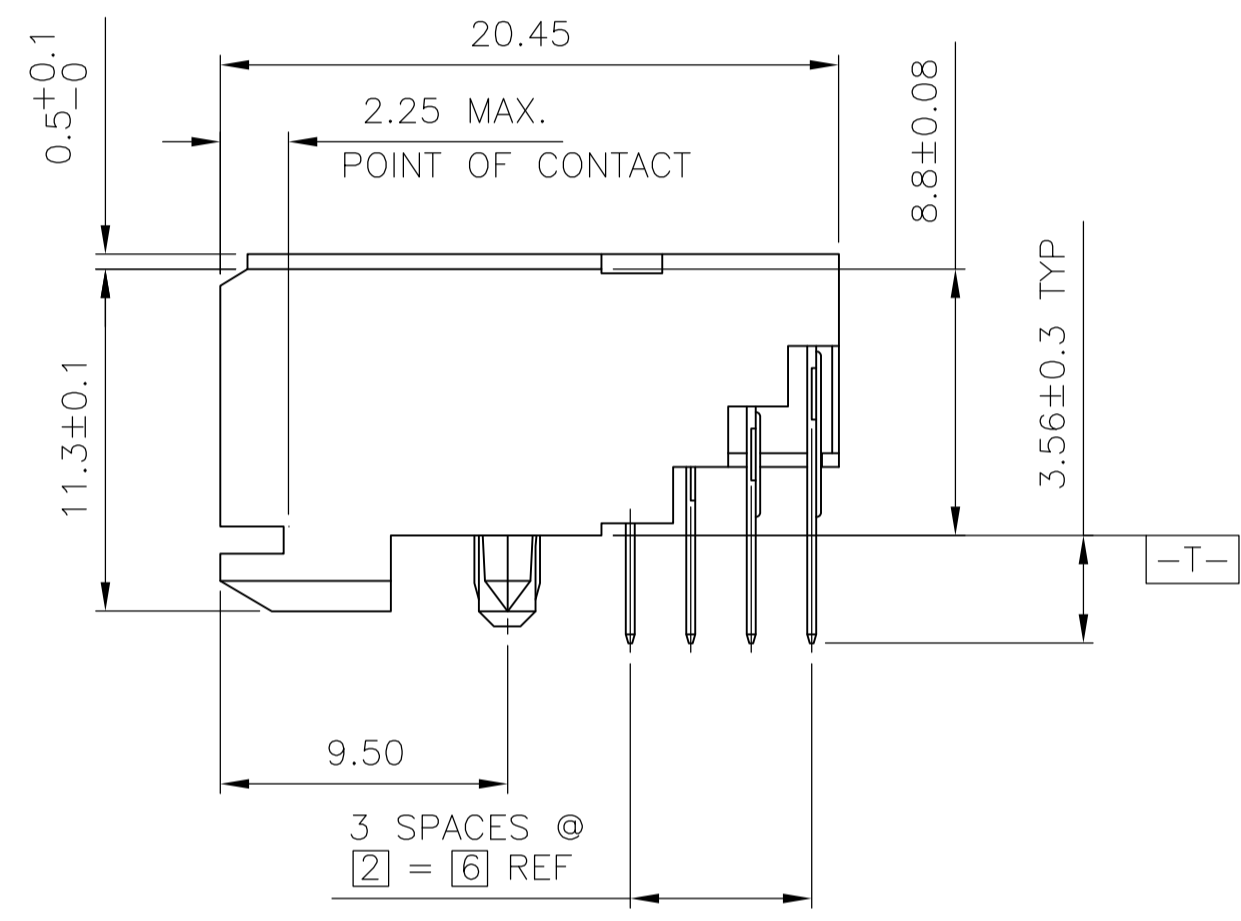
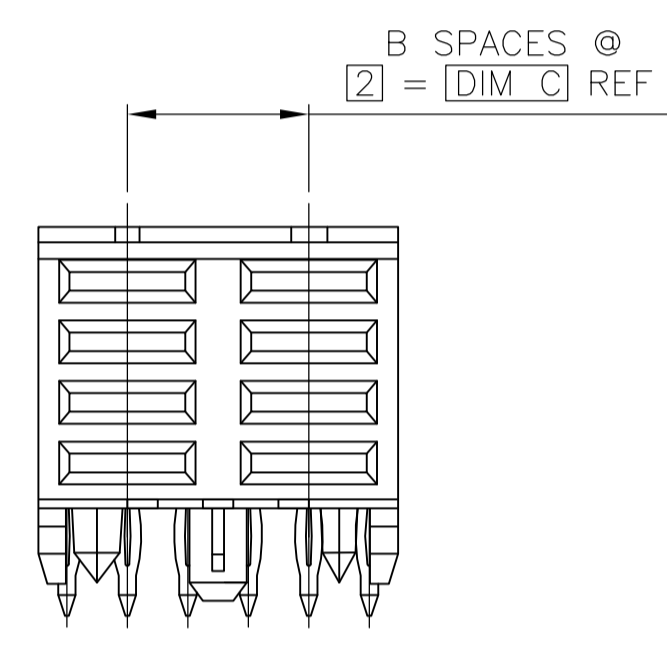
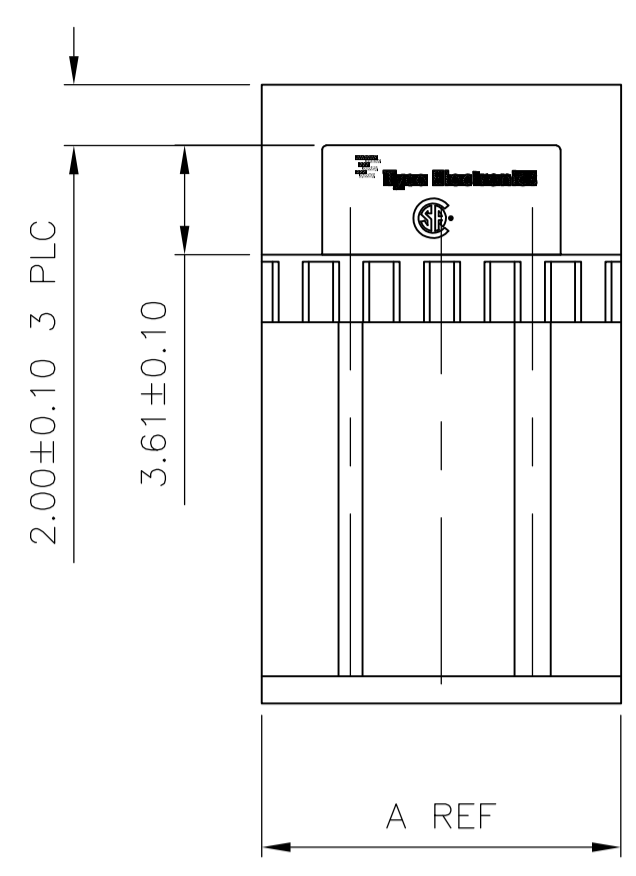
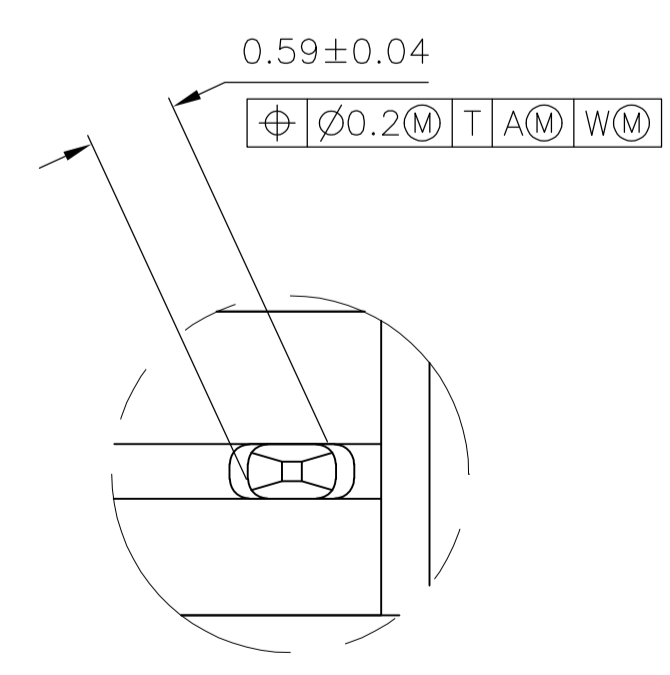
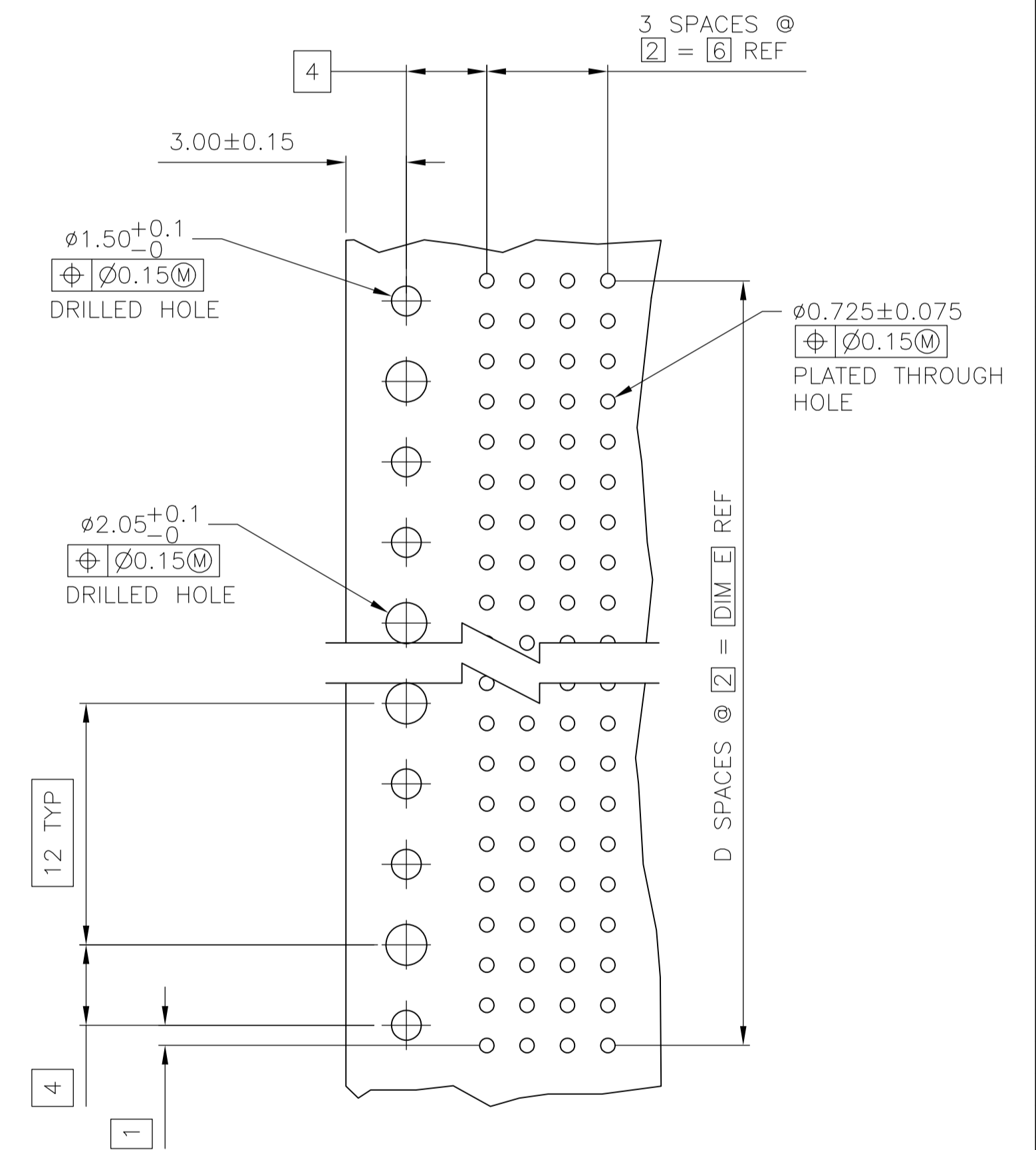

DETAIL Z
SCALE 20:1

RECOMMENDED CIRCUIT PATTERN
PER IPC-D300 TYPE II, CLASS C
(COMPONENT SIDE)

10	5	6	1	11.88	3	8	5536614-1
E	D	C	B	A	FINISH	NO OF POSN	PART NUMBER
THIS DRAWING IS A CONTROLLED DOCUMENT.		DIN D.R.BENDER 11/04/92		S.HAEGER 04/20/93		Tyco Electronics Corporation Harrisburg, PA 17105-3608	
DIMENSIONS: mm		TOLERANCES UNLESS OTHERWISE SPECIFIED:		PRODUCT SPEC		NAME: Z-PACK 2mm FB, POWER MODULE, RCPT. ASSY. 4 ROW, 3.56mm LEAD LENGTH PRESS FIT LEAD	
0 PLC ± -		1 PLC ± -		2 PLC ± 0.13		3 PLC ± -	
4 PLC ± -		ANGLES ± -		APPLICATION SPEC		SIZE: A1 00779 C=5536614	
MATERIAL: 1 2 3		FINISH: 1 2 3		WEIGHT: -		RESTRICTED TO: -	
CUSTOMER DRAWING				SCALE: 4:1		SHEET 1 OF 1 REV 02	

单击下面可查看定价，库存，交付和生命周期等信息

[>>TE Connectivity\(泰科\)](#)