

THIS DRAWING IS UNPUBLISHED. RELEASED FOR PUBLICATION
 © COPYRIGHT BY TYCO ELECTRONICS CORPORATION. ALL RIGHTS RESERVED.

LOC	DIST	REVISIONS			
P	LTR	DESCRIPTION	DATE	DWN	APVD
AG	53	0	RELEASED	26JAN06	JDP JGH
		01	REVISED PER ECO-09-024606	03NOV09	KK AEG

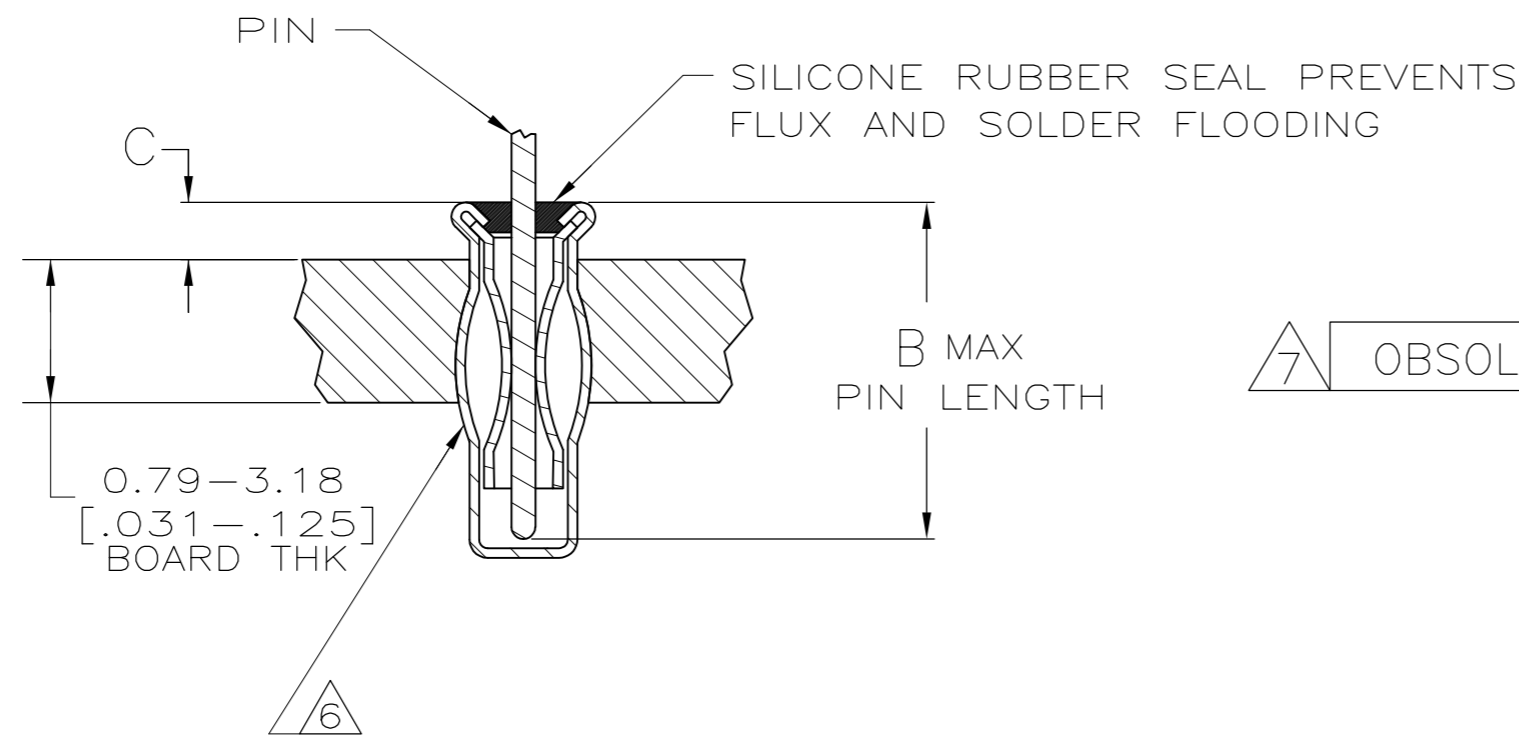
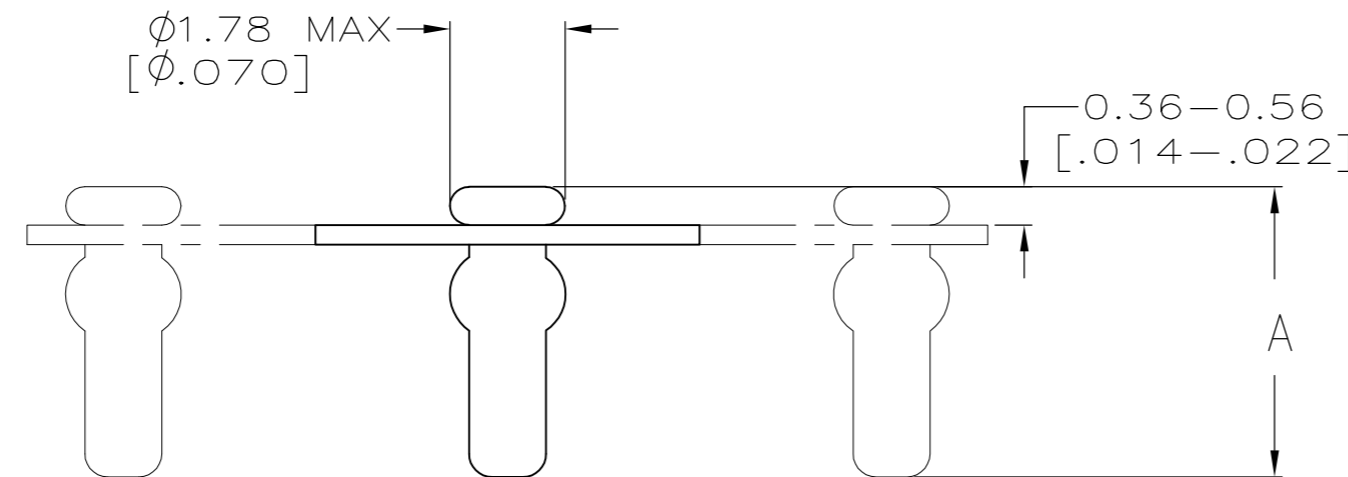
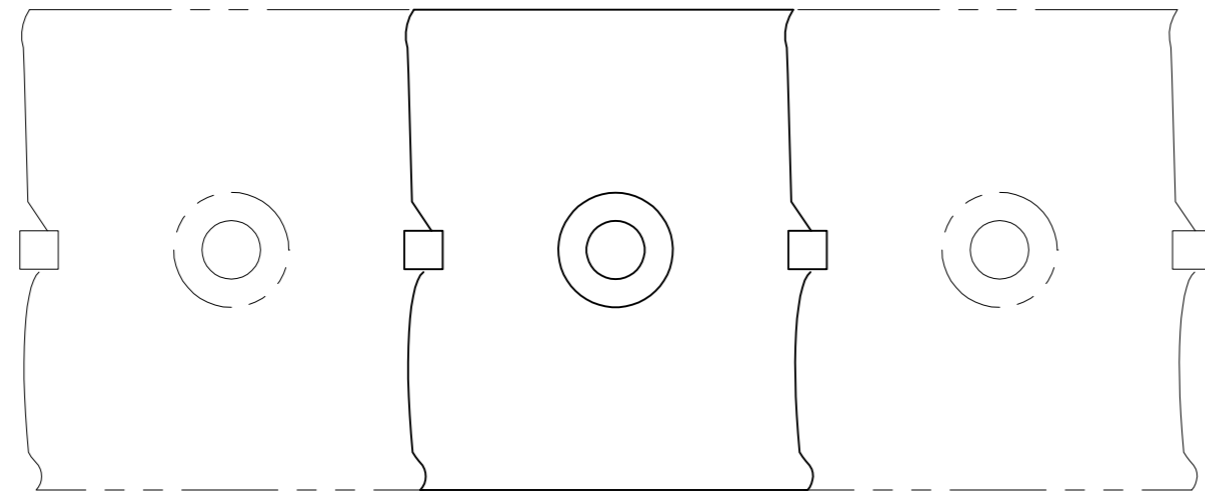

- 1 MATERIAL:
 EYELET- COPPER PER ASTM B 152
 SPRING- BERYLLIUM-COPPER PER ASTM B 194
 SEALANT- SILICONE RUBBER, RTV 738.
- 2 TIN PLATE PER ASTM B 545, 0.00254 [.000100] MINIMUM THICKNESS.
- 3 GOLD PLATE PER ASTM B 488, 0.00076 [.000030] MINIMUM THICKNESS.
- 4. PACKAGE 50,000 PER REEL.
- 5 TO ENSURE 1/2 OZ MIN RETENTION, DO NOT EXCEED 0.05 [.002] DIFFERENCE IN PIN DIA WHEN CHANGING TO A SMALLER DIA PIN.
- 6 PRODUCT IS OVALIZED FOR RETENTION IN THE P.C. BOARD. THE RECOMMENDED HOLE DIAMETER IS Ø1.32 [Ø.052] MINIMUM, +0.08 [.003] MAX. PRIOR TO SOLDERING.
- 7 OBSOLETE PARTS: OBSOLETE CIS STREAMLINING PER D.RENAUD/D.SINISI

7	OBSOLETE	.056-1.14	3.40	3.51	Ø0.56-Ø0.64	3	2	5645899-8-
		[.022-.045]	[.134]	[.138]	[Ø.022-Ø.025]	3	2	5645899-5
		.056-2.54	6.50	6.60	Ø0.46-Ø0.64	SPRING EYELET FINISH		PART NO
		[.022-.100]	[.256]	[.260]	[Ø.018-Ø.025]			

THIS DRAWING IS A CONTROLLED DOCUMENT.		DWN	26JAN06	Tyco Electronics Corporation	
		J. POLIGNONE	26JAN06	Harrisburg, PA 17105-3608	
		CHK	26JAN06		
		J. HAVENER	26JAN06		
		APVD	26JAN06		
		J. HAVENER	26JAN06		
		PRODUCT SPEC	108-14008	MINIATURE SPRING SOCKET ASSY SERIES 2	
		APPLICATION SPEC	114-26004		
		WEIGHT	-	SIZE	A2
		CUSTOMER DRAWING		CAGE CODE	00779
				DRAWING NO	C=5645899
				RESTRICTED TO	-
				SCALE	10:1
				SHEET	1 of 1
				REV	01

单击下面可查看定价，库存，交付和生命周期等信息

[>>TE Connectivity\(泰科\)](#)