

P	LTR	DESCRIPTION	DATE	DWN	APVD

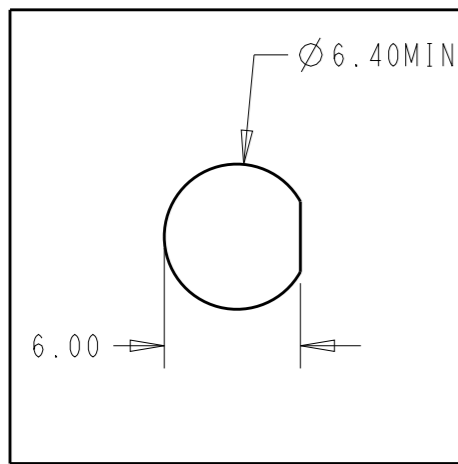

SCALE 3:1
RECOMMENDED PANEL HOLE

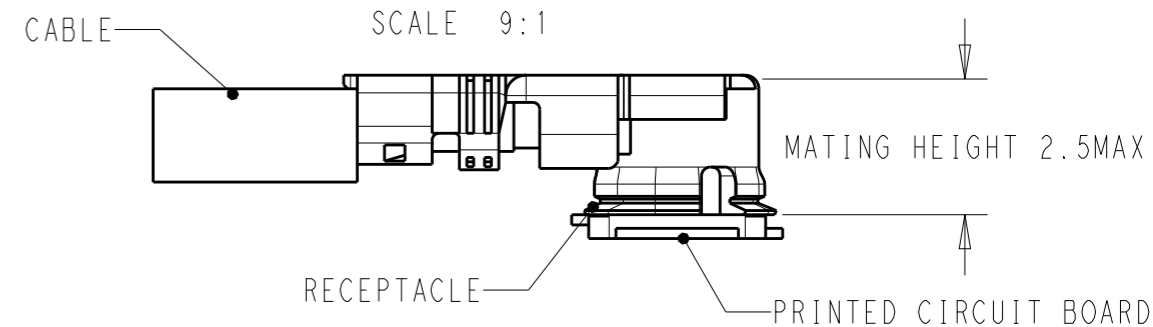

SCALE 3:1

THIS PRINT IS
PRELIMINARY
UNQUALIFIED PRODUCT
CONTACT PRODUCT ENGINEERING
BEFORE USING THIS PRINT

2016693-9	500±5
2016693-8	450±5
2016693-7	350±5
2016693-6	300±3
2016693-5	250±3
2016693-4	200±3
2016693-3	150±3
2016693-2	100±3
2016693-1	50+3
PART NUMBER	LENGTH

- NOTES:
- MATERIAL AND PROCESSING MUST MEET REQUIREMENTS OF TEC-138-702
 - SMA BULKHEAD NEED ASSEMBLY NUT AND WASHER
 - PRODUCT RATING:
TEMPERATURE: -45°C TO +85°C
VOLTAGE: 30V (RMS)
CHARACTERISTIC IMPEDANCE: 50 OHMS Normal
FREQUENCY RANGE: DC TO 6GHz
BEND RADIUS: 5MM MIN
 - CABLE ASSEMBLY TO BE 100% SI TESTED
VSWR:
1.3:1 MAX @ DC~1000MHz
1.5:1 MAX @ 1000~4000MHz
2.0:1 MAX @ 4000~6000MHz
INSERT LOSS: (2.60*LENGTH+0.4)dB MAX @2GHz
LENGTH UNIT IS METER IN THE FORMULA
 - SMA INTERFACE FOLLOW IEC 60169-15
UMCC GEN1 CAN MATE WITH I-PEX MHF1 SERIES AND HIROSE U.FL SERIES

PC	Q'TY	UNIT	DESCRIPTION	ITEM
PC	1		HEAT SHRINK TUBE	3
PC	0.5		RF CA,UMCC GEN1 BOTH END, WITH 1.13CABLE	2
PC	1		RP-SMA BULKHEAD, FOR 1.13 CABLE	1

THIS DRAWING IS A CONTROLLED DOCUMENT.		DWN 20FEB2019 Cedar Liu		
DIMENSIONS: mm		CHK 04MAR2019 Roger Song		
TOLERANCES UNLESS OTHERWISE SPECIFIED: 0 PLC ±- 1 PLC ±0.5 2 PLC ±0.13 3 PLC ±0.013 4 PLC ±0.0001 ANGLES ±-		APVD - Roger Song	NAME RF CA, RP-SMA BULKHEAD TO UMCC GEN1 WITH 1.13 CABLE	
MATERIAL TBD		PRODUCT SPEC -	APPLICATION SPEC -	
FINISH -		WEIGHT -	SIZE A3	CAGE CODE 00779
finish_spec_2		RESTRICTED CUSTOMER	DRAWING NO C-2016693	RESTRICTED TO
		SCALE 1:1	SHEET 1 OF 1	REV 1

单击下面可查看定价，库存，交付和生命周期等信息

[>>TE Connectivity\(泰科\)](#)