

REVISIONS					
P	LTR	DESCRIPTION	DATE	DMN	APVO
H5	REVISED PER	ECO-16-006308	08AUG2016	NK	MM

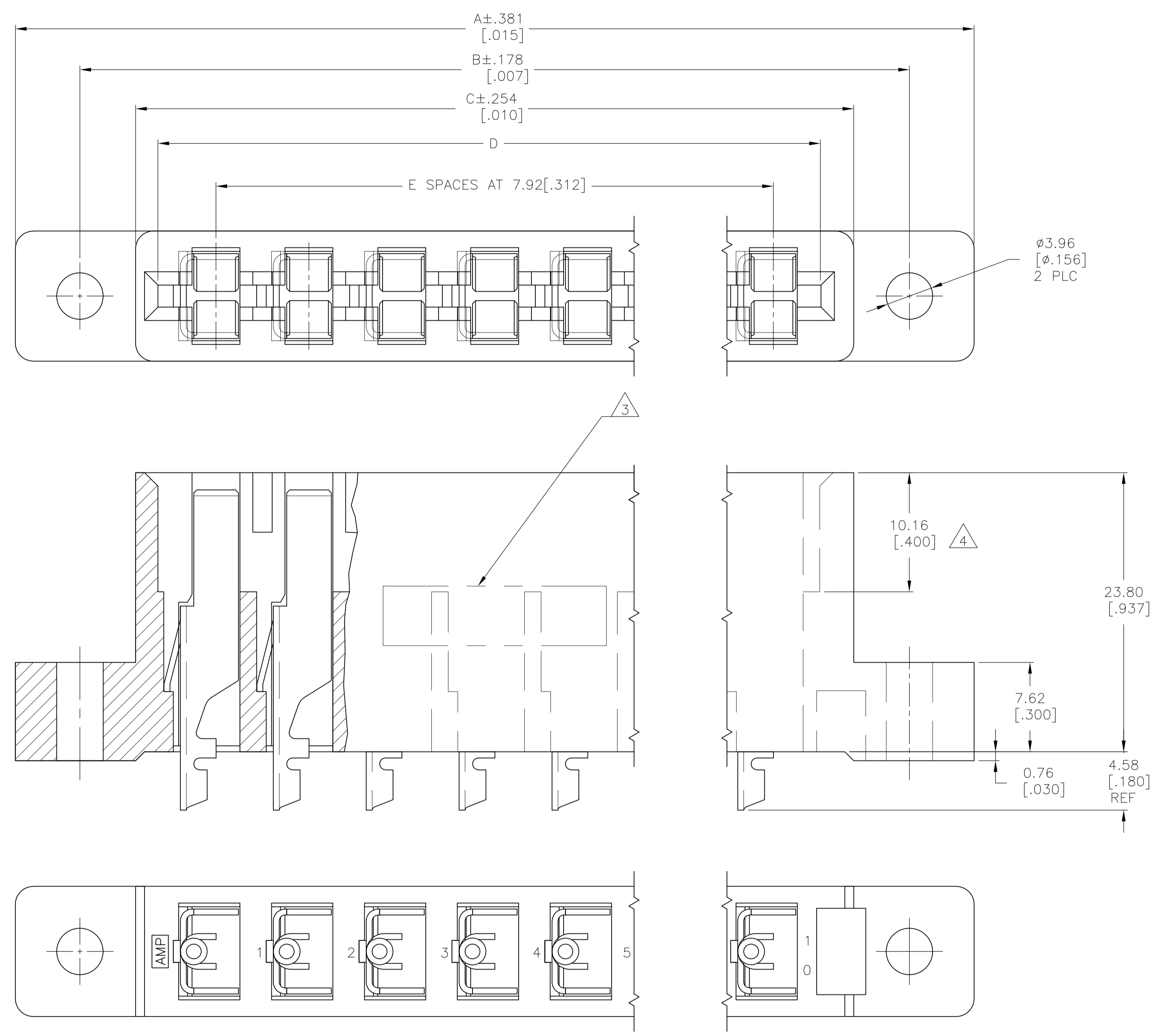

- 1 A 1/16" THICK DUMMY PC BOARD SHOULD BE INSERTED DURING SOLDERING.
- 2 MEASURE ACROSS MOUNTING EARS. MAY GOTO .020 OVER NOMINAL AT TOP OF THE HOUSING.
- 3 AVOID CORING OPTION.
- 4 MATTE TIN PLATED POST.
- 5 OBSOLETE PARTS: OBSOLETE CIS STREAMLINING PER D.RENAUD/D.SINISI

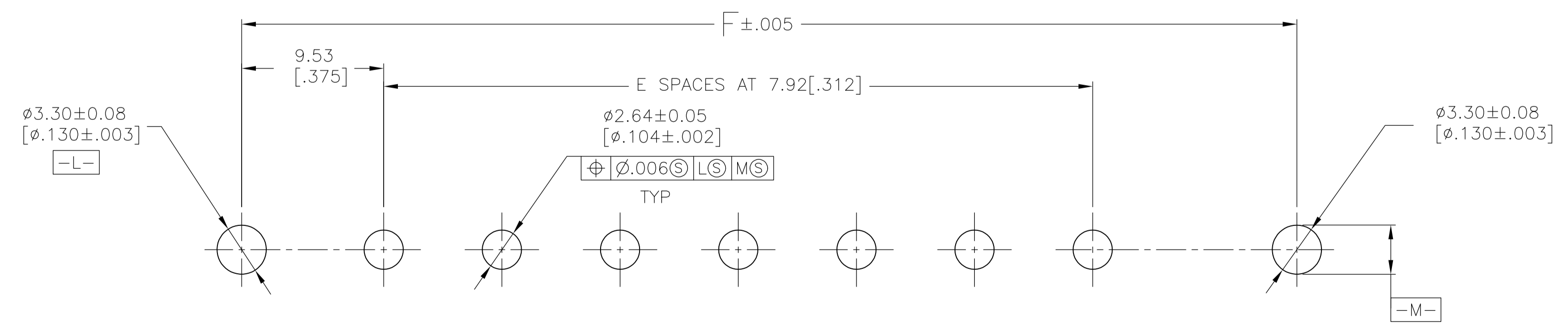
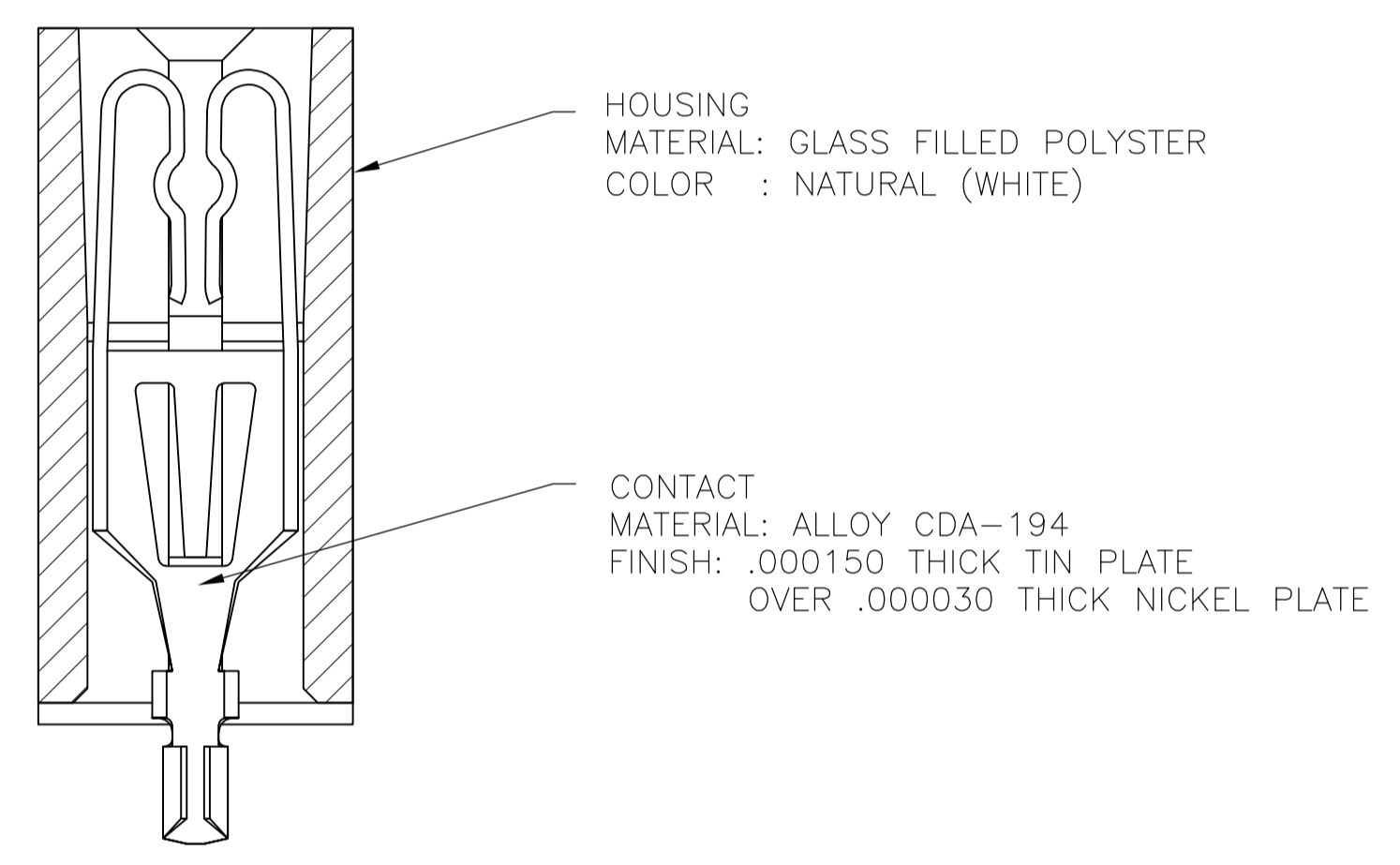

REV	DATE	DESCRIPTION	BY	CHKD	APPD	NO. OF POSN	PART NUMBER	
OBSOLETE	4.346	11	3.832	3.972	4.346	4.780	12	5-531353-9
5	3.722	9	3.208	3.348	3.722	4.156	10	5-531353-8
OBSOLETE	3.410	8	2.896	3.036	3.410	3.844	9	5-531353-7
	3.098	7	2.584	2.724	3.098	3.532	8	5-531353-6
	2.474	5	1.960	2.100	2.474	2.908	6	5-531353-5
5	2.162	4	1.648	1.788	2.162	2.593	5	5-531353-4
	1.850	3	1.336	1.476	1.850	2.284	4	5-531353-3
5	1.538	2	1.024	1.164	1.538	1.972	3	5-531353-2
	1.226	1	0.712	0.852	1.226	1.660	2	5-531353-1
	4.346	11	3.832	3.972	4.346	4.780	12	531353-9
5	3.722	9	3.208	3.348	3.722	4.156	10	531353-8
	3.410	8	2.896	3.036	3.410	3.844	9	531353-7
	3.098	7	2.584	2.724	3.098	3.532	8	531353-6
	2.474	5	1.960	2.100	2.474	2.908	6	531353-5
5	2.162	4	1.648	1.788	2.162	2.593	5	531353-4
	1.850	3	1.336	1.476	1.850	2.284	4	531353-3
5	1.538	2	1.024	1.164	1.538	1.972	3	531353-2
	1.226	1	0.712	0.852	1.226	1.660	2	531353-1
	F	E	D	C	B	A	NO. OF POSN	PART NUMBER

THIS DRAWING IS A CONTROLLED DOCUMENT. DIN R BROWN 230CT94. CMO C MOSHER 230CT94. APVO C MOSHER 230CT94. NAME: CONNECTOR ASSEMBLY, HIGH CURRENT. SIZE: A1. CAGE CODE: 00779. DRAWING NO: 531353. WEIGHT: 0.00779. RESTRICTED TO: CUSTOMER DRAWING. SCALE: 4:1. SHEET: 1 OF 1. REV: H5.

单击下面可查看定价，库存，交付和生命周期等信息

[>>TE Connectivity\(泰科\)](#)