

THIS DRAWING IS UNPUBLISHED. RELEASED FOR PUBLICATION
 © COPYRIGHT - By - ALL RIGHTS RESERVED.

REVISIONS					
P	LTR	DESCRIPTION	DATE	DWN	APVD
	S1	REVISED PER ECN-21-122181	26OCT2021	RZ	WK

1. SEE I.S. 408-1914-1

2 REMOVE FOIL TO OUTER JACKET

3 OBSOLETE PARTS: OBSOLETE CIS STREAMLINING PER D.RENAUD/D.SINISI

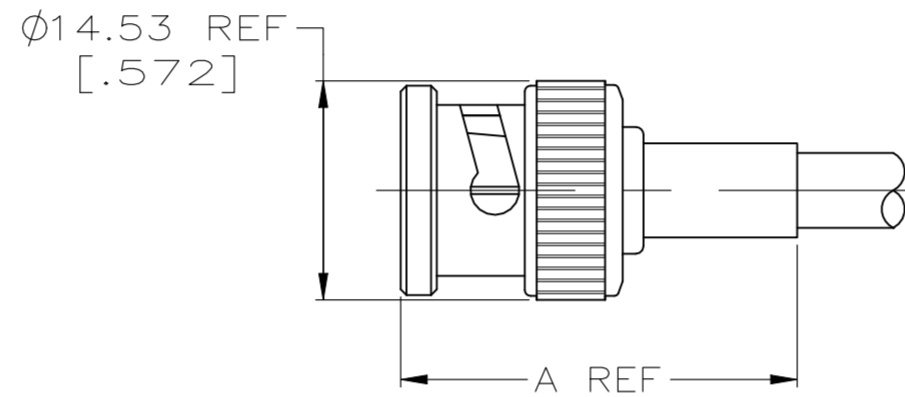
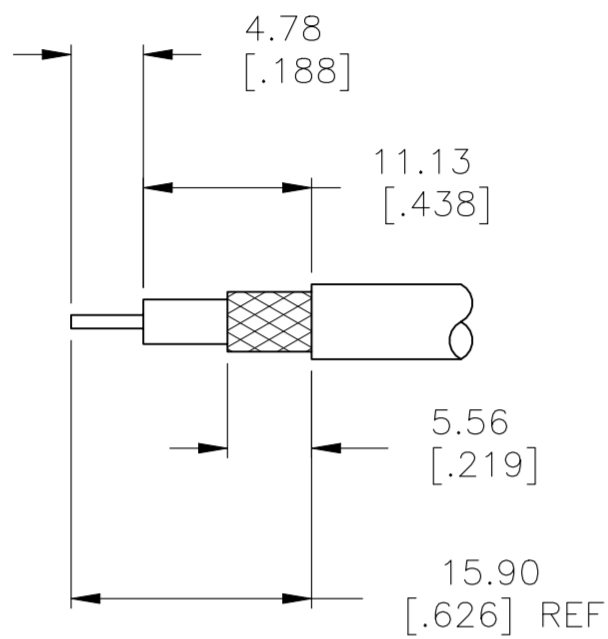

RECOMMENDED STRIP LENGTH

2	RG-188 DOUBLE BRAID	220009-1	30.94 [1.218]	21427-2	9-329049-0	1-331352-2	3-331349-1	5-5225395-6	
	BELDEN 88240, HI-TEMP RG-58/U, BERK-TEK BTDC 58	69478-1	34.14 [1.344]	-	9-228783-0	1-331357-3	2-331349-9	4-5225395-2	
OBSOLETE	HI-TEMP RG-62A/U, TIMES PL62, BELDEN 88241, BERK-TEK BTDC 59 & 62	69477-1	34.14 [1.344]	-	9-228784-0	2-331352-3	3-331349-0	4-5225395-1	
	BELDEN 8212	69477-1	30.94 [1.218]	-	9-50428-0	1-331352-7	3-331349-0	2-5225395-0	
	AMPHENOL 21-597	69477-2	30.94 [1.218]	-	9-329461-0	1-331352-2	3-331349-1	1-5225395-0	
	RG-179/U, 187/U	220009-1	30.94 [1.218]	21427-2	9-328666-0	1-331352-4	3-331349-1	5225395-8	
	RG-174/U, 188/U	220009-1	30.94 [1.218]	21427-2	9-328666-0	1-331352-2	3-331349-1	5225395-7	
	RG-142/U, 142A/U, 142B/U	69478-1	30.94 [1.218]	-	9-329099-0	1-331357-4	2-331349-9	5225395-6	
	RG-141/U & 141A/U	69478-1	30.94 [1.218]	-	9-50427-1	1-331357-4	2-331349-9	5225395-5	
	RG-55/U, 55A/U, 55B/U, 223/U	69478-1	30.94 [1.218]	-	9-329099-0	1-331357-3	2-331349-9	5225395-3	
	RG-59/U, 59A/U, 59B/U, 62/U, 62A/U, 62B/U	69477-1	30.94 [1.218]	-	9-50428-0	2-331352-3	3-331349-0	5225395-2	
	RG-58/U, 58A/U, 58B/U, 58C/U	69478-1	30.94 [1.218]	-	9-50427-1	1-331357-3	2-331349-9	5225395-1	
	FOR USE WITH CABLE	CRIMP TOOL	A	4	SLEEVE QTY=1	3 FERRULE QTY=1	2 CONTACT QTY=1	1 PLUG ASSEMBLY QTY=1	PART NUMBER

THIS DRAWING IS A CONTROLLED DOCUMENT.

DIMENSIONS: mm [INCHES]	TOLERANCES UNLESS OTHERWISE SPECIFIED:	DWN 31JAN2005 A. FERNANDEZ-DOCK5	TE Connectivity
		CHK 31JAN2005 J. HAVENER	
	0 PLC ± - 1 PLC ± - 2 PLC ± 0.041 [016] 3 PLC ± - 4 PLC ± - ANGLES ± -	APVD 31JAN2005 J. LIPPERT	NAME
MATERIAL	FINISH	PRODUCT SPEC 108-12020	PLUG DUAL CRIMP, BNC
		APPLICATION SPEC	SIZE CAGE CODE DRAWING NO RESTRICTED TO
		WEIGHT 0.000000	A2 00779 C=5225395
		CUSTOMER DRAWING	SCALE 2:1 SHEET 1 OF 1 REV S1

单击下面可查看定价，库存，交付和生命周期等信息

[>>TE Connectivity\(泰科\)](#)