

THIS DRAWING IS UNPUBLISHED.

RELEASED FOR PUBLICATION

© COPYRIGHT copyright\_dBVe-

ALL RIGHTS RESERVED.

REVISIONS

P	LTR	DESCRIPTION	DATE	DWN	APVD
	H3	REDRAWN PER ECR-16-010131	13JUL2016	NK	PKS
	U	ECR-18-006177	16MAY2018	GG	TD
	U1	REVISED PER ECR-20-009164	14AUG2020	MK	DH

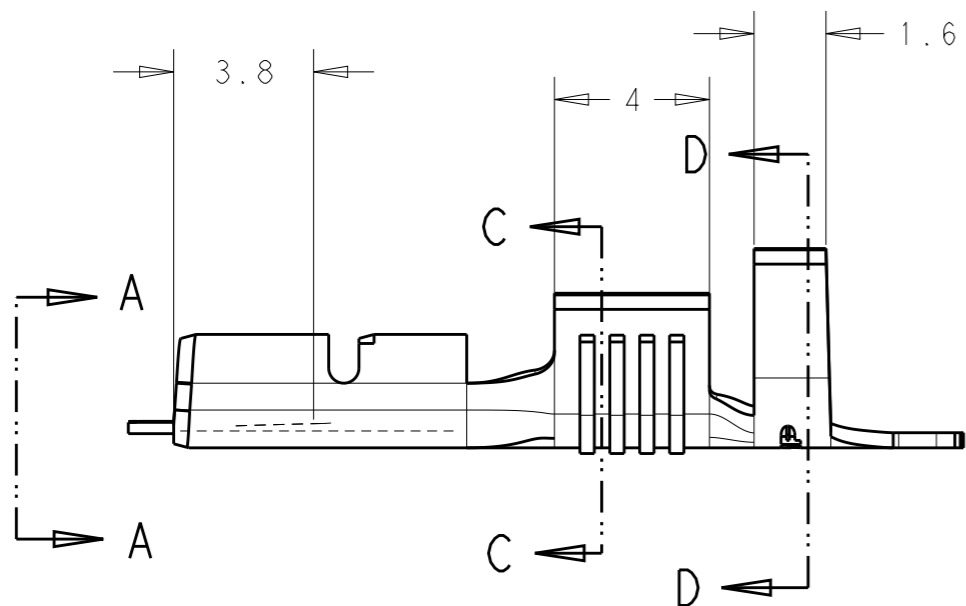

GAP AS REQUIRED TO MEET FORCE SPECIFICATIONS AND 0.71 MAX

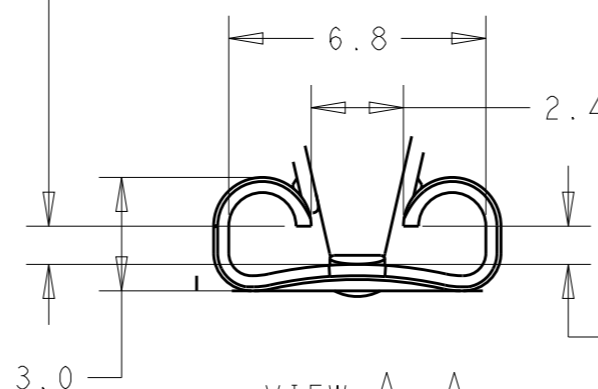

VIEW A-A

1 OBSOLETE PARTS: OBSOLETE CIS STREAMLINING PER D.RENAUD/D.SINISI.

2 MATING TAB THK. IS 0.84-0.76

FOR THICK WITH TONGUE OF 0.8MM HOLE

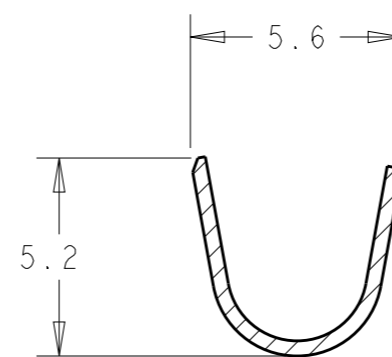

SECTION D-D

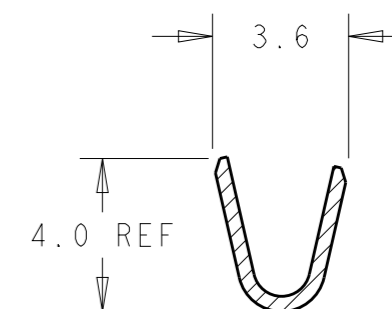

SECTION C-C

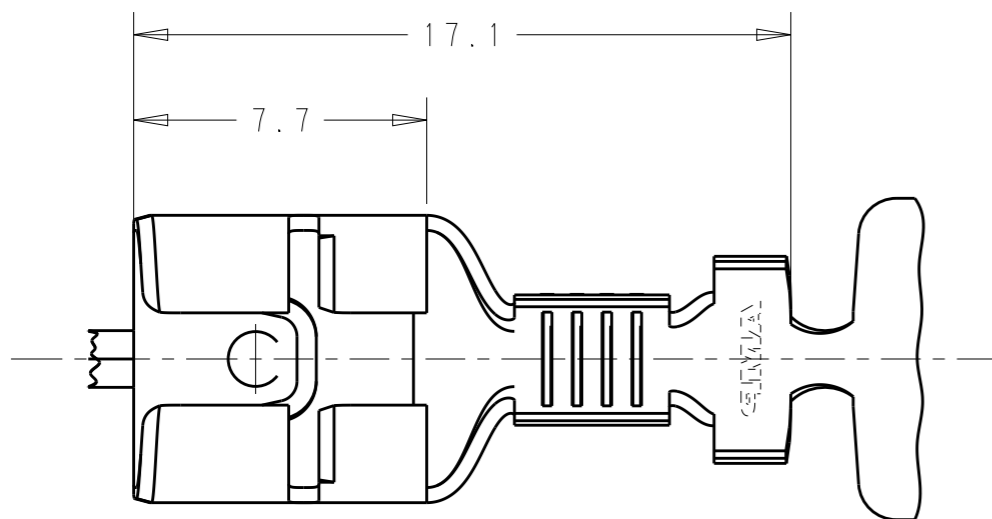

GENERAL TOLERANCE: ±0.4

1	OBSOLETE	NICKEL	STEEL	737440-5
	OBSOLETE	-	BRONZE	737440-4
	OBSOLETE	ARE PRE	LATON	737440-3
		ESTANADO	LATON	737440-2
		-	LATON	737440-1
		FINISH	MATERIAL	PART NO.

WIRE RANGE: 1.0-2.5 MM<sup>2</sup>

INS. RANGE: 03.0-4.3MM

THIS DRAWING IS A CONTROLLED DOCUMENT.

DIMENSIONS: mm

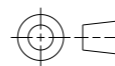

TOLERANCES UNLESS OTHERWISE SPECIFIED:

0 PLC	±-
1 PLC	±-
2 PLC	±-
3 PLC	±-
4 PLC	±-
ANGLES	±-

MATERIAL -

FINISH -

DWN NAGALAKSHMI K 13JUL2016

CHK KRISHNAN P U PRASANTH 13JUL2016

APVD KRISHNAN P U PRASANTH 13JUL2016

PRODUCT SPEC -

APPLICATION SPEC -

WEIGHT -

CUSTOMER DRAWING

NAME RECEPTACULO FASTON 6,35

SIZE A3 CAGE CODE 00779 DRAWING NO G=737440 RESTRICTED TO

SCALE 5:1 SHEET 1 OF 1 REV U1



单击下面可查看定价，库存，交付和生命周期等信息

[>>TE Connectivity\(泰科\)](#)