

THIS DRAWING IS UNPUBLISHED. RELEASED FOR PUBLICATION  
 © COPYRIGHT - By - ALL RIGHTS RESERVED.

LOC		DIST		REVISIONS			
P	LTR	DESCRIPTION		DATE	DWN	APVD	
	D	REV PER ECO 15-017024		11-25-15	CT	WM	

### ASSEMBLED VIEW

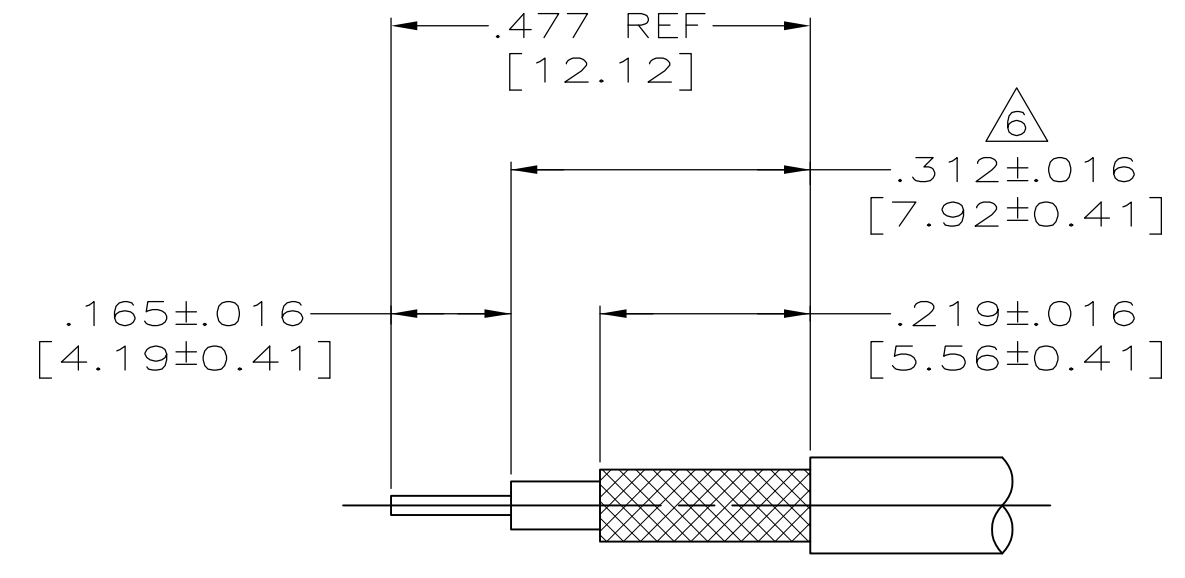
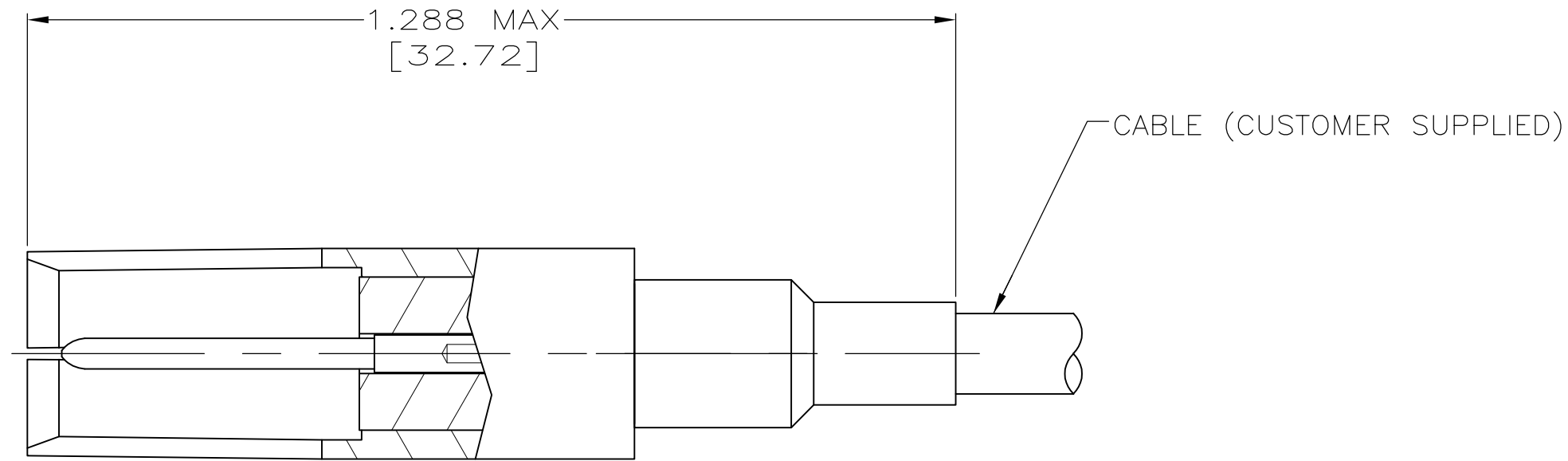

RECOMMENDED STRIP LENGTH  
SCALE: N.T.S.

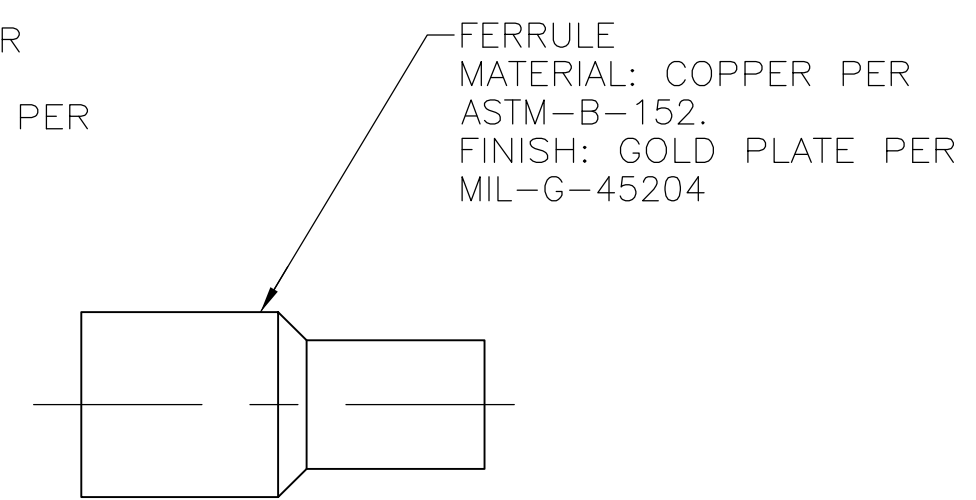
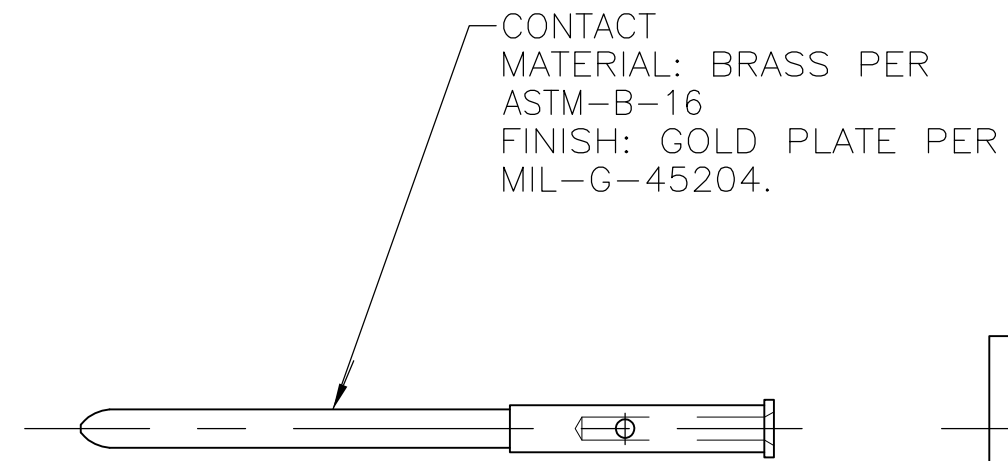
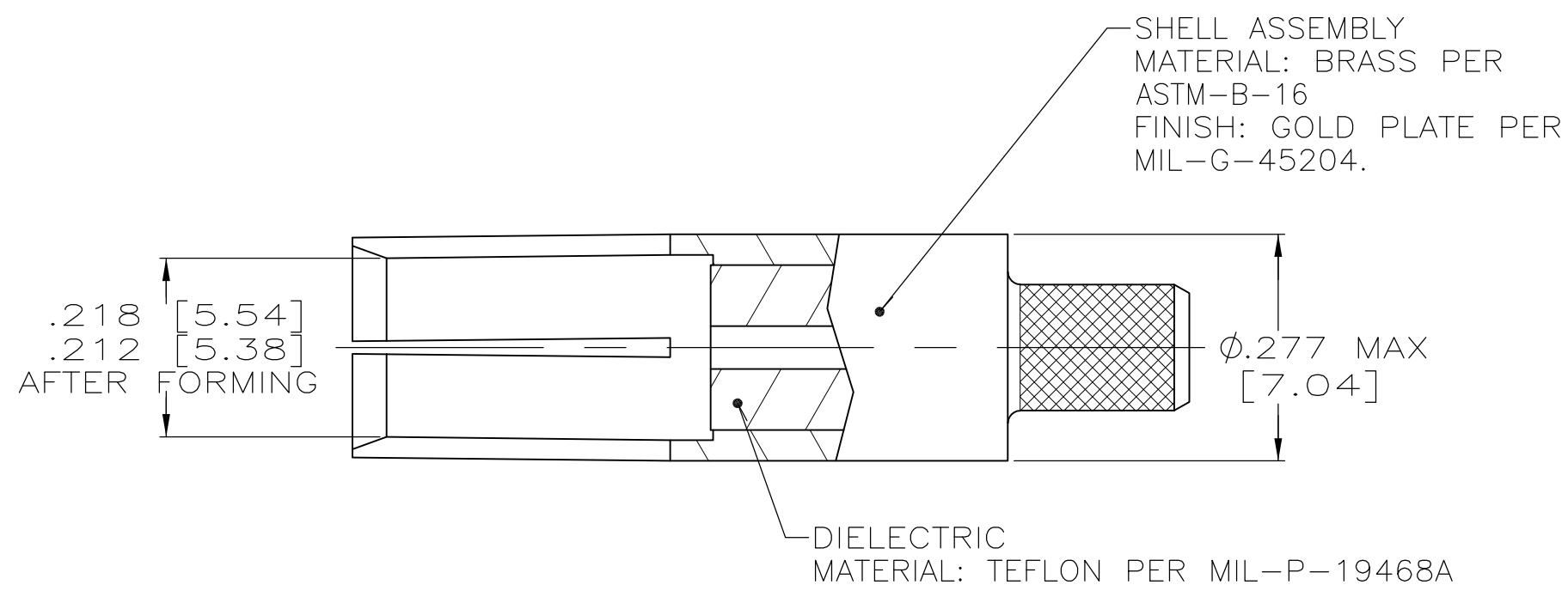

- FOR USE WITH 188A/u & 316/U COAX CABLE.
- FERRULE CRIMPING TOOL: AMP TOOL #220066-1 CRIMP C OR 220066-2 CRIMP C OR 220009-1 CRIMP C.
- CONTACT CRIMPING TOOL: M22520/2-01 OR AMP TOOL NUMBER 1-601966-6, SETTING NUMBER 5. DANIELS POSITIONER PART NO. K345 OR AMP TOOL NO. 1-601966-6.
- SEE I.S.2348.
- DANIELS MANUFACTURING CORP  
2266 FRANKLIN ROAD  
BLOOMFIELD HILLS, MI 48013

△ OUTER JACKET OF CABLE MUST BE TRIMMED TO ALLOW PROPER INTER-PIN CONTACT LOCATION AFTER FERRULE CRIMP OPERATION.

- PARTS SHIPPED UNASSEMBLED AND CABLE IS SUPPLIED BY CUSTOMER.

225791-9  
PART NO.

THIS DRAWING IS A CONTROLLED DOCUMENT.		DWN	C.C.THOMAS	2-1-95	 TE Connectivity
DIMENSIONS: INCHES		CHK	J.DUNBAR	2-2-95	
TOLERANCES UNLESS OTHERWISE SPECIFIED:		APVD	-	-	
0 PLC ± - 1 PLC ± - 2 PLC ± - 3 PLC ± - 4 PLC ± - ANGLES ± -		PRODUCT SPEC	108-12045		
MATERIAL SEE CALLOUTS		FINISH	SEE CALLOUTS		APPLICATION SPEC
		WEIGHT	-		SIZE
		CUSTOMER DRAWING	SCALE	5:1	CAGE CODE
					DRAWING NO
					RESTRICTED TO
					NAME
					CONNECTOR, COAXIAL, RF
					SOCKET SIZE 5, ARINC
					(HEX CRIMP)
					SCALE
					SHEET
					1 of 1
					REV
					D

225791-9

B

A

单击下面可查看定价，库存，交付和生命周期等信息

[>>TE Connectivity\(泰科\)](#)